



NetAXS™

NX4S1

Access Control Unit Installation Guide

Copyright© 2007 Honeywell. All rights reserved.

All product and brand names are the service marks, trademarks, registered trademarks, or registered service marks of their respective owners. Printed in the United States of America. Honeywell reserves the right to change any information in this document at any time without prior notice.

Ordering Information

Please contact your local Honeywell representative or visit us on the web at www.honeywellaccess.com for information about ordering.

Feedback

Honeywell appreciates your comments about this manual. Please visit us on the web at www.honeywellaccess.com to post your comments.

CONTENTS



NetAXS™ NX4S1 Installation

1.0 Notices.....	1
1.1 Warnings and Cautions.....	1
1.2 Product Liability, Mutual Indemnification	2
1.3 Limited Warranty.....	2
1.4 Federal Communications Commission.....	3
1.5 Industry Canada	3
1.6 Underwriters Laboratories Incorporated.....	4
2.0 Introduction.....	5
2.1 Access Control Overview	5
2.2 NetAXS™ Access Overview.....	5
3.0 Panel Components and Descriptions.....	6
3.1 NetAXS™ Access Control Unit	7
Real-Time Clock Protection	7
Memory Protection	7
Reader and AUX Power	7
3.2 Power Supply.....	8
3.3 Battery.....	8
3.4 Enclosure	8
3.5 Suppressors	8
4.0 Installation.....	9
4.1 Cabinet Mounting	10
4.2 Reader Wiring.....	14
4.3 Supervised Input Wiring.....	14
4.4 NX4S1 Control Output Wiring.....	16
4.5 Communications	16
RS-232 Communications	16
RS-485 Communications	18
Ethernet TCP/IP Communications	19
4.6 DIP Switch Settings.....	21
4.7 Jumper Settings.....	23
4.8 Downstream I/O.....	23

5.0 System Configuration.....	26
5.1 RS-485 Connection via PCI-2	26
5.2 RS-485 Connection via NetAXS™	27
5.3 RS-485 Connections with Multidrop Panels at Both Ends of the Cable	28
5.4 RS-232 Connection.....	30
5.5 Ethernet Connection	31
5.6 LANSRLU1 Connection.....	32
5.7 RS-485 Short Haul Modem Connection via PCI-2	33
5.8 RS-485 Short Haul Modem Connection via NetAXS™	34
5.9 RS-232 Short Haul Modem Connection.....	35
5.10 M-56K Dial-up Modem, RS-485 Connection via Hub.....	36
5.11 M-56K Dial-up Modem, RS-485 Connection via NetAXS™.....	37
5.12 Fiber Converter to RS-485 Connection via PCI-2.....	38
5.13 Fiber Converter to RS-485 Connection via NetAXS™.....	39
5.14 N-485-PCI-2/NetAXS™ Access Controller Panel Connection Detail.....	40
5.15 NetAXS™/NetAXS™ Access Controller Panel Connection Detail	41
6.0 NetAXS™ Startup	42
6.1 LED Operation.....	42
7.0 Hardware Specifications	44
7.1 Relay Contacts	44
7.2 Reader Interface.....	44
7.3 NX4S1 Wire Requirements	44
7.4 Maximum Output Loading	44
7.5 Common Connections.....	45
7.6 Mechanical.....	45
7.7 Environment.....	45
7.8 Communications and Wiring	46
7.9 Reader Wiring.....	46
7.10 NX4S1 Wiring Diagram	47
8.0 Maintenance.....	48
9.0 Troubleshooting	48
10.0 Technical Support.....	49
10.1 Normal Support Hours.....	49
10.2 Web.....	49

NetAXS™ Standalone Operation

A.1 Basic Standalone Operations.....	51
A.1.1 Card Read / Door Lock Operation	51
A.1.2 Door Egress / Door Lock / Door Status Operation	51
A.2 Standalone Settings.....	52
A.2.1 NetAXS™ Panel Hardware Settings	52
A.2.2 Communication Settings	52
A.2.3 Emulation Settings	52
A.2.4 Verifying Communications.....	52
A.3 Standalone Commands.....	53
A.3.1 T (Time) Command	53
A.3.2 D (Date) Command.....	54
A.3.3 L (Time Zone) Command	55
A.3.4 C (Card Add) Command	56
A.3.5 C (Card Delete) Command	56
A.3.6 W (Input) Command	57
A.3.7 P (Interlock) Command.....	57
A.3.8 Flow Control Disable/Enable.....	58
A.4 NetAXS™ Panel Defaults	59
A.4.1 Reader Ports	59
A.4.2 Reader LED Outputs	59
A.4.3 Reader Tamper Inputs.....	60
A.4.4 Door Egress Inputs.....	60
A.4.5 Door Status Inputs.....	61
A.4.6 ACFAIL and Panel Tamper Inputs	61
A.4.7 Additional Generic Outputs	62

LIST OF FIGURES

Figure 1: NX4S1 Panel Components	6
Figure 2: NetAXS™ NX4S1 Panel Cabinet, Front View	10
Figure 3: NetAXS™ NX4S1 Panel Cabinet, Top View	11
Figure 4: NetAXS™ NX4S1 Panel Cabinet, Bottom View	11
Figure 5: NetAXS™ Panel Cabinet, Left View	12
Figure 6: NetAXS™ NX4S1 Panel Cabinet, Right View	13
Figure 7: Typical Supervised Input Wiring Diagram	15
Figure 8: RJ-45 Serial Port	17
Figure 9: RS-232 Configuration	17
Figure 10: RS-485 Configuration via N-485-PCI-2 or PCI-3	18
Figure 11: RS-485 Configuration via NetAXS™ Gateway	19
Figure 12: Ethernet TCP/IP Configuration	19
Figure 13: Ethernet MAC Address Location	20
Figure 14: DIP Switch and Jumper Locations	21
Figure 15: Default Downstream I/O Configuration with Wiring	25
Figure 16: RS-485 Connection via PCI-2	26
Figure 17: RS-485 Connection via NetAXS™	27
Figure 18: RS-485 Connection via NetAXS™ with Multidrop Panels at Both Ends	28
Figure 19: RS-485 Connection via PCI-2 with Multidrop Panels at Both Ends	29
Figure 20: RS-232 Connection	30
Figure 21: Ethernet Connection	31
Figure 22: LANSRLU1 Connection	32
Figure 23: RS-485 Short Haul Modem Connection via PCI-2	33
Figure 24: RS-485 Short Haul Modem Connection via NetAXS™	34
Figure 25: RS-232 Short Haul Modem Connection	35
Figure 26: M-56K Dial-up Modem, RS-485 Connection via Hub	36
Figure 27: M-56K Dial-up Modem, RS-485 Connection via NetAXS™	37
Figure 28: Fiber Converter to RS-485 Connection via PCI-2	38
Figure 29: Fiber Converter to RS-485 Connection via NetAXS™	39
Figure 30: N-485-PCI-2/NetAXS™ Access Controller Panel Connection Detail	40
Figure 31: NetAXS™/NetAXS™ Access Controller Panel Connection Detail	41
Figure 32: System, Relay and Power LEDs	42
Figure 33: NX4S1 Panel Wiring Diagram	47

LIST OF TABLES



Table 1	Reader Wiring	14
Table 2	Default Supervised Input Assignments	14
Table 3	DIP Switch Settings	22
Table 4	MIRO 32/0 DIP Switch and Jumper Settings	23
Table 5	LED Status	43
Table 6	Communications and Wiring	46
Table 7	Reader Wiring	46
Table 8	Troubleshooting Problems and Solutions	48

NetAXS™ NX4S1 Installation

1.0 Notices

1.1 Warnings and Cautions



Warning: Fire Safety and Liability Notice: Never connect card readers to any critical entry, exit door, barrier, elevator or gate without providing an alternative exit in accordance with all fire and life safety codes pertinent to the installation. These fire and safety codes vary from city to city and you must get approval from local fire officials whenever using an electronic product to control a door or other barrier. Use of egress buttons, for example, may be illegal in some cities. In most applications, single action exit without prior knowledge of what to do is a life safety requirement. Always make certain that any required approvals are obtained in writing. Verbal approvals are not valid.

Warning: Honeywell Access Systems (HAS) never recommends using WIN-PAK or related products for use as a primary warning or monitoring system. Primary warning or monitoring systems should always meet local fire and safety code requirements. The installer must also test the system on a regular basis by instructing the end user in appropriate daily testing procedures. Failure to test a system regularly could make installer liable for damages to the end user if a problem occurs.

Warning: Earth ground all enclosures for proper installation.

Warning: Use suppressors on all door locks. Use HAS (part number S-4) suppressors for installation. Honeywell recommends only DC locks.

Warning: Personal injury or death could occur, and the equipment could be damaged beyond repair, if this precaution is not observed!

- Before installation, turn off the external circuit breaker which supplies power to the system, including door locks.
- Before connecting the device to the power supply, verify that the output voltage is within specifications of the power supply.
- Do not apply power to the system until after the installation has been completed.



Caution: If any damage to the shipment is noticed, a claim must be filed with the commercial carrier responsible.

Caution: Electro-static discharge (ESD) can damage CMOS integrated circuits and modules. To prevent damage always follow these procedures:

- Use static shield packaging and containers to transport all electronic components, including completed reader assemblies.
- Handle all ESD sensitive components at an approved static controlled workstation. These workstations consist of a desk mat, floor mat and an ESD wrist strap. Workstations are available from various vendors.

1.2 Product Liability, Mutual Indemnification

In the event that a Customer receives a claim that a Product or any component thereof has caused personal injury or damage to property of others, the Customer shall immediately notify Honeywell in writing of all such claims. Honeywell shall defend or settle such claims and shall indemnify and hold the Customer harmless for any costs or damages including reasonable attorneys' fees which the Customer may be required to pay as a result of the defective Product or the negligence of Honeywell, its agents or its employees.

The Customer shall hold harmless and indemnify Honeywell from and against all claims, demands, losses and liability arising out of damage to property or injury to persons occasioned by or in connection with the acts or omissions of the Customer and its agents and employees, and from and against all claims, demands, losses and liability for costs of fees, including reasonable attorneys' fees in connection therewith.

1.3 Limited Warranty

All Products sold or licensed by Honeywell Access Systems (HAS) include a warranty registration card which must be completed and returned to Honeywell by or on behalf of the end user in order for Honeywell to provide warranty service, repair, credit or exchange. All warranty work shall be handled through the Customer which shall notify Honeywell and apply for a Return Merchandise Authorization (RMA) number prior to returning any Product for service, repair, credit or exchange.

Honeywell warrants that its Products shall be free from defects in materials and workmanship for a period of one year from date of shipment of the Product to the Customer. The warranty on Terminals, Printers, Communications Products and Upgrade kits is 90 days from date of shipment. Satisfaction of this warranty shall be limited to repair or replacement of Products which are defective or defective under normal use.

Honeywell's warranty shall not extend to any Product which, upon examination, is determined to be defective as a result of misuse, improper storage, incorrect installation, operation or maintenance, alteration, modification, accident or unusual deterioration of the Product due to physical environments in excess of the limits set forth in Product manuals.

THERE ARE NO WARRANTIES THAT EXTEND BEYOND THIS PROVISION. THIS WARRANTY IS IN LIEU OF ALL OTHER WARRANTIES WHETHER EXPRESS, IMPLIED OR STATUTORY, INCLUDING IMPLIED WARRANTIES OF MERCHANTABILITY OR FITNESS FOR ANY PARTICULAR PURPOSE. NO REPRESENTATION OR WARRANTY OF THE DISTRIBUTOR SHALL EXTEND THE LIABILITY OR RESPONSIBILITY OF THE MANUFACTURER BEYOND THE TERMS OF THIS PROVISION. IN NO EVENT SHALL HONEYWELL BE LIABLE FOR ANY RE-PROCUREMENT COSTS, LOSS OF PROFITS, LOSS OF USE, INCIDENTAL, CONSEQUENTIAL OR SPECIAL DAMAGES TO ANY PERSON RESULTING FROM THE USE OF HONEYWELL PRODUCTS.

1.4 Federal Communications Commission

This equipment has been tested and found to comply with the limits for a Class B digital device, pursuant to part 15 of the FCC Rules. These limits are designed to provide reasonable protection against harmful interference in a residential installation. This equipment generates, uses, and can radiate radio frequency energy, and if not installed and used in accordance with the instructions, may cause harmful interference to radio communications. However, there is no guarantee that interference will not occur in a particular installation. If this equipment does cause harmful interference to radio or television reception, which can be determined by turning the equipment off and on, the user is encouraged to try to correct the interference by one or more of the following measures:

- Re-orient or re-locate the receiving antenna.
- Increase the separation between the equipment and receiver.
- Connect the equipment into an outlet on a circuit different from that to which the receiver is connected.
- Consult the dealer or an experienced radio/TV technician for help.

The user shall not make any changes or modifications to the equipment unless authorized by the Installation Instructions or User's Manual. Unauthorized changes or modifications could void the user's authority to operate the equipment.

For panels using the Ethernet connection, the cable clamp (HAS part number 3-000342) must be used for the panel to pass the FCC Part 15 Class B requirements. See "[Installation](#)" on page 9 for clamp installation instructions.

1.5 Industry Canada

This Class B digital apparatus meets all requirements of the Canadian Interference-Causing Equipment Regulations.

Cet appareil numérique de la classe B respecte toutes les exigences du Règlement sur le matériel brouilleur du Canada.

1.6 Underwriters Laboratories Incorporated

The NetAXS™ panel was reviewed by Underwriters Laboratories Incorporated for Access Control System Units - Category ALVY, UL294 standard. The NetAXS™ panel was reviewed as a stand alone system. The input points only monitor the door position. The NetAXS™ panel is not intended as a Proprietary Alarm Unit - Category APOU, UL1076 standard.

The NetAXS™ panel was reviewed using the following Honeywell readers: OmniAssure (TM) OT30, OmniClass (TM) OM40 and OM55, and OmniProx (TM) OP30 and OP40.



Notes:

- All field wiring, except the battery backup/charger wiring, is Class 2 power-limited.
- UL has not evaluated communication with panels that are not NetAXS™ panels.
- Underwriters Laboratories (UL) has reviewed only the configurations shown in “[RS-485 Connection via PCI-2](#)“ on page 26, “[RS-485 Connection via NetAXS™](#)“ on page 27, and “[RS-232 Connection](#)“ on page 30 of this guide. Because UL has reviewed the NetAXS™ panel only as a standalone system, the computer terminal, NetAXS™ gateway panel, and N-485_PCI-2 adapter appear in these sections only to illustrate the installation and programming of the NetAXS™ panel.
- UL has not evaluated the compatibility of downstream I/O devices (see “[Downstream I/O](#)“ on page 23) with the NetAXS™ panel.

2.0 Introduction

2.1 Access Control Overview

An access control system protects and preserves an enterprise's resources by providing authentication, authorization, and administration services. Authentication is a process that verifies a user's identity. If the user is verified, the system then either grants or denies access to specific areas and resources. Administration includes the creation and modification of user accounts and access privileges.

An access control system consists of hardware and software, usually configured in a network environment over a standard network protocol. Access control units, readers, door strikes, and video and other devices, for example, are configured to control and monitor the access to a company site.

2.2 NetAXS™ Access Overview

A NetAXS™ access control system consists of a host system and NetAXS™ access control units that meet existing N-1000-III/IV specifications and that communicate with each other and with a variety of input and output devices over the RS-232 and RS-485 network protocols. See "[System Configuration](#)" on page 26 to view illustrations of the supported NetAXS™ system configurations. A NetAXS™ access control system is configured and maintained via either the host system or a web server using RS-232, RS-485, or Ethernet network protocols.

This document describes how to install and configure the NX4L1 access control unit.

3.0 Panel Components and Descriptions

The NX4S1 access control unit consists of a NetAXS™ panel control board and battery. The components are enclosed in a pre-wired cabinet. The 16.5 VAC power supply (Basler Electric Model BE156250CAA0004, M&G Electronics Model MGT1650, or Honeywell Access Systems part number X-4) provides power for the panel control board, which is a four-reader panel providing access control for up to four doors. The following figure shows the NX4S1 panel components.

Figure 1: NX4S1 Panel Components

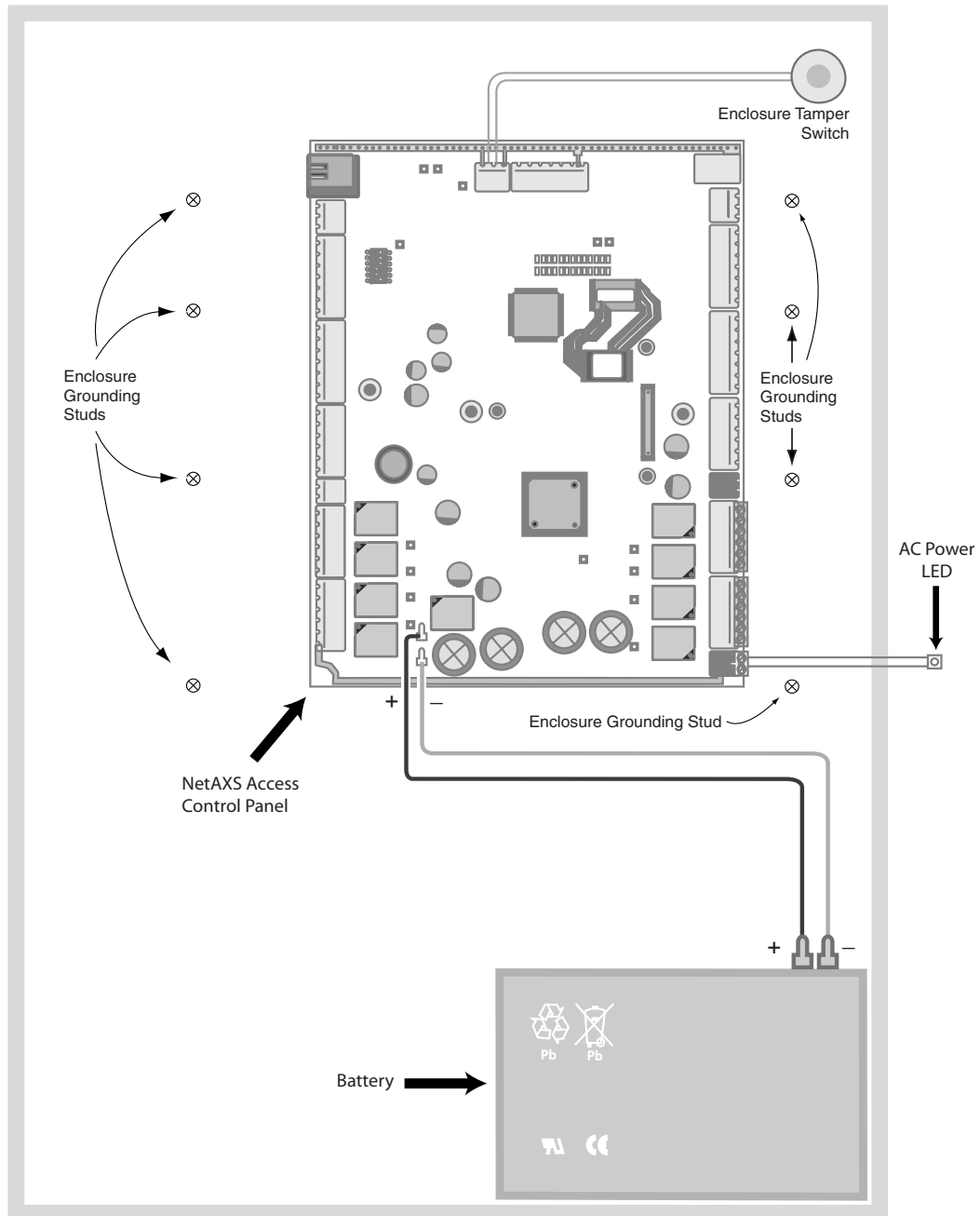



Note: Maintain at least a .25-inch distance between the non-power limited wiring (battery backup/charger wiring) and all other wiring, which is power-limited Class 2 wiring.

3.1 NetAXS™ Access Control Unit

The NetAXS™ panel is a four-reader board that controls up to four doors by providing up to 14 inputs and 8 outputs. The NetAXS™ panel may be used as a stand-alone panel with independent card and transaction storage or, with a host software upgrade, as a fully monitored online access control device. The NetAXS™ panel also supports up to 30 downstream panels in a variety of network configurations. See [Communications](#), page 16, for descriptions and illustrations.

Fourteen inputs are capable of four state supervision: Normal, Alarm, Short and Open. Eight inputs are used as door control with one input used for request to exit on each door and one input used for door status on each door. Supervised inputs for Tamper, External Power Fail and four Reader Tamperers are supplied as well, and they can be used as additional inputs when not required for their default purpose.



Caution: The NetAXS™ board must not be used to power locks. Only through the relay board can the common power supply be used for the NetAXS™ and locking devices.

Real-Time Clock Protection

The panel RTC is backed up using a super capacitor. The super capacitor will power the real-time clock for one week in the absence of primary power or backup battery.

Memory Protection

The NetAXS™ panel continuously saves database and event information in non-volatile FLASH memory. This activity prevents the panel from losing data when power is lost.

Reader and AUX Power

Reader power is supplied within the range of 11.2 VDC and 12.4 VDC with a maximum current of 600 mA. AUX power is supplied within the range of 10.5 VDC and 12.4 VDC with a maximum current of 500mA. The current can be distributed throughout the Reader Power or AUX Power in any configuration as long as the maximum draw is less than 600 mA: Reader 1 + Reader 2 + Reader 3 + Reader 4 + AUX Power < 600 mA.



Caution: AUX Power must not be used to power locks.

For NetAXS™ maximum current draw, refer to [Hardware Specifications](#), page 44.

3.2 Power Supply

The NetAXS™ panel is capable of operating on AC or DC input power. UL has not reviewed the use of a DC power supply with the NX4S1 panel. The AC input must be supplied at 16.5 VAC utilizing one of the following UL-listed, 50 VA, Class 2 transformers: Basler Electric Model BE156250CAA0004, M&G Electronics Model MGT1650 (Honeywell Access Systems part number X-4). Use a two-wire, 18 AWG shielded cable to run the AC power from the wall transformer to the enclosure. The AC voltage is non-polarized and connects to TB17-1 and TB17-2.

A power-on LED assembly is supplied with the NX4S1. It is required by UL to be mounted for external viewing. Refer to [Installation](#), page 9 for details. When there is sufficient AC power, the power-on LED illuminates. If the AC power is off, the LED is not illuminated.

DC power is also non-polarized. The panel uses 24 VDC at 1.5 Amp wired into TB17-1 and TB17-2.

The panel includes an input power indicator that illuminates when input voltage is present. If the indicator is not illuminated, the input voltage is either off or too low to operate the system.



Caution: De-energize the unit before servicing it.

3.3 Battery

One CASIL CA1270 12 VDC, 7 A-Hr sealed lead-acid battery (HAS part number 3-000066) provides standby backup power. When the primary power is off, the NetAXS™ panel automatically switches to the battery for continuous operation. The battery provides three hours of standby backup power.

The NetAXS™ panel is capable of providing 300 mA at 13.7 VDC for battery charging. The panel has deep discharge protection built in for the protection of the battery. If the battery discharges below 10.4 V, the panel disconnects the battery and ceases operation.

Replace the battery every two to two-and-a-half years, or more often if the panel has a high rate of backup use.

Refer to [Installation](#), page 9 for battery cable connection information.

3.4 Enclosure

The NX4S1 enclosure ships pre-wired. Its width is 14.5 inches (368.3 mm), its height is 18.0 inches (457.2 mm), and its depth is 4.4 inches (111.8 mm). The equipped enclosure, including the 7 A-Hr battery, is 22.1 pounds (10 Kg).

3.5 Suppressors

Two suppressors (HAS part number S-4) are required for each door lock. One suppressor is installed on the panel control board, and the second must be installed at the door lock.

4.0 Installation



Perform the following steps to install the NX4S1 panel:

Warning: Use a static strap whenever touching the panel to ensure protection from Electrostatic Discharge (ESD).

1. Review the panel layout, cable runs, and power needs.
2. Mount the enclosure at the proper location on the wall. Use appropriate anchors for the mounting material.
3. Run all I/O wires to the enclosure, and properly mark each wire for its use.
4. Run appropriate length of two-wire, 18 AWG shielded cable from the wall transformer to the enclosure. The AC input must be supplied at 16.5 VAC utilizing one of the following UL-listed, 50 VA, Class 2 transformers: Basler Electric Model BE156250CAA0004, M&G Electronics Model MGT1650, or Honeywell Access Systems part number X-4. The AC voltage is non-polarized and connects to TB17-1 and TB17-2. **Caution:** Do not plug in the wall transformer at this time, and do not connect to a receptacle controlled by a switch.
5. Run a 14 AWG green wire from the enclosure to a proper earth ground.
6. Remove each terminal plug one at a time to wire the properly labeled cables. See the wiring diagram ([Figure 33](#) on page 47). Leave enough shield drain length to secure to the grounding stud. Also, maintain a distance of at least .25 inches between the non-power limited wiring (battery backup/charger wiring) and all other wiring, which is power-limited Class 2 wiring. **Caution:** Do not plug in the wall transformer at this time.
7. Connect the shield and the green earth ground to the enclosure's grounding studs (see [Figure 1](#) on page 6) for the location of the enclosure's grounding studs).
8. Set DIP switch settings for the panel address ([Table 3](#) on page 22), and set J36 and J37 for communication termination and biasing (see "[System Configuration](#)" on page 26 and "[Jumper Settings](#)" on page 23).
9. Check all wiring at this time. **Caution:** Improper wiring can cause damage to the NetAXS™ panel at power up resulting in a loss of warranty.
10. Power up the panel. The power-up sequence may take up to two minutes, after which the RUN LED blinks green. The RUN LED is located near Terminal Block (TB) 8. After the power-up sequence, check the LEDs to be sure the panel has powered up properly (see "[LED Operation](#)" on page 42).
11. Configure the panel by following the instructions in the *NetAXS™ Access Control Unit User's Guide*.
12. If you are using a battery backup function, place the 7 A-Hr battery in the enclosure.
13. Attach the positive (red) Power Supply-to-Battery cable to the positive (red) battery terminal.

14. Attach the negative (black) Power Supply-to-Battery cable to the negative (black) battery terminal.
15. For panels using the Ethernet connection, the cable clamp (HAS part number 3-000342) must be used for the panel to pass the FCC Part 15 Class B requirements. Snap the clamp around any portion of the Ethernet cable that is inside of the enclosure.

4.1 Cabinet Mounting

The following five figures show the back, top, bottom, right, and left views of the NetAXS™ panel cabinet. Each view includes the dimensions and knockout placement that you will need to mount the cabinet. All dimensions are given in inches. See [Table 1](#) on page 14 for dimensions of the conduit entries into the cabinet.

Figure 2: NetAXS™ NX4S1 Panel Cabinet, Front View

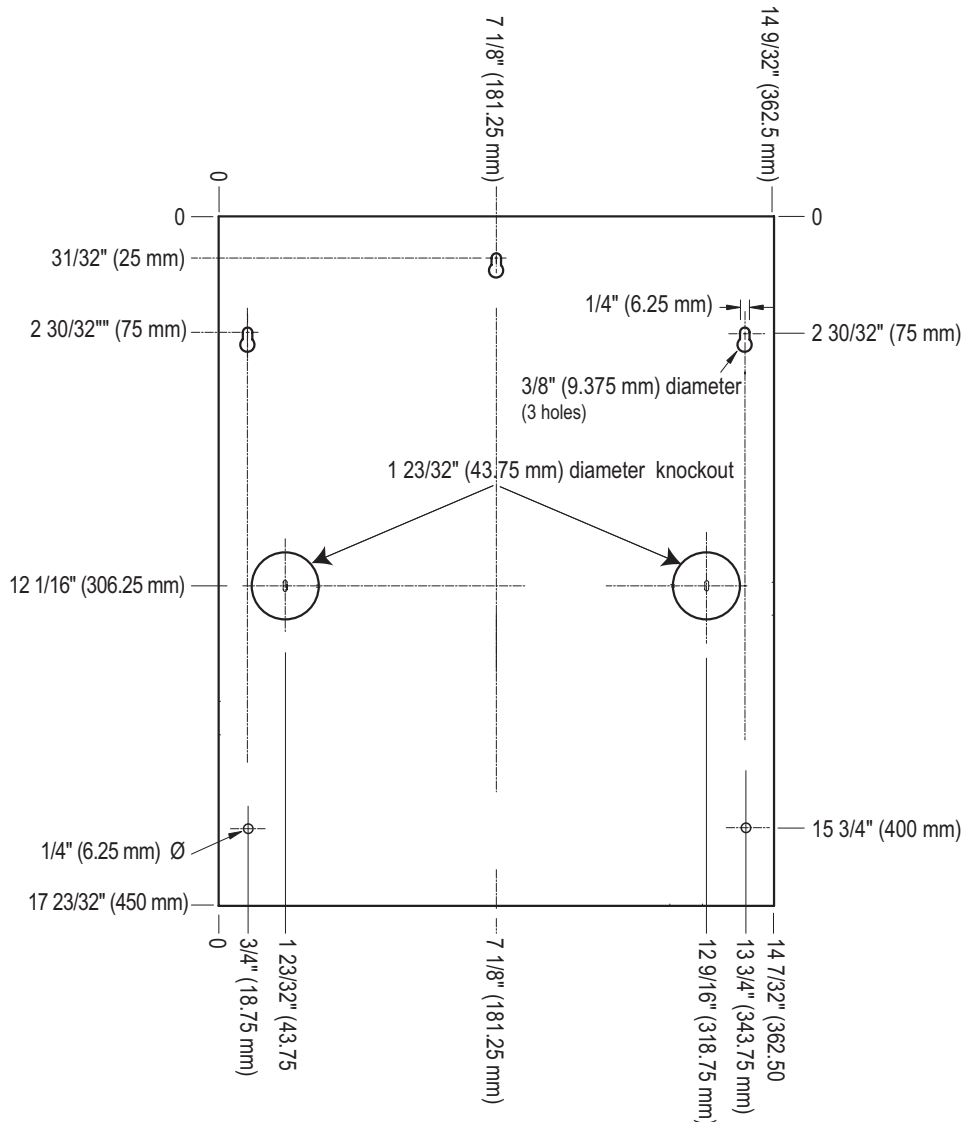

Figure 3: NetAXS™ NX4S1 Panel Cabinet, Top View

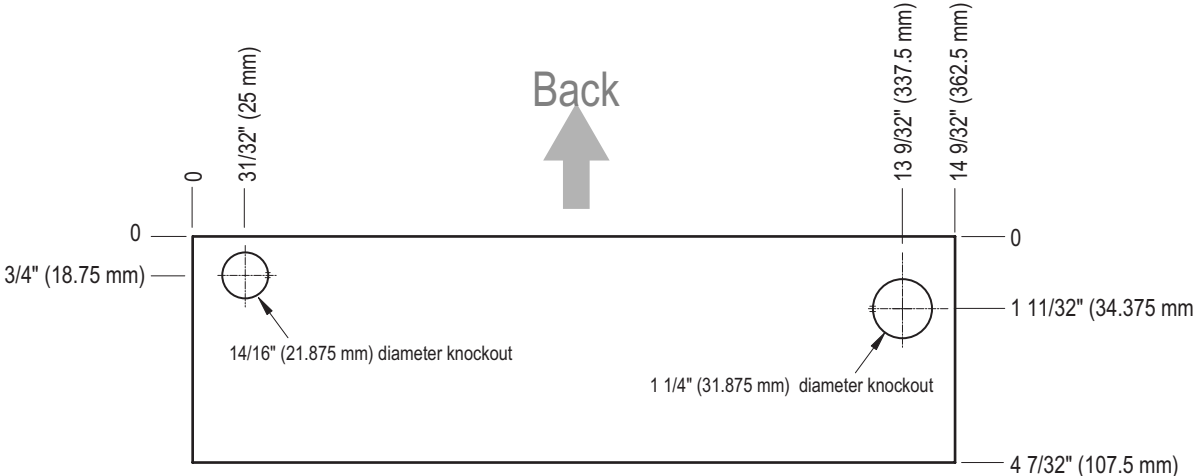

Figure 4: NetAXS™ NX4S1 Panel Cabinet, Bottom View

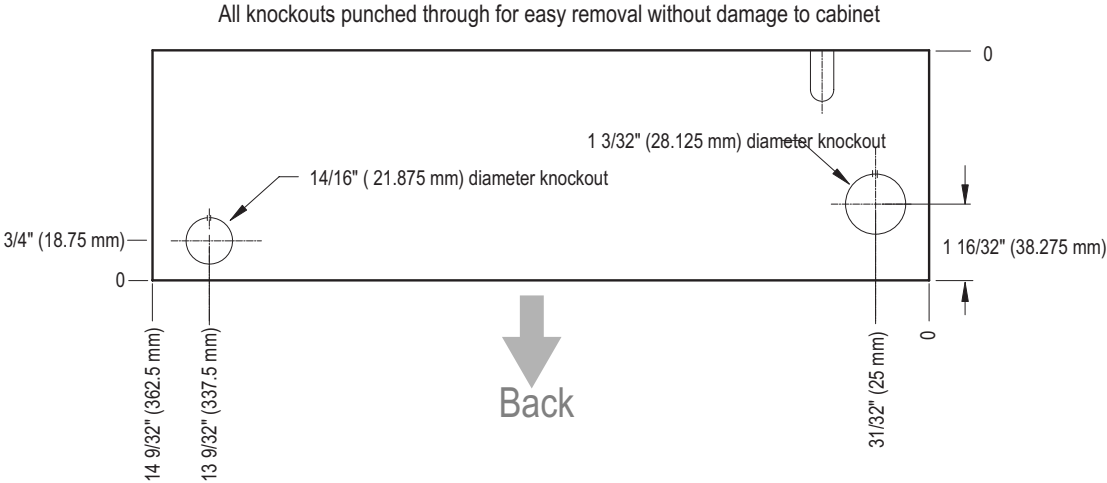

Figure 5: NetAXS™ Panel Cabinet, Left View

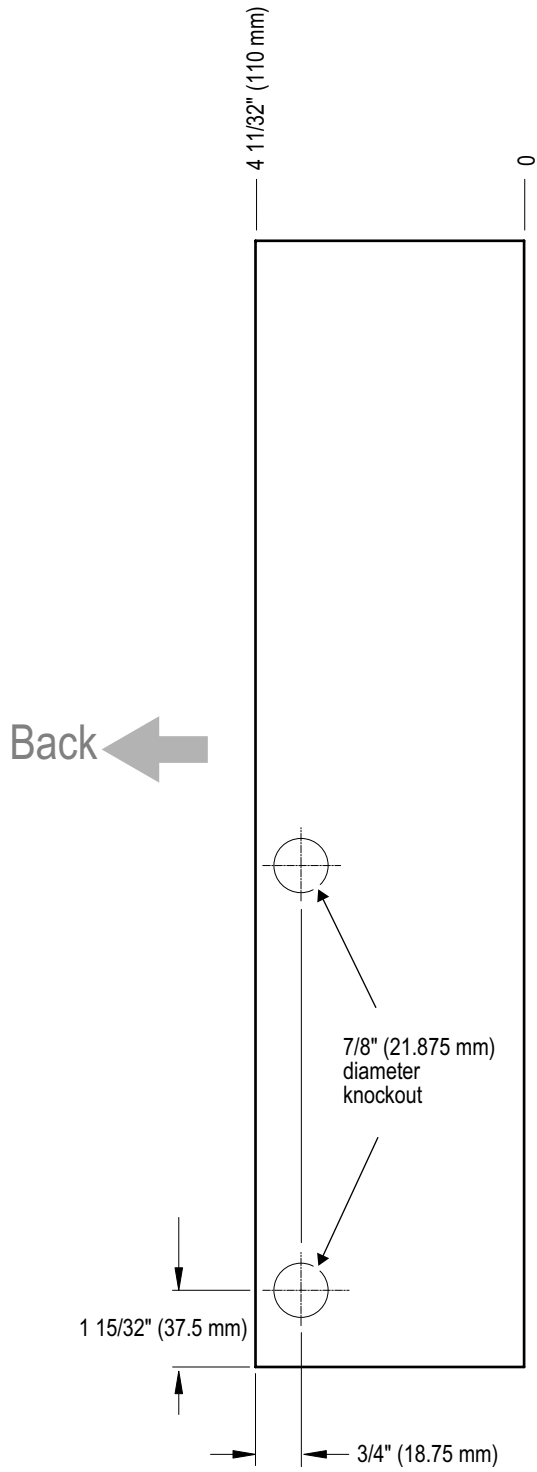
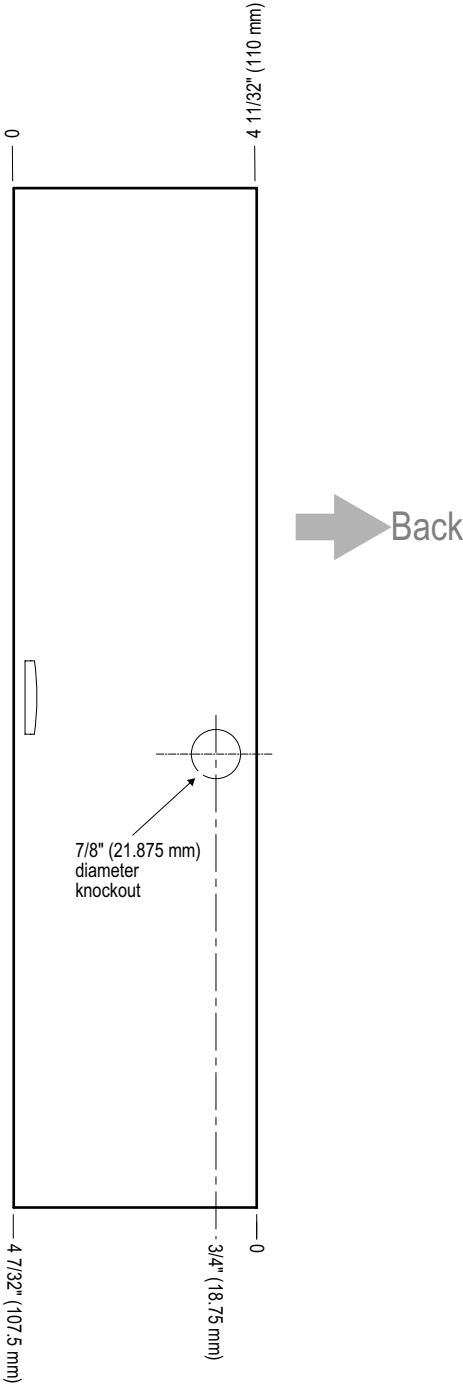

Figure 6: NetAXS™ NX4S1 Panel Cabinet, Right View



4.2 Reader Wiring

Each reader port supports a single 12-volt reader with Wiegand output format. Power to the readers is shared with the AUX Power ports TB3 and TB14. The maximum power draw is 600 mA for readers and AUX Power combined.

To fully utilize each reader port, a shielded 7-conductor cable (18-22 AWG) is required. If the optional reader buzzer feature is not needed, you can use the standard six-conductor cable (HAS part number NC1861-BL). The cable shield should be grounded at the panel only. Grounding at both ends can cause ground loops which can be disruptive. The maximum recommended length of wiring is 500 feet per reader.

Table 1 Reader Wiring

Terminal	Wire Color	Wiegand Reader
TB5-1, 6-1, 11-1, 12-1	Brown	LED Control
TB5-2 6-2, 11-2, 12-2	Green	Wiegand Data 0 or Data
TB5-3, 6-3, 11-3, 12-3	White	Wiegand Data 1 or Clock
TB5-4, 6-4, 11-4, 12-4	Black	Common
TB5-5, 6-5, 11-5, 12-5	Red	12VDC Power
TB5-6, 6-6, 11-6, 12-6	Variable	Tamper
TB5-7, 6-7, 11-7, 12-7	Variable	Buzzer

4.3 Supervised Input Wiring

The supervised inputs are located on TB4 and TB13 (Figure 7 on page 15). Input 1 through Input 8 may be configured for normally open or normally closed contacts as supervised or non-supervised. Inputs 13 and 14 are on TB8. All eight inputs have default functions, but they can be configured for general purpose inputs.

The following table identifies the default function for each terminal position.

Table 2 Default Supervised Input Assignments

Terminal Position	Default Function
TB4-1	Door 1 REX (Egress)
TB4-3	Door 1 Status
TB4-4	Door 2 REX (Egress)

Table 2 Default Supervised Input Assignments (continued)

Terminal Position	Default Function
TB4-6	Door 2 Status
TB8-1	External Power Supply AC FAIL
TB8-3	Panel Tamper
TB13-1	Door 3 REX (Egress)
TB13-3	Door 3 Status
TB13-4	Door 4 REX (Egress)
TB13-6	Door 4 Status
TB 5-6, 6-6, 11-6, 12-6	Optional supervised input if not used for a reader tamper

The following figure shows the typical wiring for a supervised input.

Figure 7: Typical Supervised Input Wiring Diagram

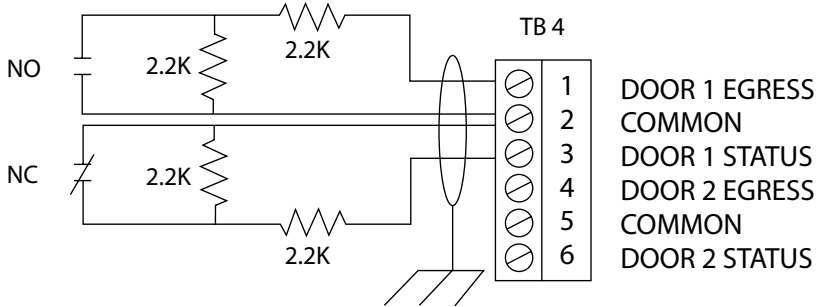

The figure above shows standard 2,200 ohm resistors. The NetAXS™ panel accepts 1,000, 2,200, 4,700, or 10,000 ohm values. Note that both resistors must have the same value. See the *NetAXS™ Access Control Unit User’s Guide* for instructions on selecting resistor options.

In addition, the Tamper and External Power Fail, as well as the Reader and Panel tampers can be supervised and capable of being used as additional inputs if the default functionality is not needed. They also share a single common.

The wire used for the inputs should be shielded and cannot exceed 30 ohms over the entire length of the cable. Remember that the distance from the panel to the door must be doubled to determine the total resistance.



Caution: The cable shield should be grounded only at the panel earth ground. Grounding at both ends can cause ground loops which can be disruptive.

Caution: The system has not been verified for compliance with UL1076 Burglar Alarm units and systems.

4.4 NX4S1 Control Output Wiring

Relay 1 is defaulted for control of the Door 1 lock, Relay 2 is defaulted for the control of the Door 2 lock, Relay 3 is defaulted for the control of the Door 3 lock, and Relay 4 is defaulted for the control of the Door 4 lock. Relays 5-8 are used as auxiliary relays. Refer to the *NetAXS™ Access Control Unit User's Guide* for details on controlling the relay operations.

Each relay also has a green indicator LED, which indicates the relay state. If the relay is active, the LED is illuminated.

Power for the door locks or auxiliary loads must be supplied from a separate external power supply.

A UL-listed system's power supply must also be UL-listed for this application.



Caution: The cable used must be sized for the current load and should be shielded. The cable shield should be grounded at the panel only. Grounding at both ends can cause ground loops which can be disruptive. Do not bundle these wires with communication, reader, or supervised input wiring.

To minimize premature contact failure and increase system reliability, a contact protection circuit (HAS part number S-4) is highly recommended. Locate the protection circuit as close as possible to the load.

4.5 Communications



Caution: Do not route communication wires with power or locking devices.



Note: Because UL has reviewed the NetAXS™ panel only as a standalone system, the computer terminal, NetAXS™ gateway panel, and N-485_PCI-2 adapter appear in this section's figures only to illustrate the installation and programming of the NetAXS™ panel.

RS-232 Communications

The NetAXS™ panel communicates with a PC through a 50-foot RS-232 cable (HAS part number CBL50). Connect the RJ45 end of the cable to the jack on the NetAXS™ panel.

The cable is used to provide communication to a single panel. A second cable can be used with another NetAXS™ control panel connected to a second COM (communication) port, which would enable eight readers to be used, see [Figure 9, RS-232 Configuration](#). A USB converter is also available that will provide RS-232 communications.

Figure 8 on page 17 illustrates the connections for an RS-232, DB9 (9 pin) connector to the panel's RJ-45 serial port. Replacement cables can be obtained by contacting your Honeywell Access System Representative.

Figure 8: RJ-45 Serial Port

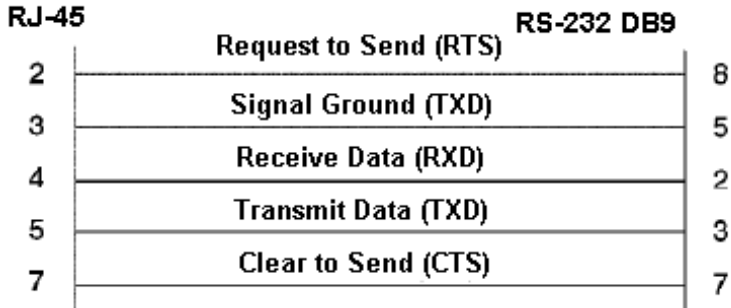
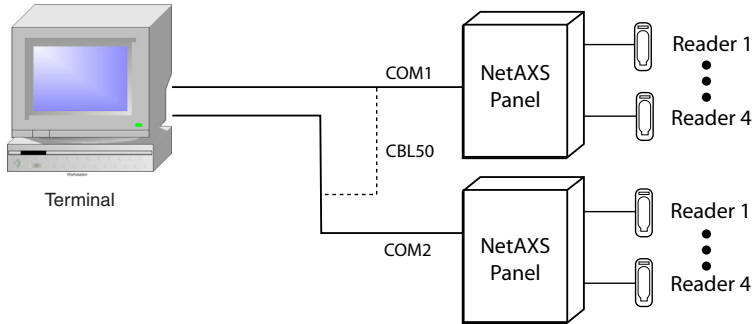

Figure 9: RS-232 Configuration



One NetAXS panel per COM port. Two COM ports possible.

RS-485 Communications

The NetAXS™ panel can reside on an existing RS-485 drop line hosted by either a NetAXS™ panel configured as a Gateway, or N-485-PCI-2, PCI-3, or N-485-HUB-2 (see [Figure 10](#) on page 18, [Figure 11](#) on page 19, and [Figure 23](#) on page 33). The interface allows the wiring of a Multidrop communication network of up to 4,000 feet (1200 m) in length. Only one host converter device per dropline is supported.



Note: On a Multidrop line, the Gateway panel and the PCI unit can have either end-point or interior positions. See [Figure 18](#) on page 28 and [Figure 19](#) on page 29 for illustrations.

DIP switch position 6 on the NetAXS™ panel selects whether the panel is a Gateway or Multidrop panel. The switch in the OFF position configures the panel as a Multidrop panel; ON configures a Gateway. The panel must be power cycled for a new switch setting to be recognized. DIP switch positions 1-5 are used to select the panel's address on the network. Refer to [Table 3](#) for DIP switch setting information.

Connectors J36 and J37 are provided for supplying biasing and end-of-line termination for the RS-485 network. The board ships with all jumpers open. For a Multidrop RS-485 line, you must close both J36 and J37 (terminated and biased) at the two end-point panels. At all other panels, leave J36 and J37 open. Both jumpers on a given panel must set the same. Note that biasing and termination on both ends are present. Use the jumpers on both ends of the RS-485 network.



Note: If an RS-485 network has a NetAXS™ Gateway panel, no N1000-II, N1000-III, or N1000-IV are allowed on the same network. If they are added to a network with a NetAXS™ Gateway panel, they will not be able to communicate with the host computer.

Figure 10: RS-485 Configuration via N-485-PCI-2 or PCI-3

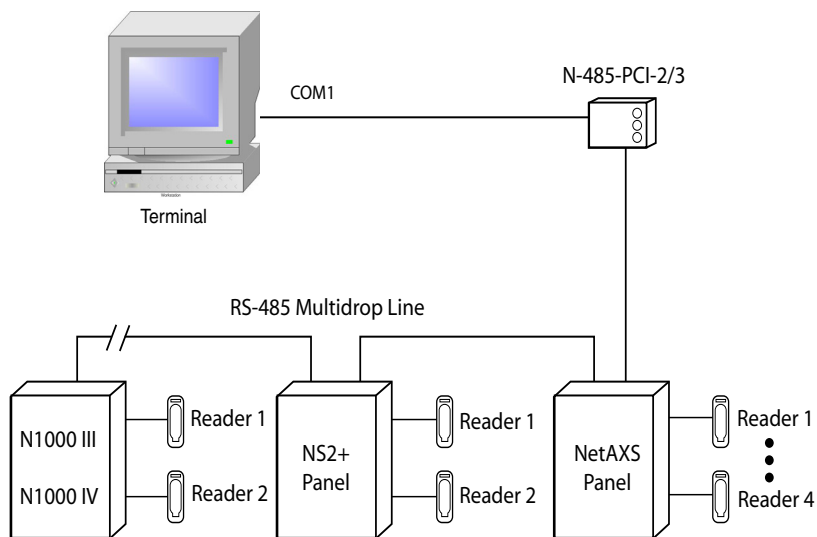

A combination of N1000 III, N1000 IV, NS2+ and NewAXS panels, supporting a total of 31 panels per multi-drop line

Figure 11: RS-485 Configuration via NetAXS™ Gateway

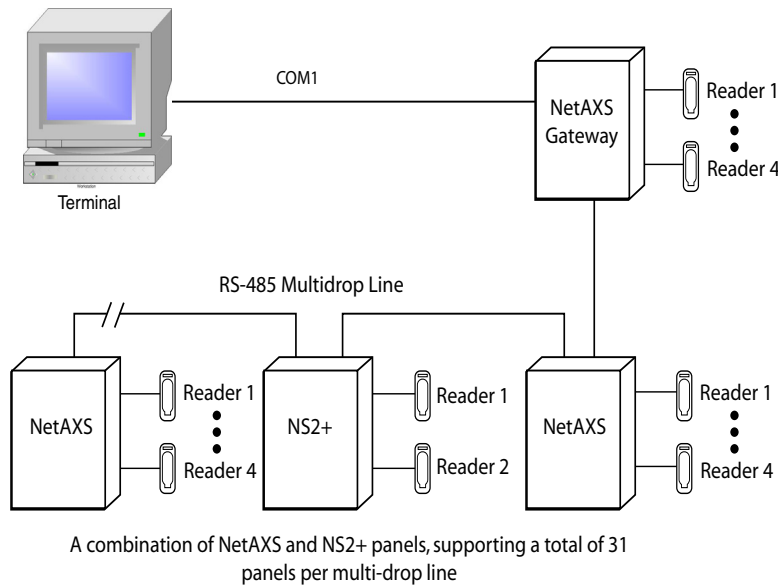

Ethernet TCP/IP Communications

Figure 12: Ethernet TCP/IP Configuration

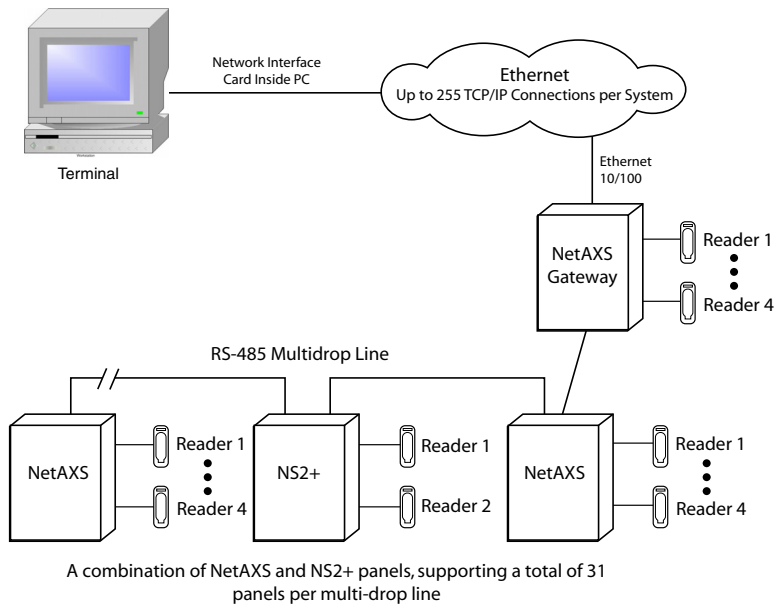

Each NetAXS™ panel has a port for an Ethernet TCP/IP interface (see [Figure 12, Ethernet TCP/IP Configuration](#)). The Ethernet TCP/IP interface provides 10/100 Mbit Ethernet support for each panel. Up to 31 panels can be configured on each TCP/IP connection.

Figure 13 on page 20 shows the location of the panel's unique MAC ID.

Figure 13: Ethernet MAC Address Location

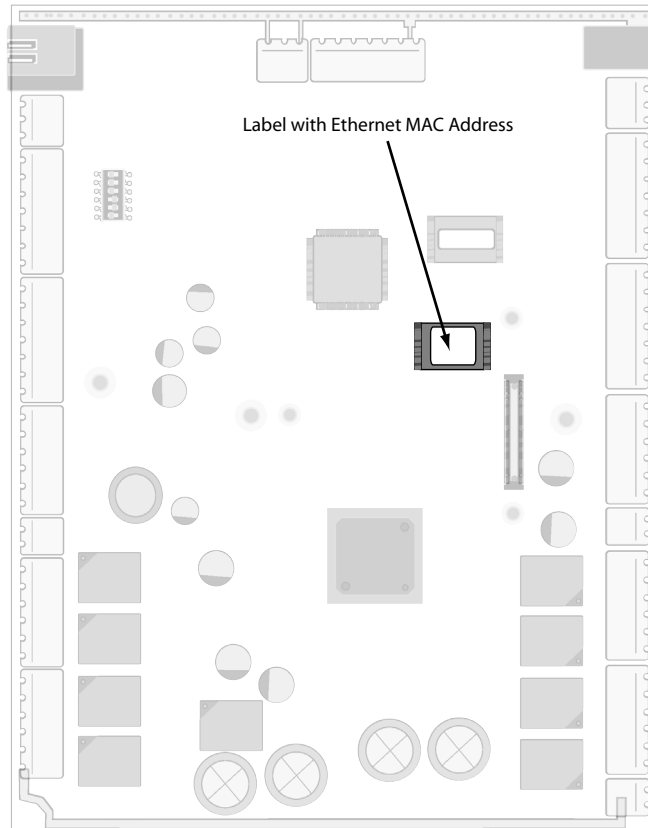

4.6 DIP Switch Settings

Figure 14 on page 21 locates the NX4S1 DIP switch panel and the J36 and J37 (termination and biasing) jumpers.

Figure 14: DIP Switch and Jumper Locations

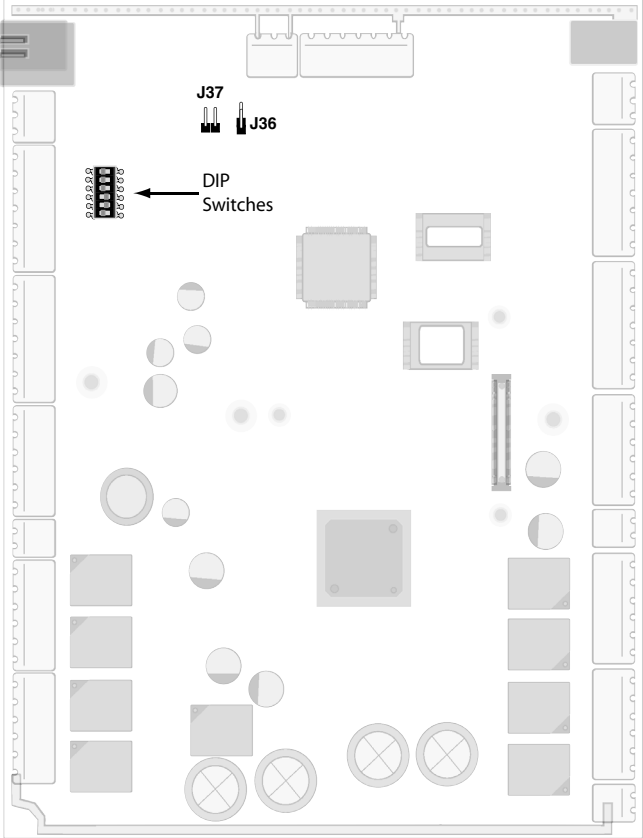

Use the following DIP switch configurations to set the panel address.

Table 3 DIP Switch Settings

S1	S2	S3	S4	S5	S6	Selection
on	off	off	off	off		Address 1 (default)
off	on	off	off	off		Address 2
on	on	off	off	off		Address 3
off	off	on	off	off		Address 4
on	off	on	off	off		Address 5
off	on	on	off	off		Address 6
on	on	on	off	off		Address 7
off	off	off	on	off		Address 8
on	off	off	on	off		Address 9
off	on	off	on	off		Address 10
on	on	off	on	off		Address 11
off	off	on	on	off		Address 12
on	off	on	on	off		Address 13
off	on	on	on	off		Address 14
on	on	on	on	off		Address 15
off	off	off	off	on		Address 16
on	off	off	off	on		Address 17
off	on	off	off	on		Address 18
on	on	off	off	on		Address 19
off	off	on	off	on		Address 20
on	off	on	off	on		Address 21
off	on	on	off	on		Address 22
on	on	on	off	on		Address 23
off	off	off	on	on		Address 24
on	off	off	on	on		Address 25
off	on	off	on	on		Address 26
on	on	off	on	on		Address 27
off	off	on	on	on		Address 28
on	off	on	on	on		Address 29
off	on	on	on	on		Address 30
on	on	on	on	on		Address 31
					off	NetAXS™ Multidrop
					on	NetAXS™ Gateway



Note: Address 0 is not a valid setting for standard operations.

4.7 Jumper Settings

The NX4S1 panel control board includes jumpers 36 and 37, which set end-of-line termination and biasing for the Multidrop RS-485 line.

The board ships with all jumpers set to OFF. For a Multidrop RS-485 line, you must set both J36 and J37 to CLOSED (terminated and biased) at the two end-point panels. At all other panels, leave J36 and J37 at OPEN. Note that both jumpers on a given panel must either be OPEN or CLOSED.

4.8 Downstream I/O



Note: UL has not evaluated the compatibility of downstream I/O devices with the NetAXS™ panel.

In some applications, the number of system inputs or outputs exceeds the number that is standard on the NetAXS™ panel. The solution is to add a combination of MIRO-2/16 and MIRO-32/0 modules external to the NetAXS™ enclosure on a dedicated RS-485 Downstream Input/Output (I/O) bus. A maximum of two MIRO-32/0 and a maximum of four MIRO-2/16 for a total of six MIRO modules can be added to the downstream bus.

A MIRO-32/0 module has 32 supervised, four-state inputs that are limited to 1,000 ohms resistance. The MIRO-2/16 has two supervised inputs and 16 SPDT relay outputs; each input is limited to 1,000 ohms resistance. Refer to the individual installation manuals for I/O wiring details.

The downstream I/O bus is wired into the NetAXS™ TB10 terminal block. The downstream bus has a fixed baud rate and communicates to the MIRO modules using a polling technique.

Each MIRO module needs to have a unique address for proper communication. Each one also has some configuration jumpers that need to be positioned correctly.

The following table lists the DIP switch and jumper settings for the MIRO 32/0 and 2/16 modules.

Table 4 MIRO 32/0 DIP Switch and Jumper Settings

Module	Setting	Value
MIRO 32/0	DIP switches	Address (switches 1-6) - 1 or 2
		Baud rate (switches 7 and 8) - 7 = OFF, 8 = ON
		OP Mode (switches 9 and 10) - 9 = OFF, 10 = OFF

Table 4 MIRO 32/0 DIP Switch and Jumper Settings (continued)

Module	Setting	Value
	Jumper settings	JP1 - CLOSED (if the module is the last module on the downstream bus), OPEN (if the module is not the last module on the downstream bus)
		JP2 - any setting
		JP3 - any setting
		JP4 - NORMAL (Positions 1 and 2)
MIRO 2/16	DIP switches	Address (switches 1-6) - 3 through 6
		Baud rate (switches 7 and 8) - 7 = OFF, 8 = ON
		OP Mode (switches 9 and 10) - 9 = OFF, 10 = OFF
	Jumper settings	JP1 - CLOSED, positions 2 and 3 (if the module is the last module on the downstream bus); OPEN, positions 1 and 2 (if the module is not the last module on the downstream bus)
		JP2 - NORMAL, positions 1 and 2



Note: If a MIRO 32/0 is not required in a system, start addressing the 2/16 modules at DIP switch 3. If a MIRO 32/0 is configured with an address other than 1 or 2, the NetAXS™ panel will not communicate with it. Likewise, if a MIRO 2/16 is configured with an address other than 3 through 6, the NetAXS™ panel will not communicate with it.

The NetAXS™ board is not intended to provide either module power or module output load power for downstream I/O. A separate 24VDC supply should be used to provide power to all downstream modules and output loads. For some installations, the noise immunity improves if the NetAXS™ common is connected to the 24 VDC Return wiring for the downstream modules. This connection is not needed for most installations.

The following figure shows the default downstream I/O system configuration with communication and power wiring. This configuration has not been reviewed by UL.

Figure 15: Default Downstream I/O Configuration with Wiring

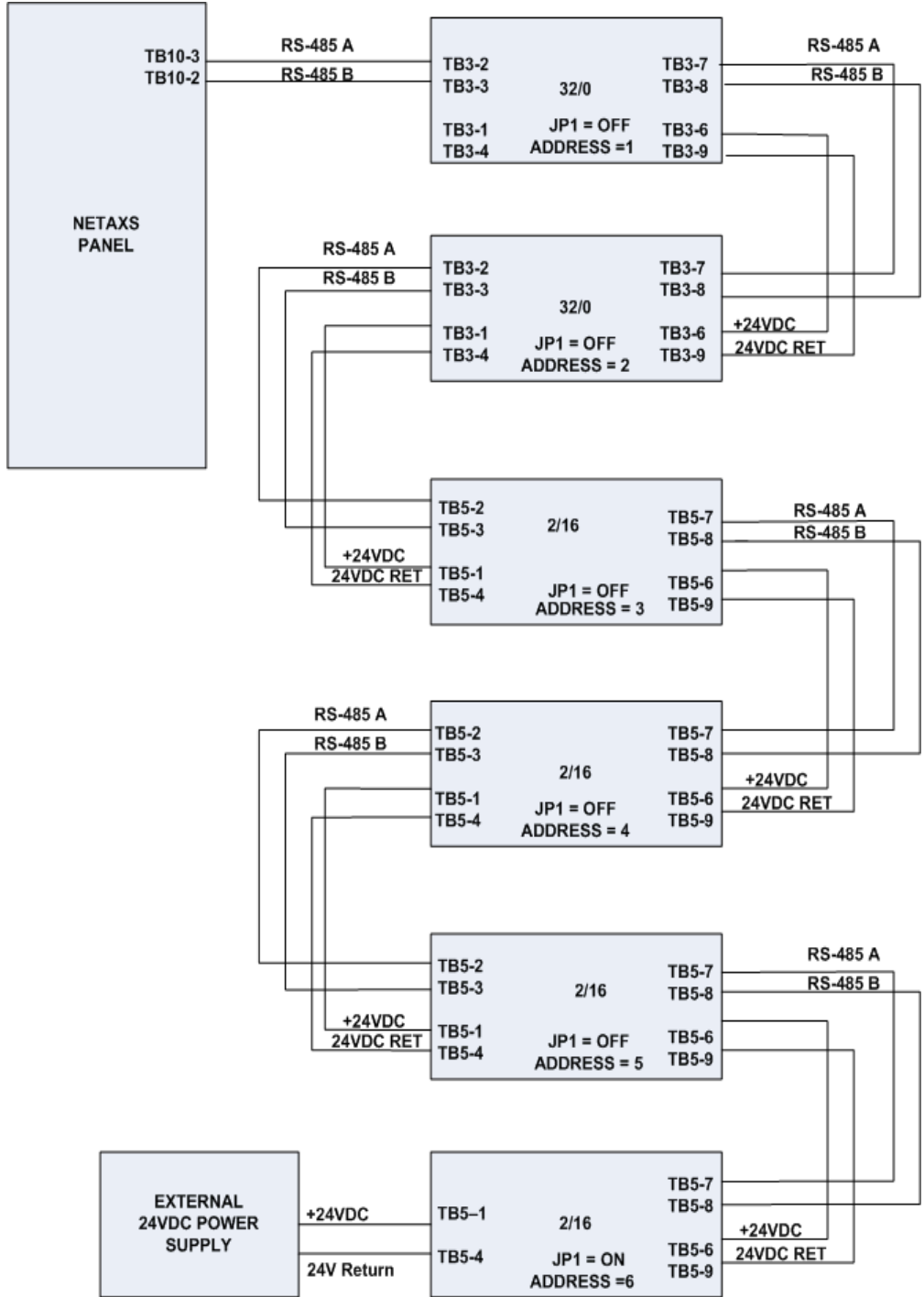

5.0 System Configuration

This section provides wiring diagrams for each of the NetAXS™ system configurations.

5.1 RS-485 Connection via PCI-2

This connection supports thirty-one NetAXS™ Access Controller panels for each drop line. It has been reviewed by Underwriters Laboratories Incorporated (UL). Note that PCI-2 units can also be wired anywhere along the drop line. See [Figure 18](#) on page 28 and [Figure 19](#) on page 29. Because UL has reviewed the NetAXS™ panel only as a standalone system, the computer terminal, NetAXS™ gateway panel, and N-485_PCI-2 adapter appear in this section only to illustrate the installation and programming of the NetAXS™ panel.

Figure 16: RS-485 Connection via PCI-2

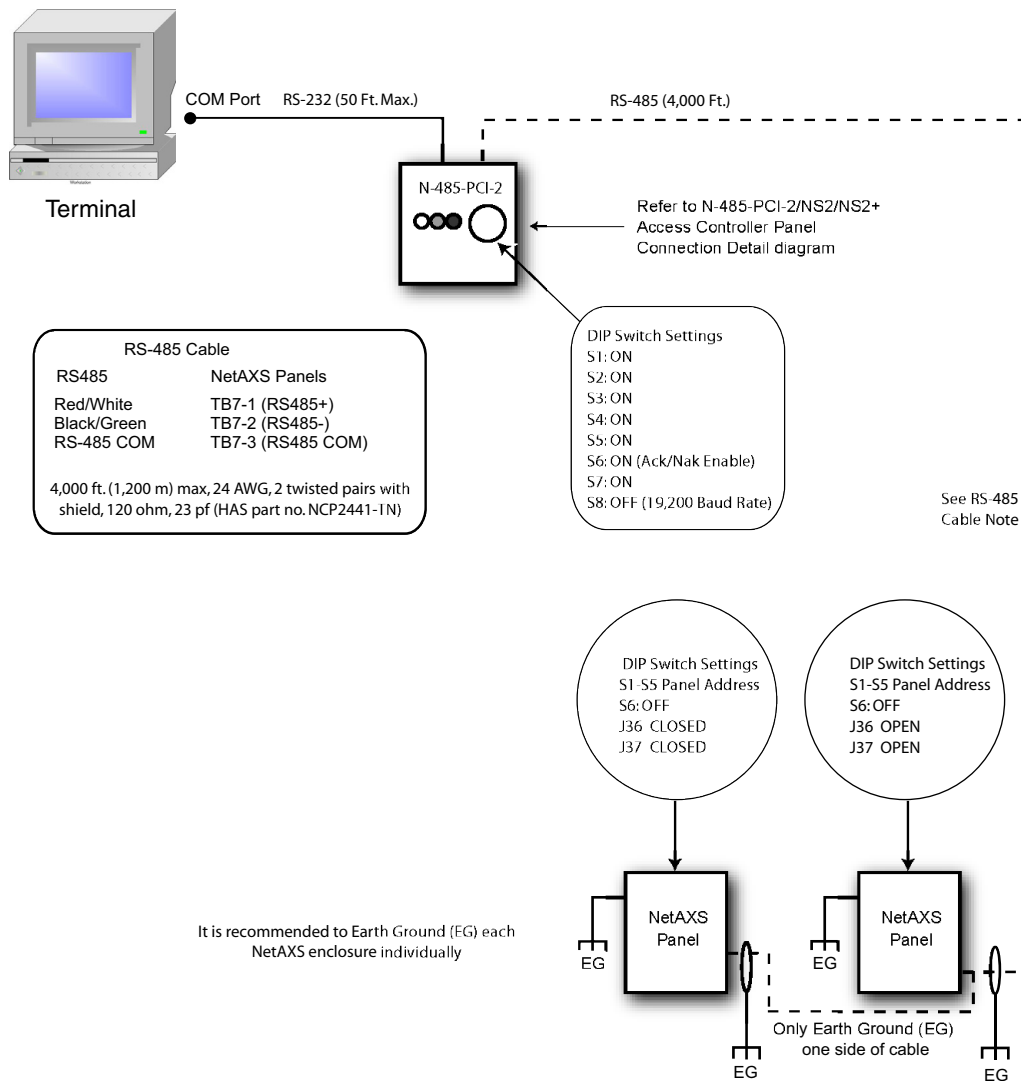

5.2 RS-485 Connection via NetAXS™

This connection supports thirty-one NetAXS™ Access Controller panels for each drop line. It has been reviewed by UL. However, because UL has reviewed the NetAXS™ panel only as a standalone system, the computer terminal and NetAXS™ gateway panel appear in this section only to illustrate the installation and programming of the NetAXS™ panel.

Figure 17: RS-485 Connection via NetAXS™

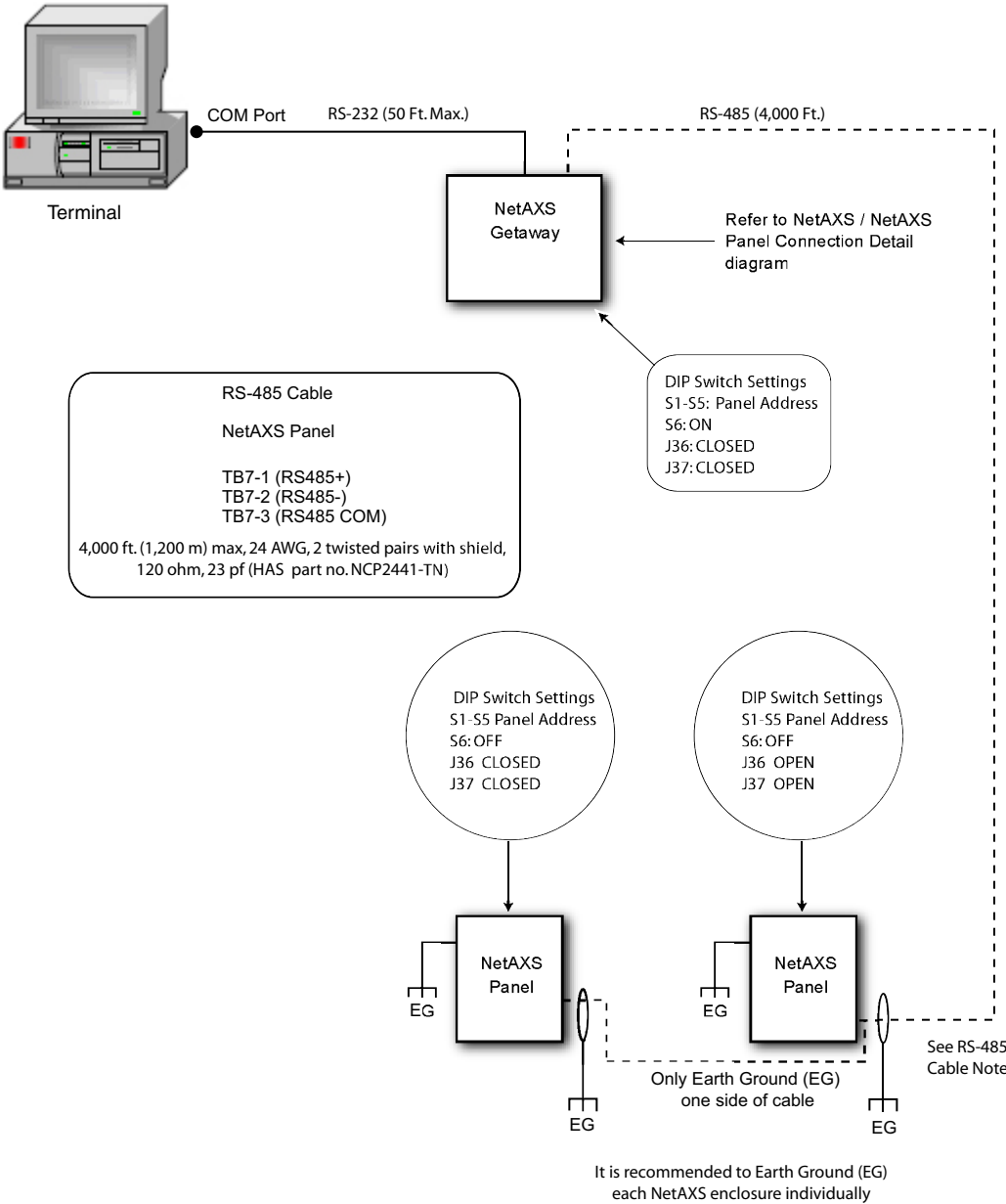

5.3 RS-485 Connections with Multidrop Panels at Both Ends of the Cable

You can connect Multidrop panels at both ends of an RS-485 cable via either a NetAXS™ panel or a PCI-2 device. These configurations have not been reviewed by UL.

Figure 18: RS-485 Connection via NetAXS™ with Multidrop Panels at Both Ends

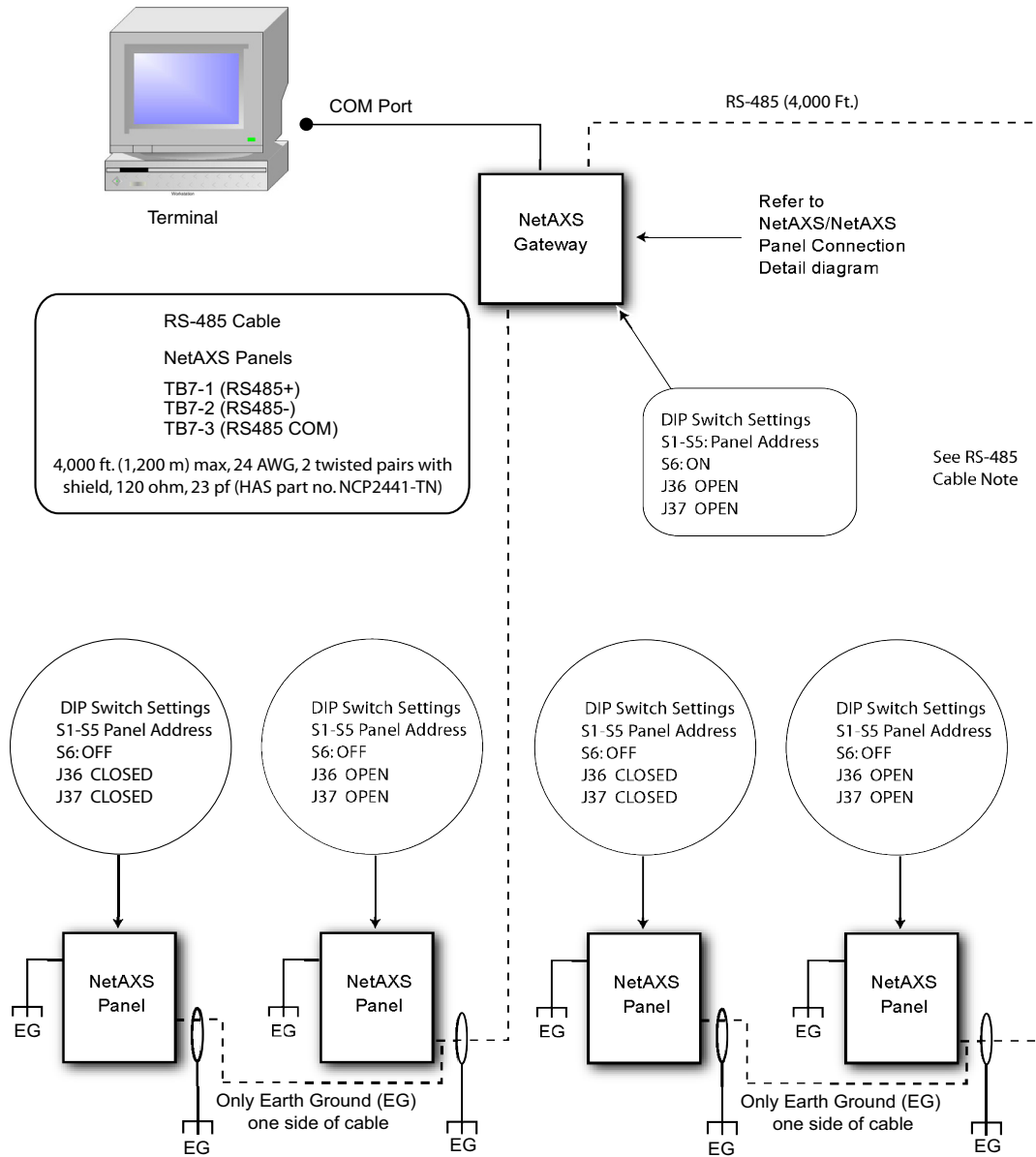

It is recommended to Earth Ground (EG) each NetAXS enclosure individual

Figure 19: RS-485 Connection via PCI-2 with Multidrop Panels at Both Ends

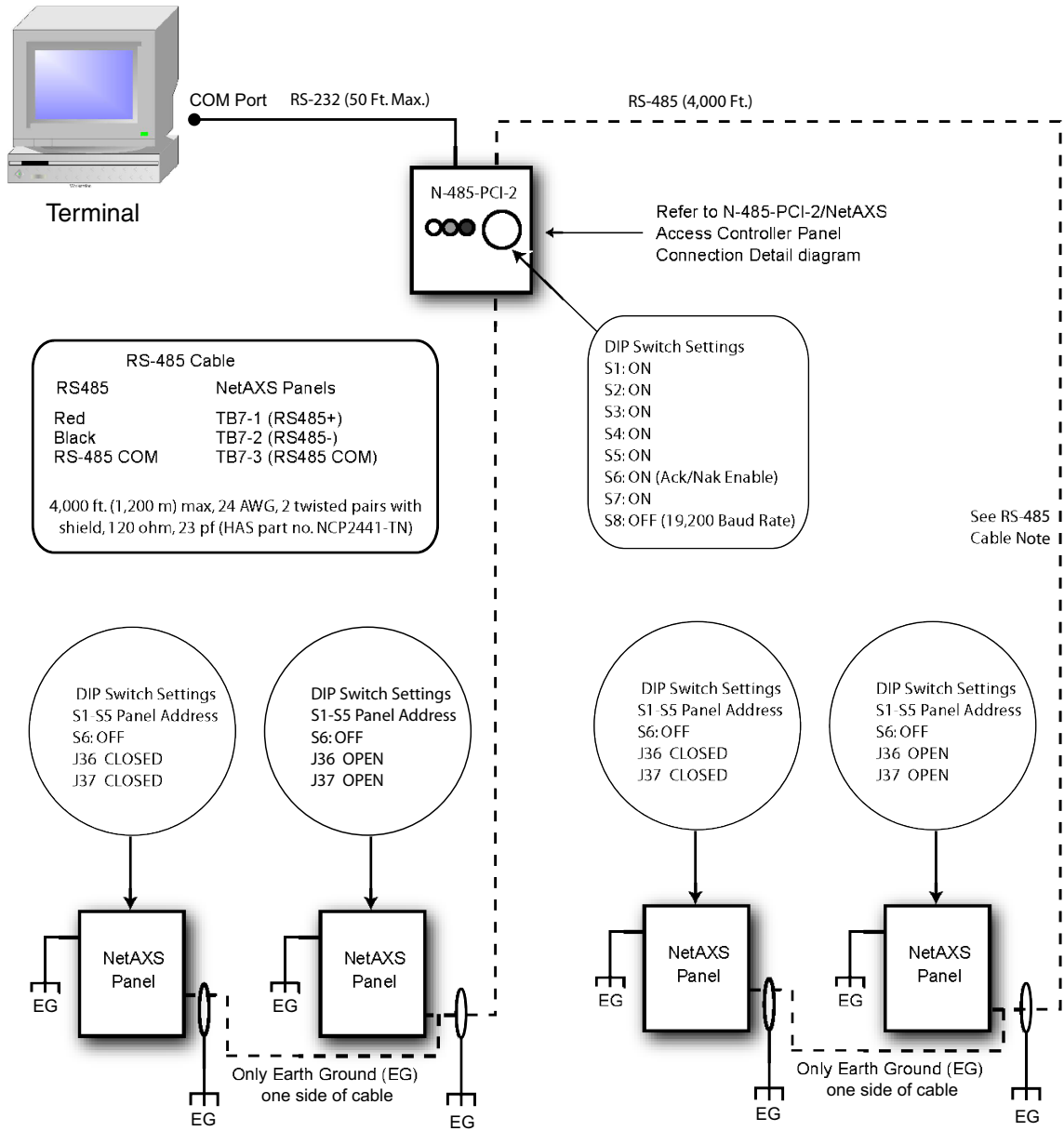

It is recommended to Earth Ground (EG) each NetAXS enclosure individually

5.4 RS-232 Connection

This connection supports one NetAXS™ Access Controller panel for each COM port. It has been reviewed by UL. However, because UL has reviewed the NetAXS™ panel only as a standalone system, the computer terminal and NetAXS™ gateway panel appear in this section only to illustrate the installation and programming of the NetAXS™ panel.

Figure 20: RS-232 Connection

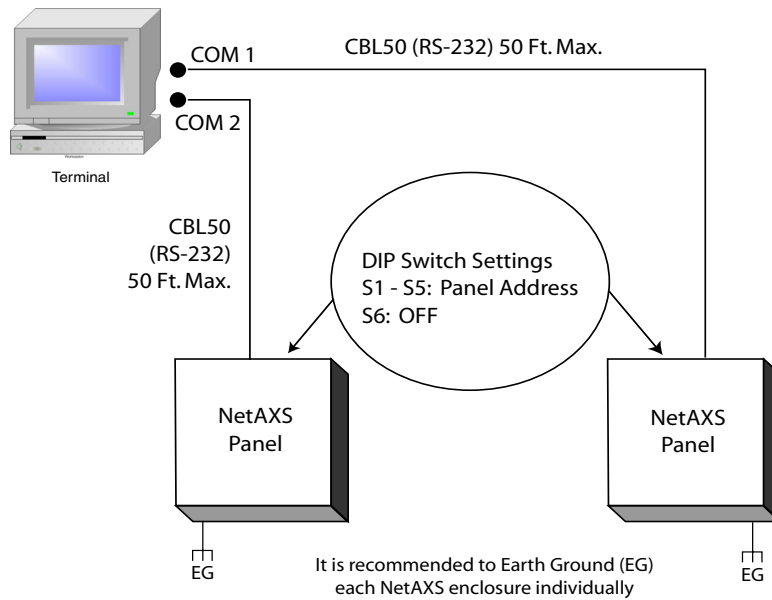

RS-232 (DB9)	CBL50 (RS-232)	RJ-45
8	Request To Send (RTS)	2
5	Signal Ground (GND)	3
2	Receive Data (RXD)	4
3	Transmit Data (TXD)	5
7	Clear To Send (CTS)	7

9-Pin COM 1 or COM 2 to RJ-45 on NetAXS Panel

5.5 Ethernet Connection

This connection supports a maximum of 255 IP connections per server. It has not been reviewed by UL.

Figure 21: Ethernet Connection

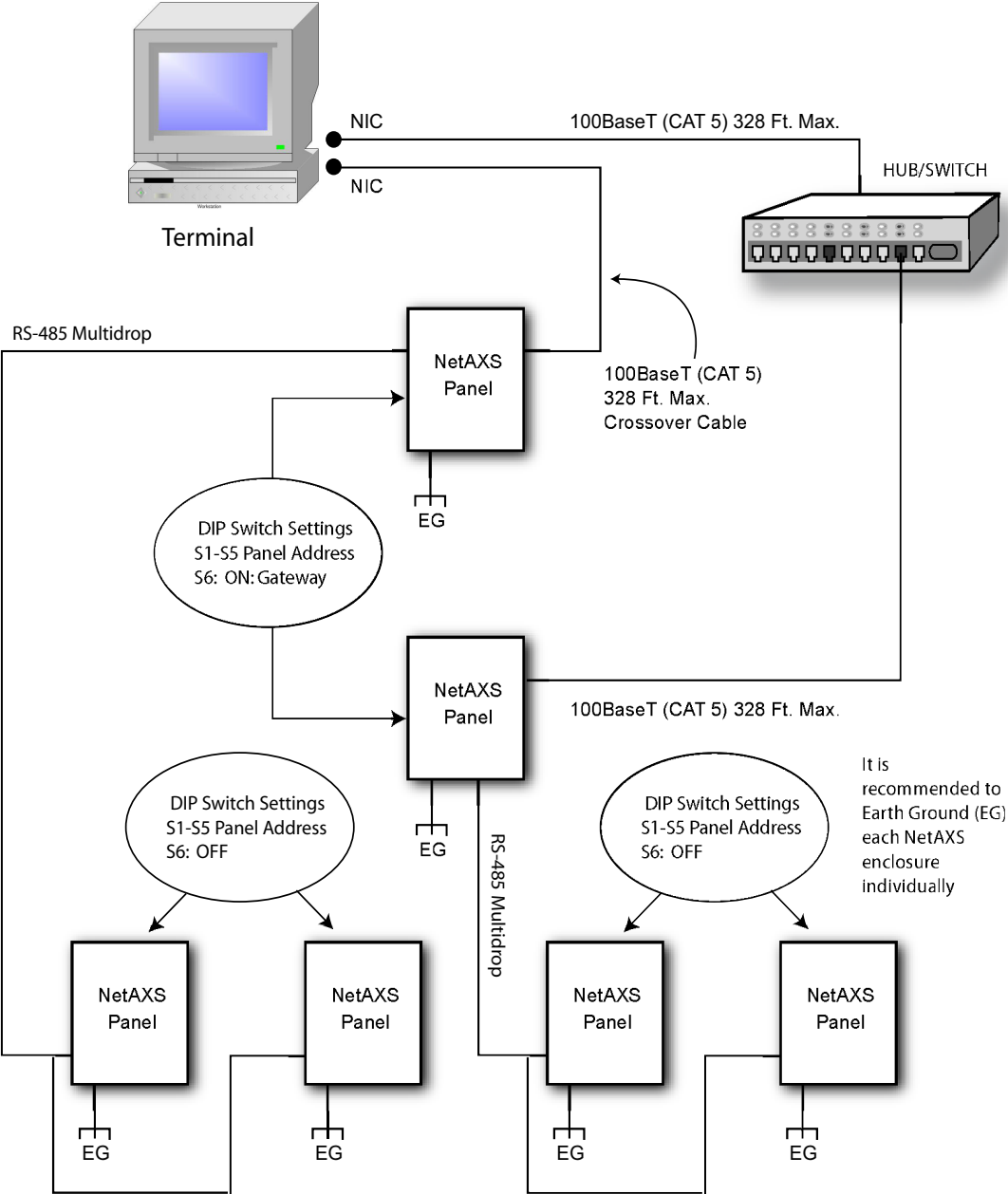

5.6 LANSRLU1 Connection

This connection supports thirty-one panels for each drop line and a maximum of 255 IP connections. It has not been reviewed by UL. Note that PCI-2 units can also be wired anywhere along the drop line. See [Figure 18](#) on page 28 and [Figure 19](#) on page 29.

Figure 22: LANSRLU1 Connection

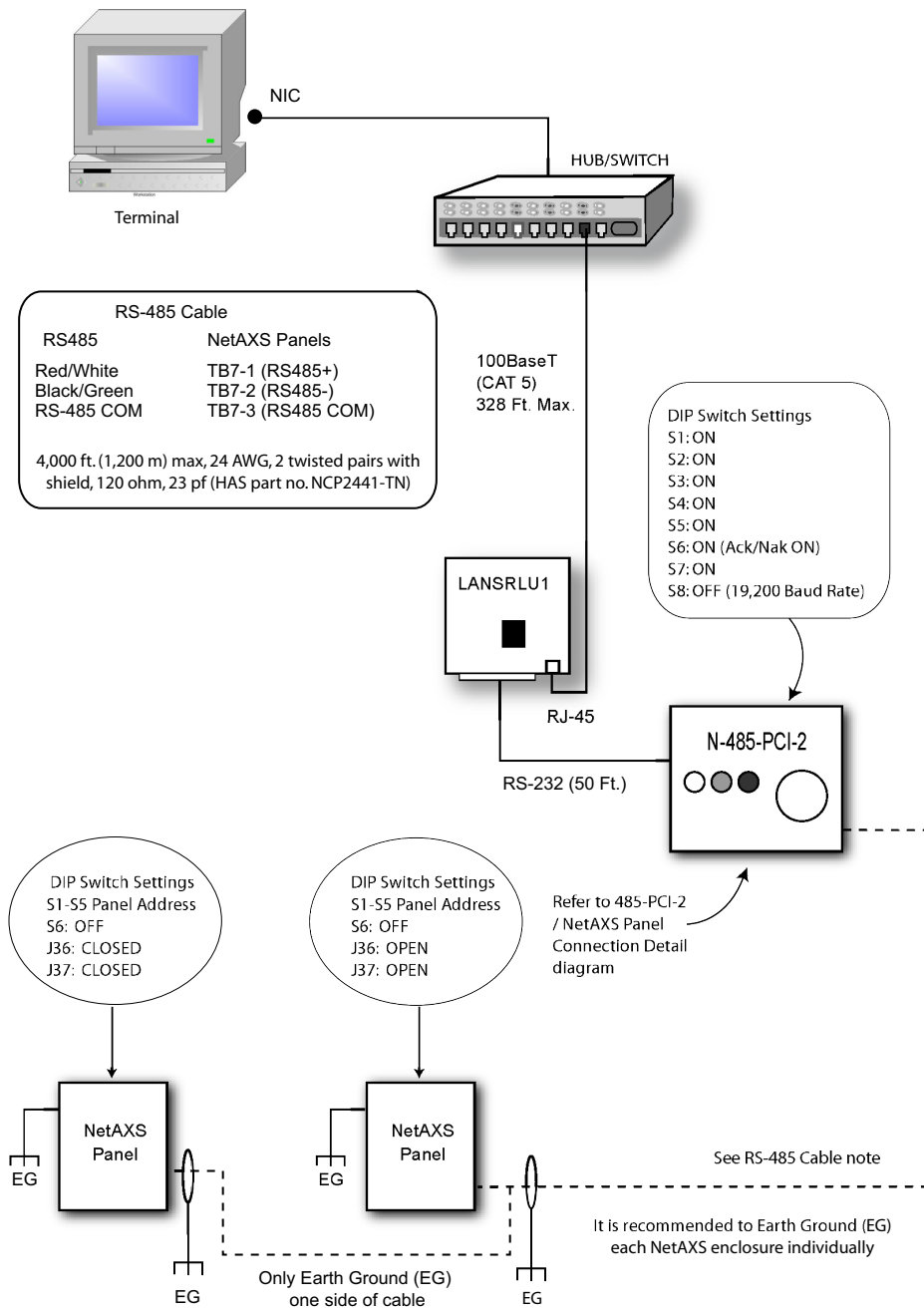

5.7 RS-485 Short Haul Modem Connection via PCI-2

This connection supports thirty-one NetAXS™ Access Controller panels for each drop line. It has not been reviewed by UL. Note that PCI-2 units can also be wired anywhere along the drop line. See [Figure 18](#) on page 28 and [Figure 19](#) on page 29.

Figure 23: RS-485 Short Haul Modem Connection via PCI-2

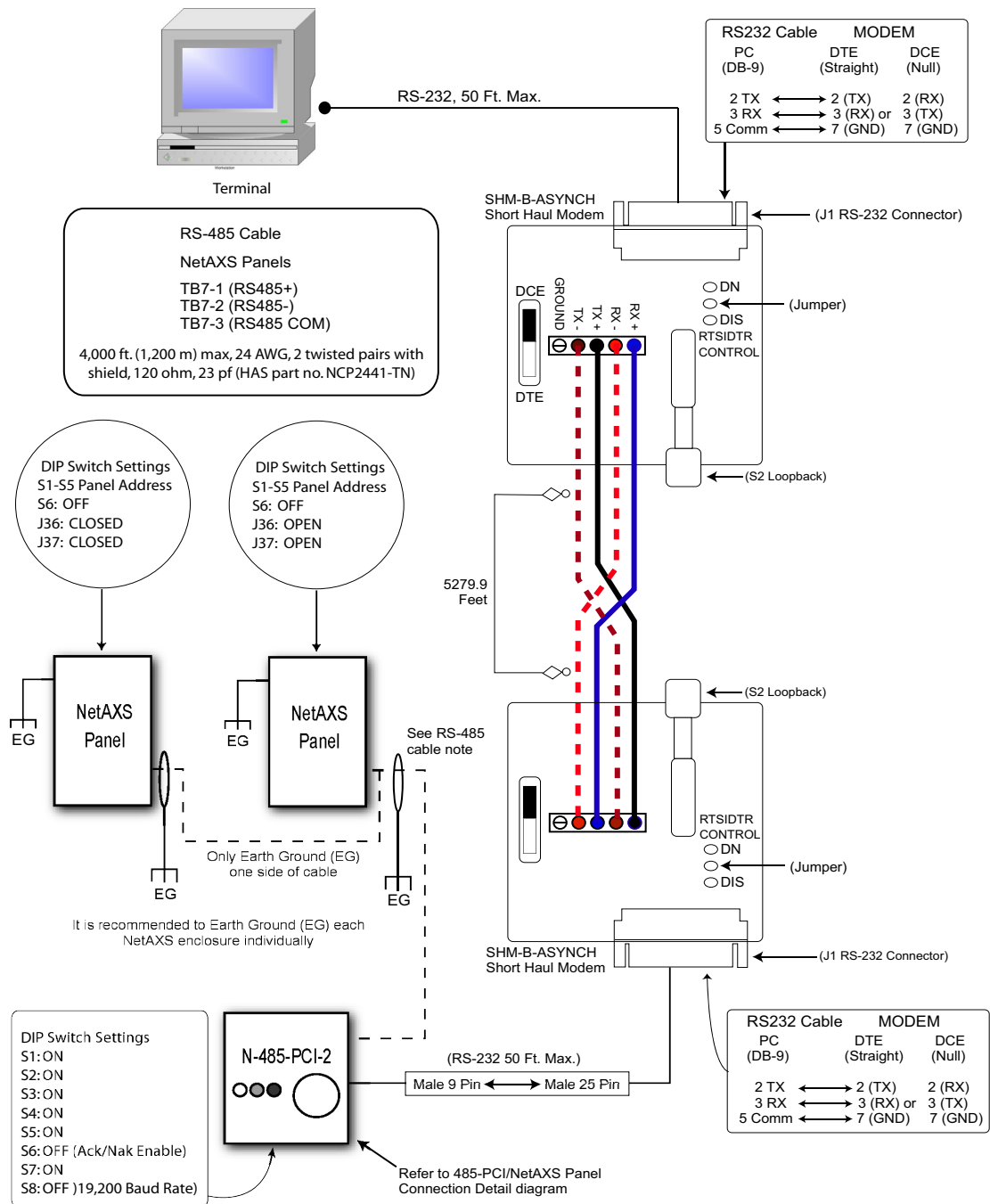

5.9 RS-232 Short Haul Modem Connection

One NetAXS™ Access Controller panel for each loop. It has not been reviewed by UL.

Figure 25: RS-232 Short Haul Modem Connection

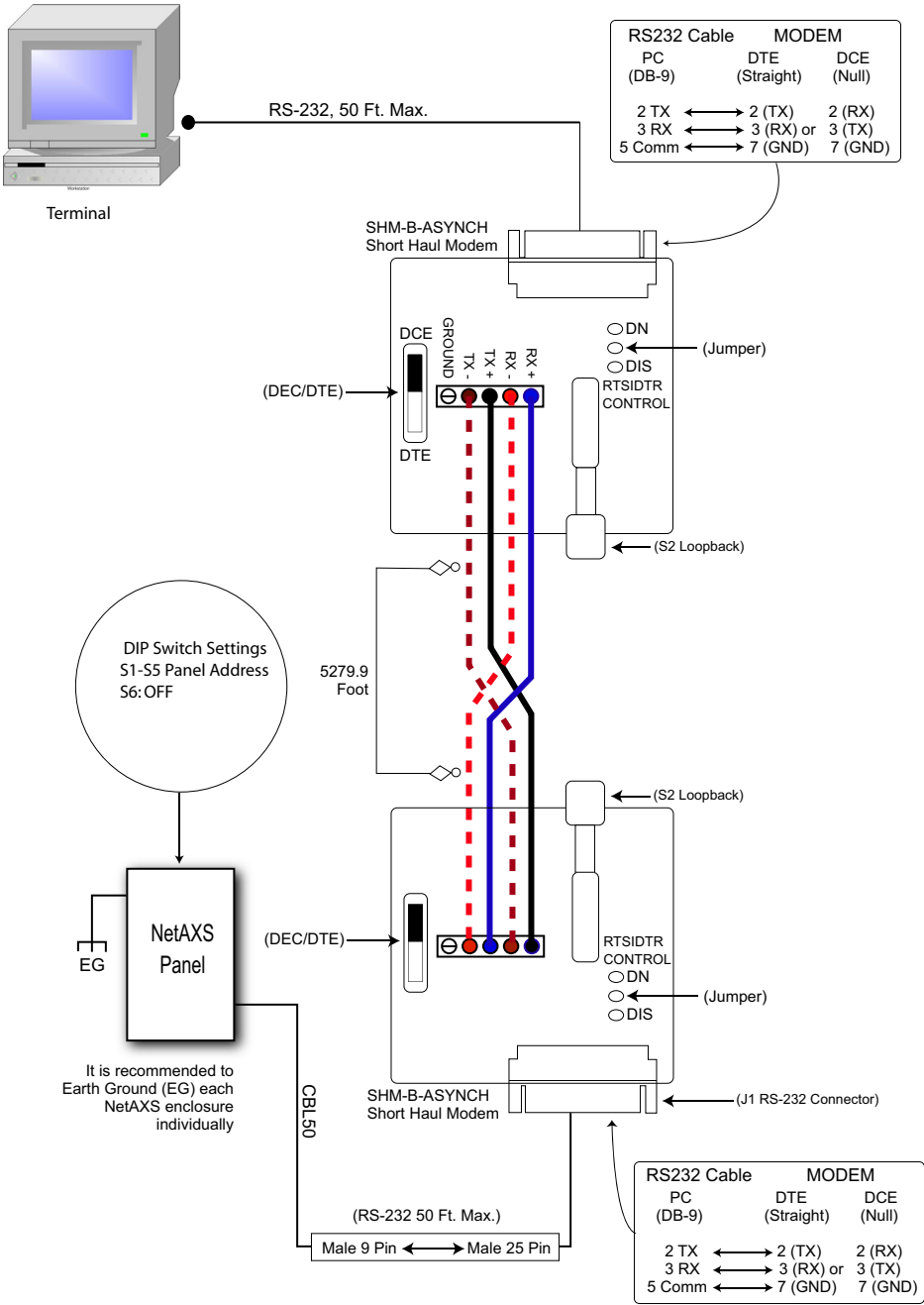

5.10 M-56K Dial-up Modem, RS-485 Connection via Hub

Thirty-one NetAXS™ Access Controller panels for each drop line. It has not been reviewed by UL.

Figure 26: M-56K Dial-up Modem, RS-485 Connection via Hub

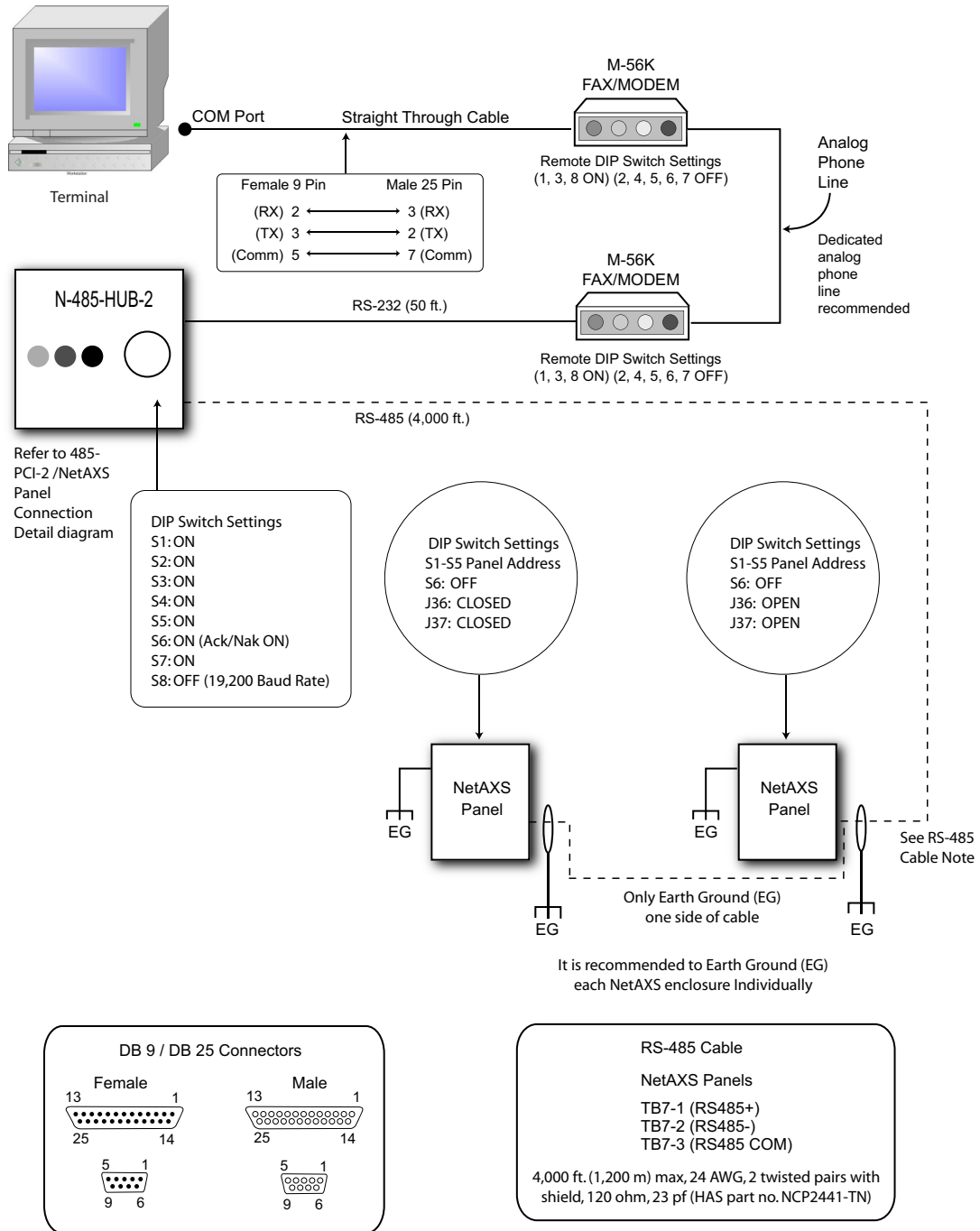

5.11 M-56K Dial-up Modem, RS-485 Connection via NetAXS™

Thirty-one NetAXS™ Access Controller panels for each drop line. It has not been reviewed by UL.

Figure 27: M-56K Dial-up Modem, RS-485 Connection via NetAXS™

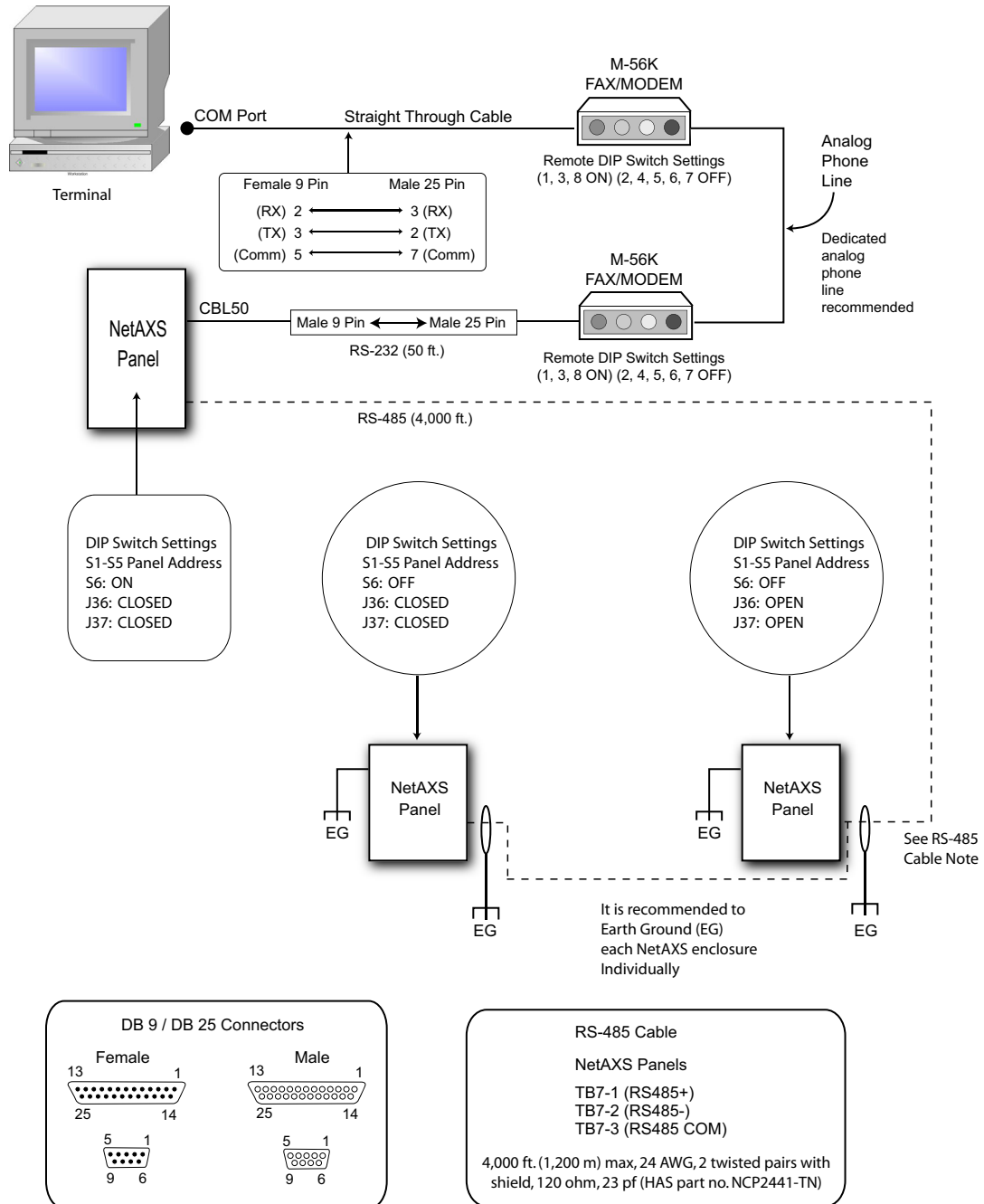

5.12 Fiber Converter to RS-485 Connection via PCI-2

This connection supports thirty-one NetAXS™ Access Controller panels for each drop line. It has not been reviewed by UL. Note that PCI-2 units can also be wired anywhere along the drop line. See [Figure 18](#) on page 28 and [Figure 19](#) on page 29.

Figure 28: Fiber Converter to RS-485 Connection via PCI-2

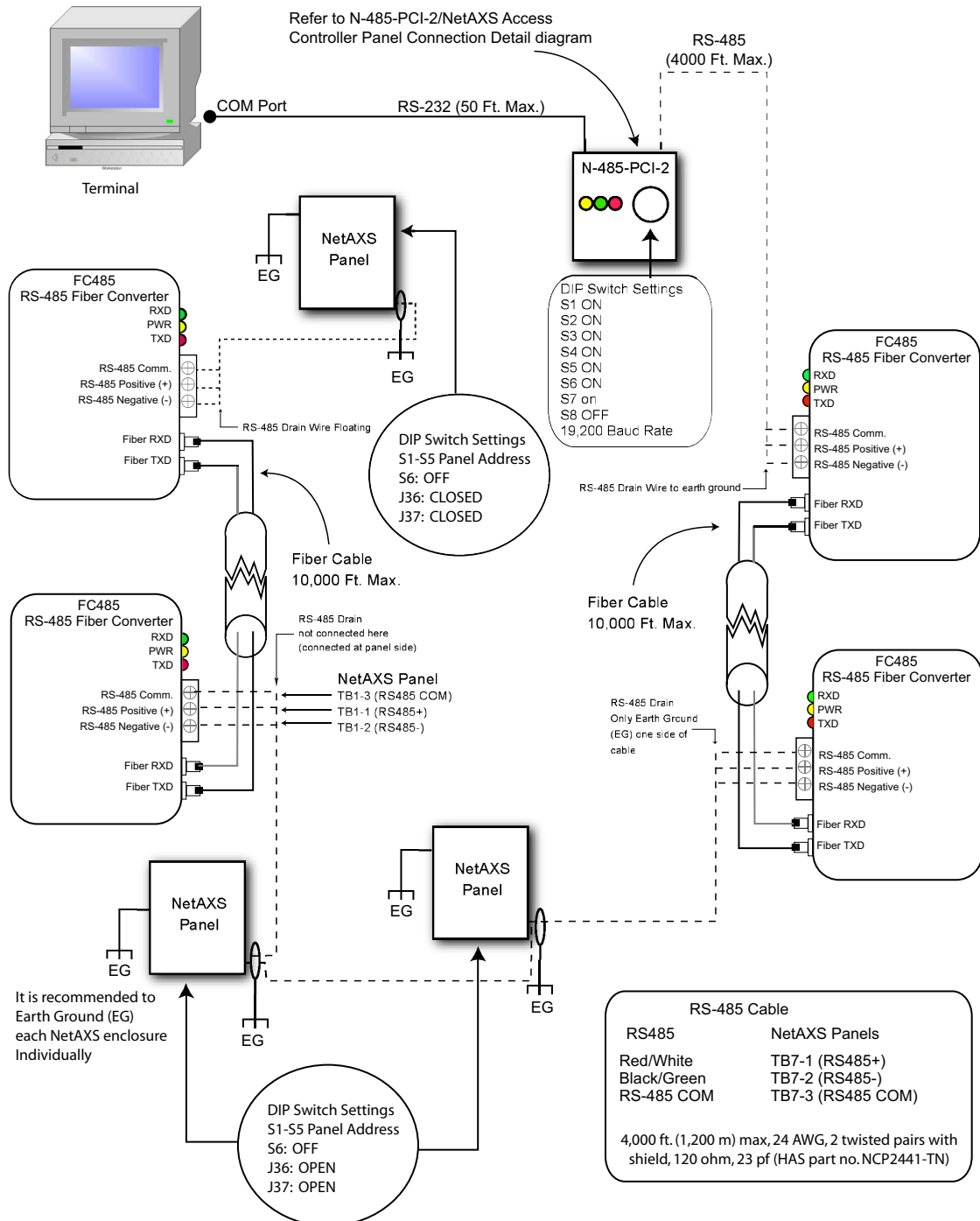

5.13 Fiber Converter to RS-485 Connection via NetAXS™

This connection supports thirty-one NetAXS™ Access Controller panels for each drop line. It has not been reviewed by UL.

Figure 29: Fiber Converter to RS-485 Connection via NetAXS™

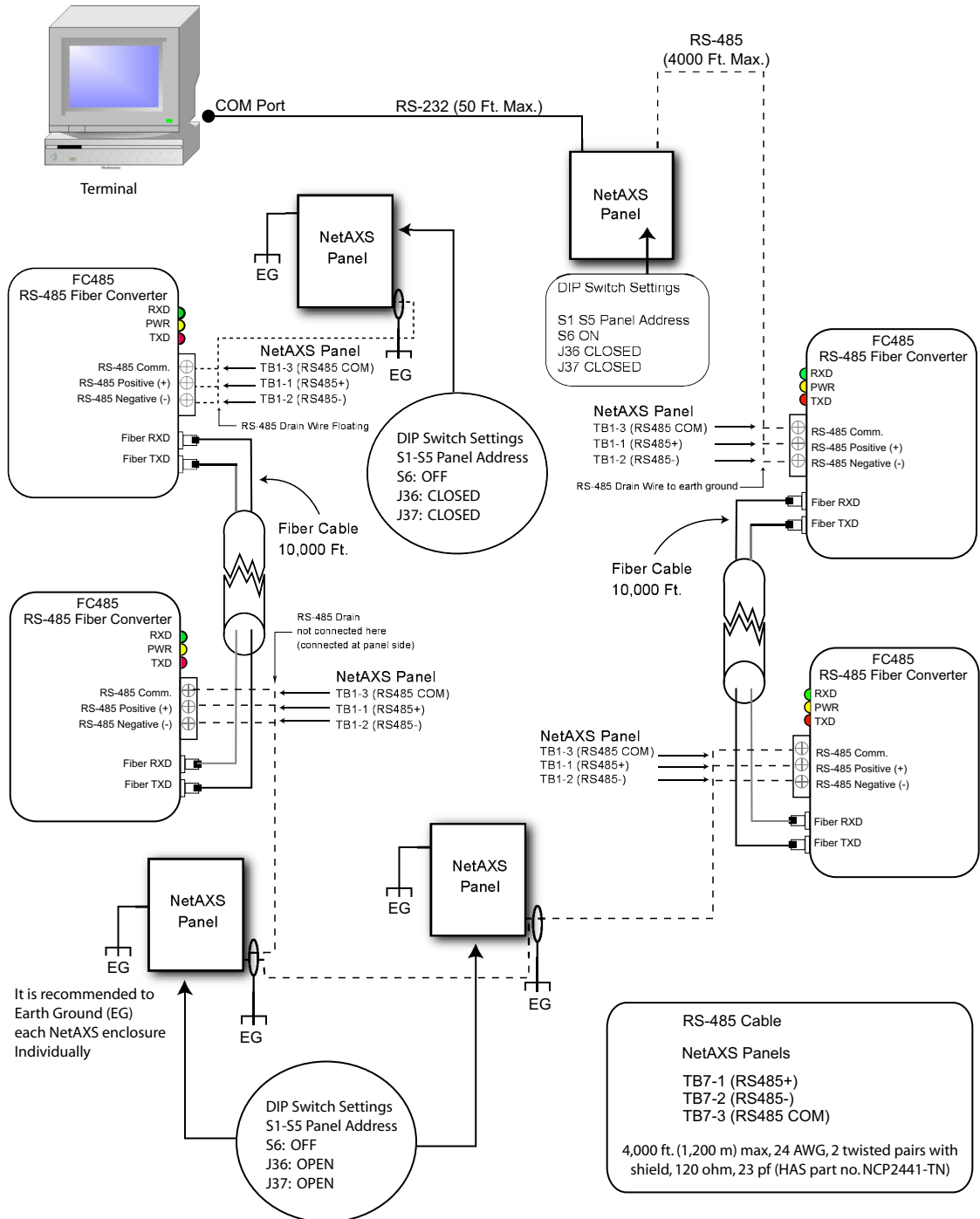

5.14 N-485-PCI-2/NetAXS™ Access Controller Panel Connection Detail

This diagram has not been reviewed by UL. Note that PCI-2 units can also be wired anywhere along the drop line. See [Figure 18](#) on page 28 and [Figure 19](#) on page 29.

Figure 30: N-485-PCI-2/NetAXS™ Access Controller Panel Connection Detail

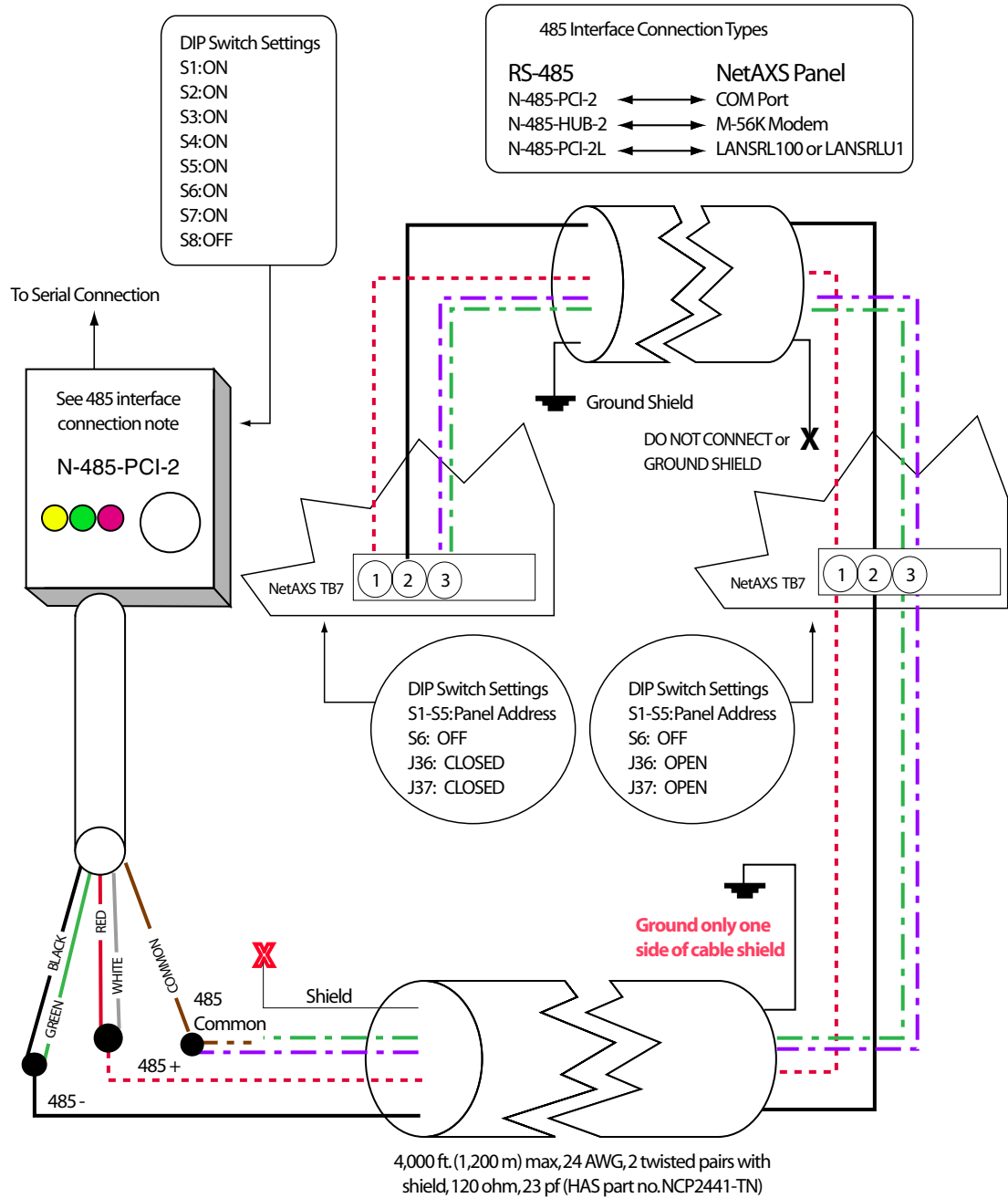

5.15 NetAXS™/NetAXS™ Access Controller Panel Connection Detail

Figure 31: NetAXS™/NetAXS™ Access Controller Panel Connection Detail

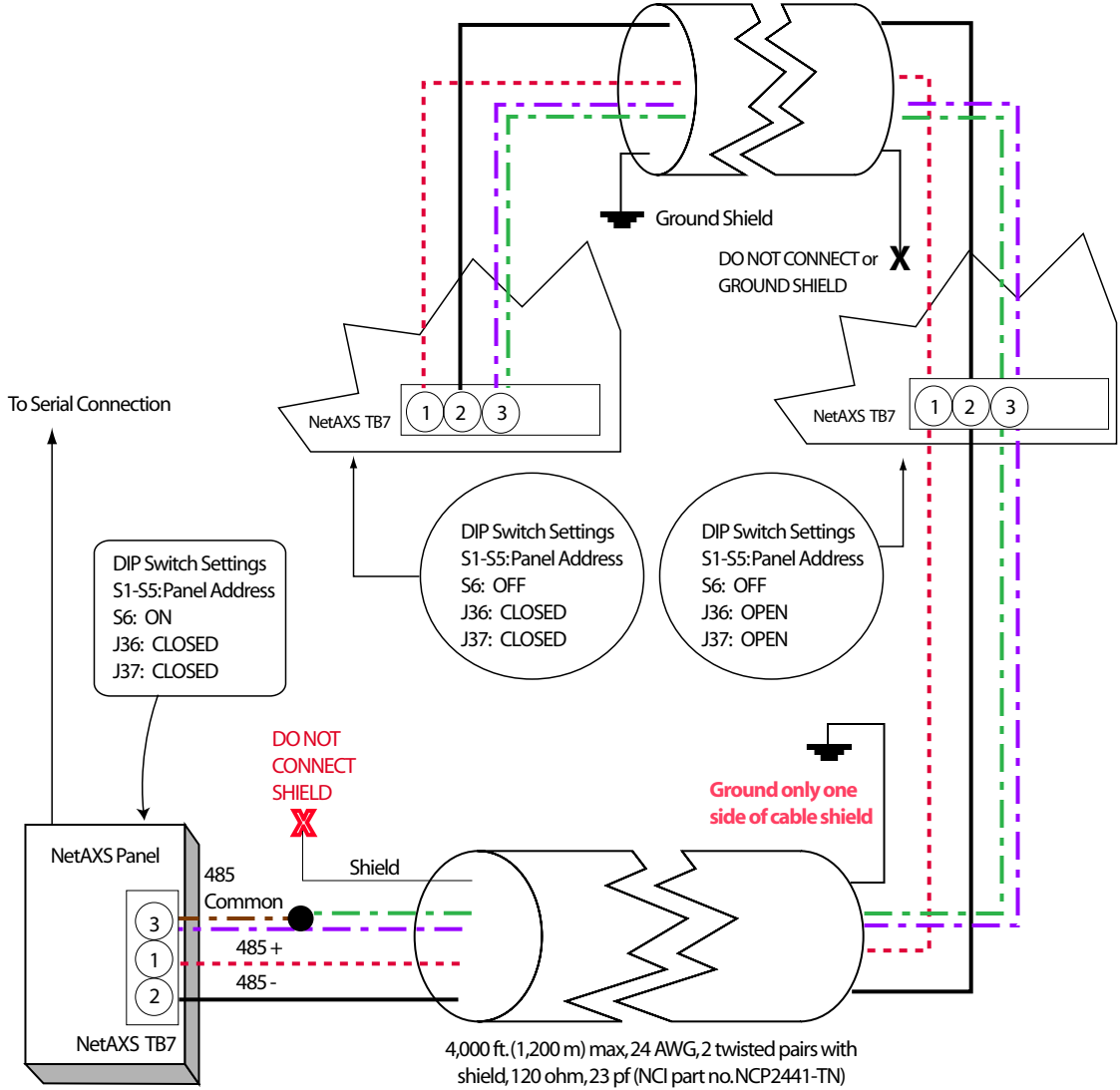

6.0 NetAXS™ Startup

6.1 LED Operation

When the panel wiring is complete, turn on the power. It might take a few minutes for the panel to complete the power-up sequence. When the board does initialize, verify that the appropriate LEDs identified in the following figure are in accord with the descriptions in [Table 5](#) on page 43.

Figure 32: System, Relay and Power LEDs

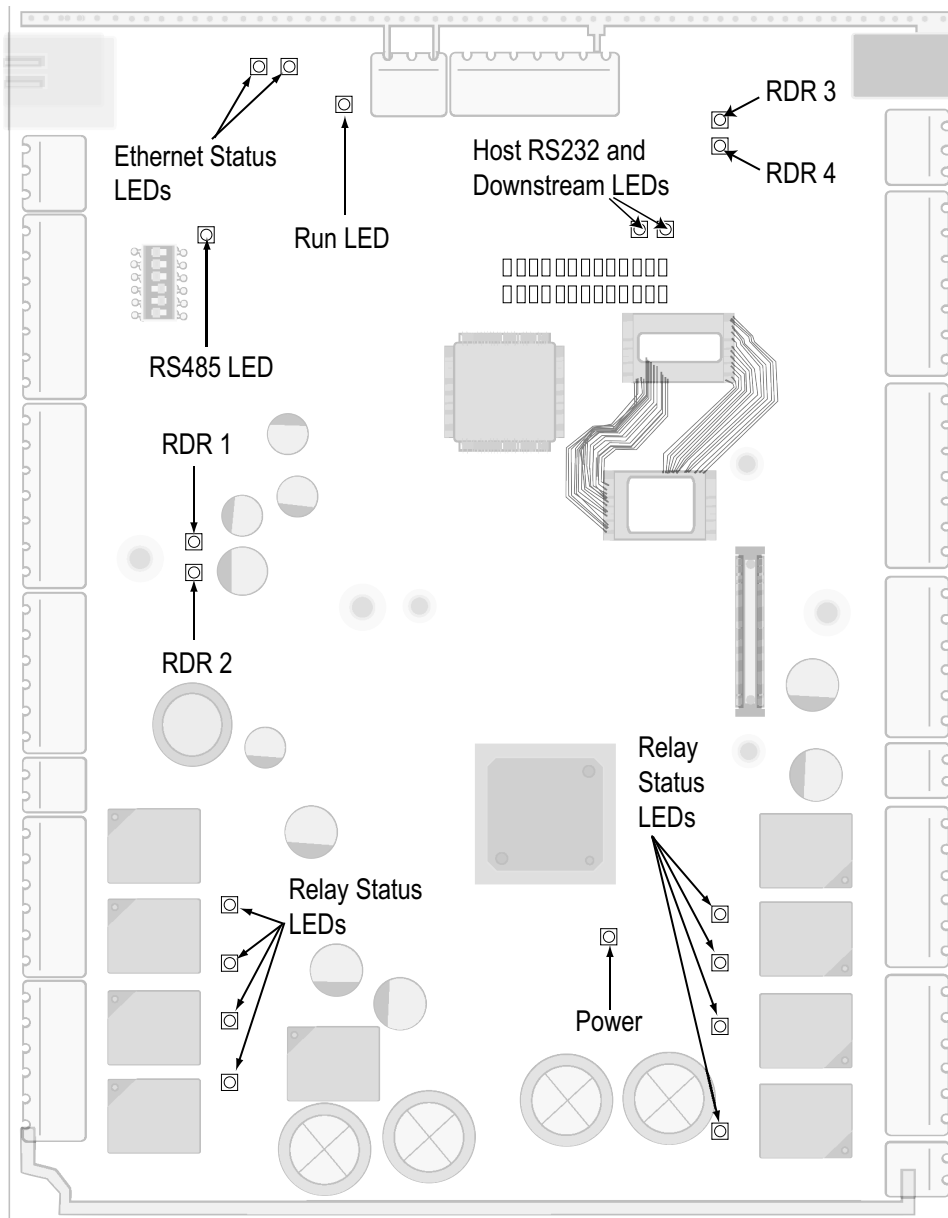

The following table indicates the status associated with each LED.

Table 5 LED Status

LED	PWR	RUN	H485	H232	DS	COM	LINK	RLY	RDR
GREEN	Power OK	Blink = normal Steady = malfunction	Multi-drop Receive Data	RS232 Receive Data	Downstream Receive Data	100Mbit	Link OK	Relay Active	Flash at read
RED	N/A	N/A	Transmit Data	Transmit Data	Transmit Data	N/A	N/A	N/A	N/A
AMBER	N/A	N/A	TX & RX Data	TX & RX Data	TX & RX Data	N/A	TX & RX Data	N/A	N/A
OFF	Power Off	Malfunction	No Com	No Com	No Com	10Mbit	No Link	Relay Off	Normal

Note: The Ethernet/COM status LED will be green even if no cable is attached.

7.0 Hardware Specifications

7.1 Relay Contacts

Four Form-C SPDT relays:

- 10 A @ 28 VDC resistive load
- 5 A @ 28 VDC inductive load

7.2 Reader Interface

- Reader Output Voltage ranges from 11.2 VDC to 12.4 VDC. The maximum Reader Output Current is 600 mA.
- Reader LED Output: Open collector driver capable of sinking up to 8 mA.
- Reader Tamper: Supervised or non-supervised input.
- Reader Data Input: TTL compatible inputs.
- Reader Buzzer Output: Open collector driver capable of sinking 8 mA at 15 VDC.

7.3 NX4S1 Wire Requirements

- Power: One twisted pair shielded, 18 AWG.
- RS-485: 24 AWG, 4,000 ft. (1,200 m) max, twisted pairs with shield, 120 ohm, 23 pf (HAS part number NC2441-TN).
- RS-232: Use cable supplied with installation kit (HAS part number CBL50). Maximum distance per COM port is 50 ft.
- Supervised Inputs: One twisted pair per input, shielded 30 ohms maximum.
- Outputs: As required by load.
- Readers: 7 conductors, 18 AWG, shielded, 500 ft. (150 m) max.

7.4 Maximum Output Loading

- Maximum current for any of the four reader outputs is 600 mA.
- Maximum current for each of the two auxiliary outputs on the NetAXS™ panel is 500 mA.
- Maximum battery charge current for the single battery is 350 mA.
- Maximum combined current of the four reader outputs and the two auxiliary outputs is 600 mA.
- Maximum combined current of the two auxiliary outputs (if used without the four reader outputs) is 500 mA.



Notes:

- Each of the eight relay output contacts on the panel is rated for either 10 A at 28 VDC (resistive) or 5 A at 28 VDC (inductive). However, they are powered from a separate power supply.
- A UL-listed system's power supply must also be UL-listed for this application.

7.5 Common Connections

Common connections are all connected internally. They are not connected to the panel chassis.

7.6 Mechanical

- Panel Dimensions
 - Width: 8 inches (203.2 mm)
 - Length: 9.75 inches (247.65 mm)
 - Height: 1.5 inches (38.1 mm)
- Panel Weight: 1.1 pounds (0.5 kg)
- Enclosure Dimension
 - Width: 14.5 inches (368.3 mm)
 - Length: 18.0 inches (457.2 mm)
 - Height: 4.4 inches (111.8 mm)
- Enclosure Weight, including 7 A-Hr battery: 22.1 pounds (10 kg)

7.7 Environment

- Temperature: 0C to 49C operating, -55C to +85C storage.
- Humidity: 5% to 85% RHNC.

7.8 Communications and Wiring

Table 6 Communications and Wiring

Communication Type	Description	Maximum Panels	Maximum Distance: Feet (Meters)
Direct to COM Port			
CBL50, RS-232 Cable	9-pin to RJ-45	1	50 (15)
N-485-PCI-2	RS-485 9-pin to CPU	31	4,000 (1,220)
Modems			
SHM-B-ASYNC/ N-485-PCI-2	Short-haul Modem to RS-485	31	5,280/4,000 (1,610/1,220)
SHM-B-ASYNC/CBL50	Short-haul Modem to RS-232	1	5,280/50 (1,610/15)
M-56K/N-485-HUB-2	Dial-up Modem to RS-485	31	NA/4,000 (NA/1,220)
Fiber			
FC485	Fiber converter to RS-485	31	10,000/4,000 (3,050/1,220)

7.9 Reader Wiring

Table 7 Reader Wiring

Cable Specifications	Description	AWG	Maximum Distance: Feet (Meters)
Readers			
NC1861-BL	6 Conductor, Shielded	18	500 (153)
Alarm Input			
NC1821-GR	Twisted Pair, Shielded	18	2,000 (610)
Relay Outputs			
NC1821-GR	Twisted Pair, Shielded	18	2,000 (610)

7.10 NX4S1 Wiring Diagram

Figure 33: NX4S1 Panel Wiring Diagram

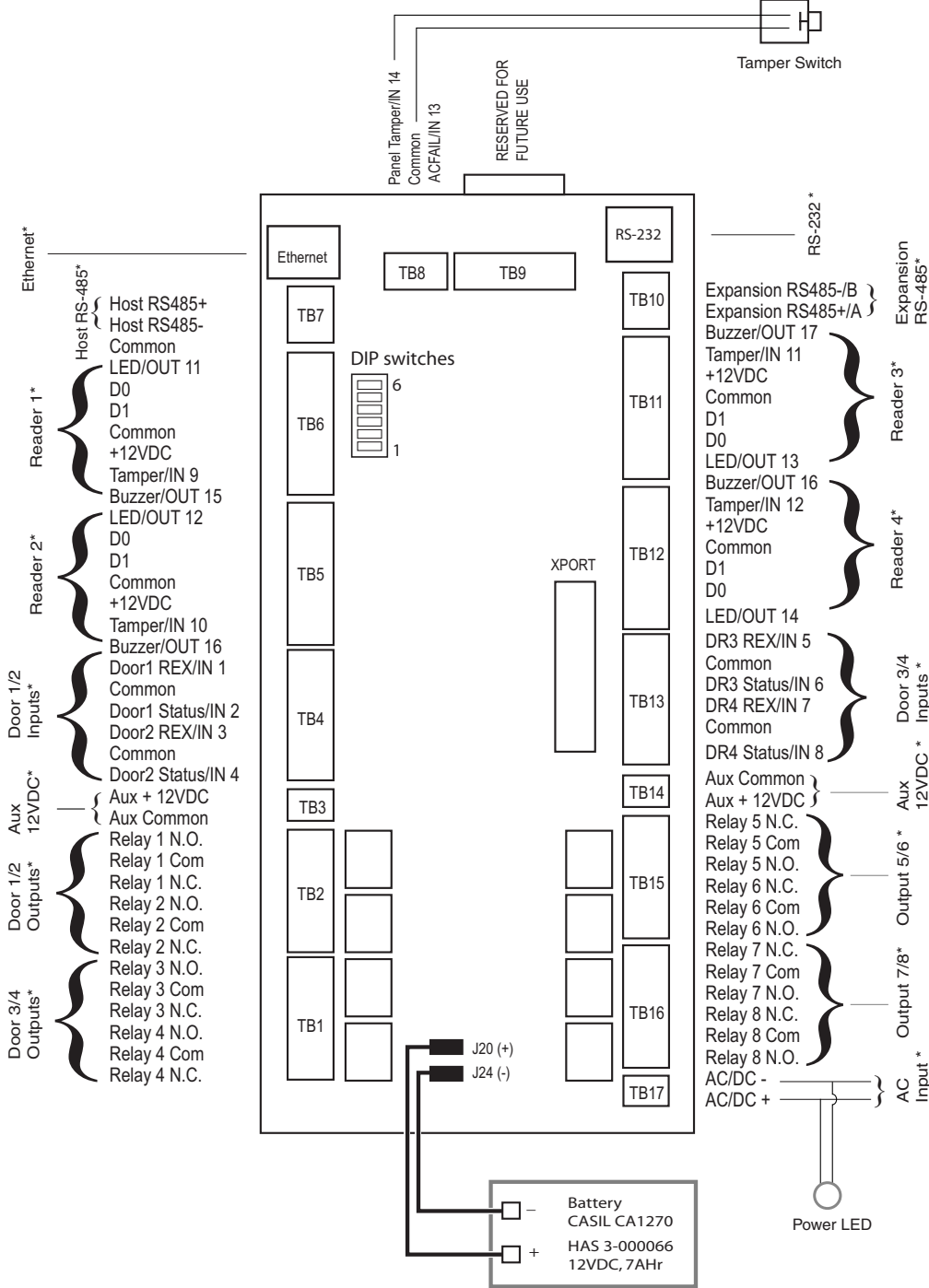

Note: Maintain at least a .25-inch distance between the non-power limited wiring (battery backup/charger wiring) and all other wiring, which is power-limited Class 2 wiring.

8.0 Maintenance

Perform the following maintenance on the NetAXS™ enclosure:

- Change the CASIL CA1270 lead-acid battery (Honeywell Access Systems part number 3-000066) every two to two and a half years.



Caution: Do not connect an uncharged battery to the panel.

- Oil the lock once per year.

9.0 Troubleshooting

Table 8 Troubleshooting Problems and Solutions

Problem	Solution
The panel powers up, but it does not respond to any communication, cards reads, or input activation.	Ensure that the Address DIP switches are set to a value other than zero. Turn off the power (including battery), change the settings, and re-apply the power.
No communications exist with the Ethernet port.	Only a panel set to be a Gateway (DIP switch 6 = ON) will have communications on the Ethernet port. If you need to use that port to access the panel, turn off the power (including the battery), change the switch setting, and reapply the power. Note that if the panel is normally not a Gateway on a Multidrop communication bus, then the Host RS-485 connection (TB7) should also be disconnected while DIP switch 6 is ON. After completion of the Ethernet session, turn off the power (including the battery), change the switch setting, re-connect the Host RS-485 terminal block, and re-apply the power.
The IP address is incorrectly set to verify the value.	If you are connecting directly to a computer instead of going through a router or hub, use a cross-over Ethernet cable.
The N1000 panels on the Multidrop bus do not report.	N1000 panels will not communicate to a NetAXS™ panel that is configured as a Gateway. Replace all of the N1000 panels with NetAXS™, or replace the Gateway panel with an N-485-PCI-2 device.
The BAD CRC counter is incrementing every minute.	Two or more panels on the Multidrop Bus have the same panel address. Verify that each panel has a unique address setting on DIP switch positions 1-5.

Table 8 Troubleshooting Problems and Solutions

Problem	Solution
A dropline panel in standalone mode using RS-232 may unexpectedly fill its buffer.	The preferred solution is to configure the standalone panel through the Web server as a Gateway and use the board PCI and AckNak communications. This also gives the user a more secure and reliable communications line. Another solution is to execute a new command that will allow the user to turn the Tesla flow control off : _U=<pn>_D (disable flow control) This prevents the panels from inadvertently filling their buffers. To turn the Tesla flow control back on: _U=<pn>_E (enable flow control)



Note: The NetAXS™ EOL network is AC-coupled. There is no resistance difference between the RS-485 positive and negative terminals if the EOL network is on or off (J36 and J37).

10.0 Technical Support

10.1 Normal Support Hours

Monday through Friday, 7:00 a.m. to 7:00 p.m. Central Standard Time (CST), except company holidays: (800) 323-4576.

10.2 Web

For technical assistance please visit <http://www.honeywellaccess.com>

NetAXS™ Standalone Operation

A

A.1 Basic Standalone Operations

A.1.1 Card Read / Door Lock Operation

1. Present a card to a reader.
2. The reader sends the card number to a reader input on the panel.
3. The panel searches its database and:
 - If it is a valid card, then energize the door relay associated with the particular reader input. The card is valid when it is in the card database on the panel and the current time and date conforms to the time zone associated with the card.
 - If it is not a valid card, the door relay remains locked.

A.1.2 Door Egress / Door Lock / Door Status Operation

1. Activate the door egress input.
2. The panel energizes the door relay associated with the particular door egress input for a default time of 10 seconds.
3. If the door status goes from close to open to close again during the 10 second door open period, the door relay will be immediately de-energized.

A.2 Standalone Settings

A.2.1 NetAXS™ Panel Hardware Settings

- Configure the system with an RS-232 connection according to [Figure 20](#) on page 30.
- Set DIP switches 1 through 5 to define the panel number (see [Table 3](#) on page 22). Panel number 0 is not valid.
- Set DIP switch 6 to the OFF position to place the panel into the Multidrop mode.
- Use a personal computer's serial communications port (COM1 or COM2) and a terminal emulation program to configure the NetAXS™ panel for normal operation.

A.2.2 Communication Settings

- Baud Rate: 115200
- Data Bits: 8
- Parity: None
- Stop Bits: 1
- Flow Control: None

A.2.3 Emulation Settings

- Echo typed characters locally: YES
- Line Delay: 500 milliseconds

A.2.4 Verifying Communications

1. Press the spacebar.
2. Press the carriage return <CR>. "S?" appear for every online panel and indicates proper communication between the terminal and panel.

A.3 Standalone Commands

Use the following commands, in the order they are listed, to configure the NetAXS™ panel.

1. T command: Sets the panel's Time
2. D command: Sets the panel's Date
3. L command: Creates Time zones for use by the cards
4. C command: Adds or Deletes cards from the panel
5. W command: Program each input for either NO/NC and Supervised or NON Supervised operation
6. P command: Sets interlocks between input points and/or output points



Note: In all examples, the underbar “_” indicates a “space” character and <CR> indicates a carriage return.

A.3.1 T (Time) Command

```
_T=pn_hh:mm<CR>
```

Variables:

pn = panel number (1-31)
hh = hours (0-23) (Military time)
mm = minutes (00-59)

Example #1:

```
_T=1_08:30<CR>
```

This command would set panel 1 to a time of 8:30 AM.

Example #2

```
_T=6_18:15<CR>
```

This command would set panel 6 to a time of 6:15 PM.

A.3.2 D (Date) Command

`_D=pn_mm/dd/yyyy_day<CR>`

Variables:

- pn = panel number (1-31)
- mm = month number (1-12)
- dd = day number (1-31)
- yyyy = year number (ex 2007, 1999, etc.)
- day = day of week (1-7):
 - 1 = Monday
 - 2 = Tuesday
 - 3 = Wednesday
 - 4 = Thursday
 - 5 = Friday
 - 6 = Saturday
 - 7 = Sunday



Note: The day of week setting is a hold-over from an old command. The panel using the mm/dd/yyyy information will automatically configure panel to the correct day of the week, regardless of the setting selected in day of week. But the command still requires a value to be entered in its place of 1-7.

Example #1:

`_D=1_01/09/2007_5<CR>`

This command would set panel 1 to a date of 1/9/2007 and to Tuesday as the day of the week.

Example #2:

`_D=25_12/14/2009_7<CR>`

This command would set panel 25 to a date of 12/14/2009 with a day of week being Monday.

A.3.3 L (Time Zone) Command

```
_L=pn_tz_h1:m1-h2:m2_days<CR>
```

Variables:

pn = panel number (1-31)
tz = time zone number (1-255)
h1 = start time zone: hours (00-23) (Military time)
m1 = start time zone: minutes (00-59)
h2 = end time zone: hours (00-23) (Military time)
m2 = end time zone: minutes (00-59)
days = days of week valid values as listed below:
1 = Monday
2 = Tuesday
3 = Wednesday
4 = Thursday
5 = Friday
6 = Saturday
7 = Sunday
0 = Holiday 1
8 = Holiday 2
9 = Holiday 3



Note: 00:00 is the earliest time possible and 23:59 is the latest time possible. A single time zone cannot be made to span mid-night, through the use of extended commands we can simulate this. For more information, please seek the guidance of technical support.

Example #1:

```
_L=5_10_08:00-17:00_1_2_3_4_5<CR>
```

This command would configure panel 5 to add a time zone entry to time zone number 10 ranging from 8AM to 5PM and would be valid during Monday, Tuesday, Wednesday, Thursday, and Friday.

Example #2:

```
_L=25_45_16:00-23:59_0_6_7_8_9<CR>
```

This command would configure panel 25 to add a time zone entry to time zone number 45 ranging from 4PM to 11:59PM and would be valid during Saturday, Sunday, Holiday, 1, 2, and 3.

A.3.4 C (Card Add) Command

```
_C=pn_code_time zone_dev<CR>
```

Variables:

pn = panel number (1-31)

code = card number (range depends on card format)

time zone = time zone number the card will follow (1-255)

dev = device numbers card will work with, see below:

1 = card reader #1

2 = card reader #2

3 = card reader #3

4 = card reader #4

Example #1:

```
_C=6_12345_10_1_2_3_4<CR>
```

This command would configure panel 6 to add a card entry of 12345 to the panels database, that will be valid on reader 1, 2, 3, and 4 during the times and days specified by time zone 10.

Example #2

```
_C=18_52989_120_1_3<CR>
```

This command would configure panel 18 to add a card entry of 52989 to the panels database, that will be valid on reader 1 and 3 during the times and days specified by time zone 120.

A.3.5 C (Card Delete) Command

```
_C=pn_code<CR>
```

Variables:

pn = panel number (1-31)

code = card number (range depends on card format)

Example #1:

```
_C=6_12345<CR>
```

This command would remove card 12345 from panel 6.

Example #2

```
_C=18_52989<CR>
```

This command would remove card 52989 from panel 18.

A.3.6 W (Input) Command

`_W=pn_input_{SO|SC|NO|NC}<CR>`

Variables:

- SO: Supervised normally open
- SC: Supervised normally closed
- NO: Non-supervised normally open
- NC: Non-supervised normally closed (default)

Example:

`_W=1_9_SO<CR>`

Input 9 has been programmed as supervised, normally open on panel 1.

A.3.7 P (Interlock) Command

`_P=pn_I/O_[number]_I/O[number]_{D|E|F|N|P}_
{D|E|F|N|P}<CR>`

Parameters:

- number: for an input number, the range is 1-96; for output, 0-78
- D: De-energize
- E: Energize
- F: Follow
- N: No action
- P: Pulse

Example:

`_P=1_I_5_O_3_E_D`

When Input 5 is triggered, Output 3 energizes.

When Input 5 returns to its normal state, Output 3 de-energizes.

A.3.8 Flow Control Disable/Enable

(Use this command only for a dropline panel using RS-232 in standalone mode)

`_U= [panel name] _{D|E}`

Parameters:

D: Disable

E: Enable

Example:

`_U=30_D`

This disables the flow control on panel 30 and prevents the panel's buffers from filling. After a hard re-set of the panel, the flow control is re-enabled.

A.4 NetAXS™ Panel Defaults

A.4.1 Reader Ports

The panel accepts a Wiegand serial data packet from the card reader. If the card is in the database, the associated relay is activated. If the card is not in the database, the relay state is unchanged.

The following are the default reader port to relay associations:

Reader Number	Controls...
1	Relay 1 (Output 1)
2	Relay 2 (Output 2)
3	Relay 3 (Output 3)
4	Relay 4 (Output 4)

A.4.2 Reader LED Outputs

The Reader LED output defaults to toggle the card reader LED from Red to Green for two seconds when a valid card is presented. No LED color change (other than a possible momentary change depending on reader used) occurs if the card is not in the database.

The following are the default reader LED port to output associations:

Reader LED	Controls...
Reader 1	Output 11
Reader 2	Output 12
Reader 3	Output 13
Reader 4	Output 14

A.4.3 Reader Tamper Inputs

The card readers have a Tamper signal wired to the NetAXS™ panel. This is a two-state input configured as a Normally Closed contact.

The following are the default Reader Tamper Input to Panel Input associations:

Tamper LED	Reports as...
Tamper 1	Input 9
Tamper 2	Input 10
Tamper 3	Input 11
Tamper 4	Input 12

A.4.4 Door Egress Inputs

The panel has a Request-To-Exit (Egress) input for each door. The default condition is a two-state input configured as Normally Closed contact. When the egress input is active, the associated output relay will be active.

The following are the default egress input associations:

Egress input	Controls relay...	Panel input	Reports as...
1	1	SP1	Input 1
2	2	SP3	Input 3
3	3	SP5	Input 5
4	4	SP7	Input 7

A.4.5 Door Status Inputs

The panel has a Door Status input for each door. The default condition is a two-state input configured as a Normally Closed contact.

The following are the default door status input associations:

Door Status input	Panel input	Reports as...
1	SP2	Input 2
1	SP4	Input 4
1	SP6	Input 6
1	SP8	Input 8

A.4.6 ACFAIL and Panel Tamper Inputs

The panel has the following two additional generic inputs that can be used as generic inputs or as either External Power Fail or Enclosure Tamper inputs. The default condition is a two-state input configured as Normally Closed. Input 14 is a special case, since it reports in as two inputs (inputs 14 and 20). Input 14 can be used as a generic input, but input 20 is used for the Enclosure Tamper alarm. An active External Power Fail input indicates that the system is operating from the battery current, not from the primary input power. An inactive External Power Fail input indicates that the system is operating from the primary input power.

Generic input	Panel input	Reports as...
Generic/External Power Fail	SP9	Input 13
Generic/Enclosure Tamper	SP10	Inputs 14 and 20

A.4.7 Additional Generic Outputs

The panel has the following four additional generic form C relay outputs that can be programmed using the P command:

Relay output	Controls...
5	Output 5
6	Output 6
7	Output 7
8	Output 8

Honeywell Access Systems
135 W. Forest Hill Avenue
Oak Creek, WI 53154
United States
800-323-4576
414-766-1798 Fax
www.honeywellaccess.com

Specifications subject to change
without notice.

© Honeywell. All rights reserved.
Document 800-00008, Revision A

Honeywell