

VISTA SERIES
VISTA-32FB
Commercial Fire and Burglary
Partitioned Security System
With Scheduling

Installation and Setup Guide

Table of Contents

General Information	ix
Programming Field Settings for UL864 Compliance	ix
SECTION 1: General Description	1-1
About the VISTA-32FB	1-1
Features	1-1
Guidelines for Wiring a System	1-3
SECTION 2: Partitioning	2-1
Theory of Partitioning	2-1
Setting-Up a Partitioned System	2-1
Common Lobby Logic	2-2
Master Keypad Setup and Operation	2-4
SECTION 3: Installing the Control	3-1
Mounting the Control in the Standard Cabinet for Commercial Fire only Applications	3-1
Mounting the Control in the Attack-Proof Cabinet (Suitable for Commercial Fire/Commercial Burglary Applications)	3-3
Installing the Keypads	3-5
Installing External Sounders	3-7
Auxiliary Relay Connections	3-10
Telephone Line Connections	3-11
Installing V-Plex Devices	3-16
Wireless Zone Expansion	3-19
Installing Output Devices	3-21
Installing a Remote Keyswitch	3-23
Installing a Remote Keypad Sounder (For Commercial Burglary use only)	3-24
Communications Device Connected to the ECP Bus	3-24
Event Log Connections	3-26
Connecting the Transformer	3-26
Earth Ground Connections	3-27
Determining the Control's Power Supply Load	3-27
Determining the Size of the Standby Battery	3-31
SECTION 4: Programming	4-1
Program Modes	4-1
Entering and Exiting Programming Mode	4-1
Data Field Programming Mode	4-1
#93 Menu Mode Programming	4-2
Zone Number Designations	4-4
Zone Response Type Definitions	4-5
Zone Input Type Definitions	4-7
Programming for ECP Communications Device	4-8
Programming for the Event Log	4-8
SECTION 5: Data Field Descriptions	5-1
About Data Field Programming	5-1
Programming Data Fields	5-1

SECTION 6: Scheduling Options.....	6-1
Time Window Definitions	6-2
Open/Close Schedules Definitions	6-3
Scheduling Menu Mode	6-4
Time Windows	6-6
Daily Open/Close Schedules	6-6
Holiday Schedules	6-7
Time-Driven Events	6-8
Limitation of Access Schedules	6-11
Temporary Schedules.....	6-12
User Scheduling Menu Mode	6-13
SECTION 7: Downloading Primer	7-1
General Information	7-1
Getting On-Line with a Control Panel	7-2
Direct-Wire Downloading	7-3
Telco Handoff.....	7-3
SECTION 8: Setting the Real-Time Clock	8-1
General Information	8-1
Setting the Time and Date	8-1
SECTION 9: User Access Code.....	9-1
General Information	9-1
User Codes and Levels of Authority	9-1
Multiple Partition Access.....	9-2
Adding a Master, Manager, or Operator Code	9-3
Changing a Master, Manager, or Operator Code	9-4
Adding an RF Key to an Existing User	9-4
Deleting a Master, Manager, or Operator Code	9-4
Exiting the User Edit Mode	9-4
SECTION 10: Testing the System.....	10-1
Battery Test.....	10-1
Dialer Test.....	10-1
Fire Drill Test (Code + [#] + 69)	10-1
One-Man Fire Walk-Test (Code + [#] + 68)	10-1
Burglary Walk-Test	10-2
Armed Burglary System Test.....	10-3
Testing Wireless Transmitters	10-3
Trouble Conditions.....	10-4
To the Installer	10-5
SECTION 11: Using the Vista-32FB as a Slave Communicator.....	11-5
Wiring.....	11-5
Programming	11-5
Sending Vista-32FB System Troubles to the Fire Alarm Panel.....	11-6
APPENDIX A: Regulatory Agency Statements	A-1
UL Installation Requirements.....	A-1
Commercial Burglary Requirements.....	A-1
UL864/NFPA Local Fire	A-1
UL864/NFPA Central Station and Remote Station Fire.....	A-1
UL609 Local Mercantile Premises/Local Mercantile Safe & Vault	A-2

UL365 Police Station Connected Burglar Alarm..... A-2
UL1610 Central Station Burglary Alarm..... A-2
APPENDIX B : Summary of System CommandsB-1
APPENDIX C: SpecificationsC-1
APPENDIX D: Contact ID Event Codes..... D-1
TABLE OF CONTACT ID EVENT CODESD-1
THE LIMITATIONS OF THIS ALARM SYSTEM
HONEYWELL LIMITED WARRANTY

List of Figures

.....

FIGURE 1-1: ISOLATING FIRE DEVICES FROM BURGLARY DEVICES.....	1-4
FIGURE 3-1: INSTALLING THE LOCK	3-1
FIGURE 3-2: SEPARATION OF CIRCUITS	3-2
FIGURE 3-3: MOUNTING THE PC BOARD.....	3-2
FIGURE 3-4: CABINET ATTACK RESISTENT CONSIDERATIONS.....	3-3
FIGURE 3-5: SEPARATION OF CIRCUITS	3-4
FIGURE 3-6: MOUNTING THE PC BOARD IN ATTACK-PROOF CABINET	3-5
FIGURE 3-7: KEYPAD CONNECTIONS TO CONTROL PANEL.....	3-5
FIGURE 3-8: ECP ISOLATOR WIRING	3-6
FIGURE 3-9: THIS FIGURE INTENTIONALLY LEFT BLANK.....	3-6
FIGURE 3-10: WIRING AUXILIARY RELAY FOR ALARM ACTIVATION	3-11
FIGURE 3-11: WIRING AUXILIARY RELAY FOR SMOKE DETECTOR RESET.....	3-11
FIGURE 3-12: 2-WIRE SMOKE DETECTOR ON ZONE 1 (FOR ZONE 2 USE TERMINALS 17 & 18).....	3-14
FIGURE 3-13: 4-WIRE SMOKE DETECTORS.....	3-15
FIGURE 3-14: WIRING LATCHING GLASSBREAKS TO ZONE 8.....	3-16
FIGURE 3-15: POLLING LOOP CONNECTIONS TO THE CONTROL PANEL	3-17
FIGURE 3-16: POLLING LOOP CONNECTIONS USING ONE 4297 EXTENDER MODULE	3-18
FIGURE 3-17: POLLING LOOP CONNECTIONS USING MULTIPLE EXTENDER MODULES	3-18
FIGURE 3-18: INSTALLING THE 5881ENHC WITH TAMPER PROTECTION.....	3-20
FIGURE 3-19: 5881/5883 RF RECEIVER (COVER REMOVED).....	3-20
FIGURE 3-20: 4204 RELAY MODULE	3-22
FIGURE 3-21: 4204CF RELAY MODULE	3-22
FIGURE 3-22: REMOTE KEYSWITCH WIRING	3-24
FIGURE 3-23: REMOTE KEYPAD SOUNDER WIRING.....	3-24
FIGURE 3-24: WIRING COMMUNICATIONS DEVICE TO KEYPAD TERMINALS	3-25
FIGURE 3-25: CONNECTING THE BACKUP BATTERIES	3-32
FIGURE 7-1: DIRECT-WIRE DOWNLOADING CONNECTIONS	7-3
FIGURE 11-1: SLAVE COMMUNICATOR WIRING DIAGRAM	11-1

Conventions Used in This Manual

Before you begin using this manual, it is important that you understand the meaning of the following symbols (icons).

UL

These notes include specific information that must be followed if you are installing this system for a UL Listed application.



These notes include information that you should be aware of before continuing with the installation, and that, if not observed, could result in operational difficulties.



This symbol indicates a critical note that could seriously affect the operation of the system, or could cause damage to the system. Please read each warning carefully. This symbol also denotes warnings about physical harm to the user.

ZONE PROG? 1 = YES 0 = NO 0

Many system options are programmed in an interactive mode by responding to alpha keypad display prompts. These prompts are shown in a single-line box.

***00**

Additional system options are programmed via data fields, which are indicated by a “star” (*) followed by the data field number.

PRODUCT MODEL NUMBERS:

Unless noted otherwise, references to specific model numbers represent Honeywell products.

UL864 (Commercial Fire) Compliance

General Information

The VISTA-32FB control panel provides features that allow the system to meet UL864 Commercial Fire requirements. To meet these requirements, follow the guidelines outlined in this section.

- The reporting of bypassed points to the central station must be enabled in Report Code Programming mode.
- Fire alarm notification circuits must be supervised (e.g., supervisory zones 970 and 971 for Bell 1 and Bell 2 outputs).
- Only one relay of the 4204CF can be programmed for a NAC. If the 4204CF relay is programmed as a NAC, the stop action must be programmed as a zone type 62, Bell 2 Timeout.
- Output devices are not intended for overriding automatic fire and building functions.
- Line cut detection must be enabled for both the main and backup phone lines (supervisory zones 974 and 975).
- Access Control Devices cannot be used.
- Audio Alarm Verification Devices cannot be used.
- Remote downloading can only be performed if a service person is at the premises.
- All supervision zones for the polling loop, RF receivers, keypads, NAC outputs, and telephone lines that are used, must be enabled as zone type 19 (24-hour trouble).

Programming Field Settings for UL864 Compliance

NOTICE TO USERS, INSTALLERS, AUTHORITIES HAVING JURISDICTION, AND OTHER INVOLVED PARTIES			
This product incorporates field-programmable software. In order for the product to comply with the requirements in the Standard for Control Units and Accessories for Fire Alarm Systems, UL 864, certain programming features or options must be limited to specific values or not used at all as indicated below.			
Program feature or option	Permitted in UL864? Y/N	Possible settings	Settings permitted in UL 864
*08 TEMPORAL SIREN PULSE	N	0 = disable 1 = enable	Not used at this time. Must be set to "0" (disable).
*13 ALARM SOUNDER (BELL) TIMEOUT	Y	Enter 01-15 multiplied by 2 minutes. 00 = no timeout.	Must be set to "3" (Minimum of 6 minutes).
*17 AC LOSS KEYPAD SOUNDING	N	0 = disable 1 = enable	Must be set to "1" (enabled).
20 VIP MODULE PHONE CODE	N	Enter 01 - 09 for the first digit; enter 11 for "" or 12 for "#" for the second digit.	Not used. Must be set to "00".
*22 KEYPAD PANIC ENABLES (PARTITION SPECIFIC)	N	0 = disable 1 = enable	Must be set to "000" for partition 1 in fire systems.
*23 MULTIPLE ALARMS (PARTITION SPECIFIC)	N	0 = disable 1 = enable	Must be set to "1" (enabled).
*26 INTELLIGENT TEST REPORTING	N	0 = disable 1 = enable	Must be set to "0" (disable).

Program feature or option	Permitted in UL864? Y/N	Possible settings	Settings permitted in UL 864
*27 TEST REPORT INTERVAL	Y	Enter 0001-9999 for the test report interval in hours. Enter 0000 for test reporting.	Must be set to "0024" (Maximum 24 hours)
*28 POWERUP IN PREVIOUS STATE	Y	0 = disable 1 = enable	Must be set to "1" (enable).
*37 DOWNLOAD COMMAND ENABLES	N	0 = disable 1 = enable	Must be set to "0" for all entries (disable).
*41 NORMALLY CLOSED OR EOLR (ZONES 3-8)	N	0 = EOLR supervision 1 = N.C. loops	Must be set to "0" (EOLR Supervision).
*42 DIAL TONE PAUSE	Y	Enter the wait time for dial tone detection: 0 = 5 seconds; 1 = 11 seconds; 2 = 30 seconds.	Must be set to "0" (5 seconds).
*44 RING DETECTION COUNT	N	Enter 00 to disable ring detection. Enter 01-14 for ring counts of 1-14. Enter 15 to select Answering Machine Defeat Mode	Must be set to "00" (disable).
*56 DYNAMIC SIGNALING DELAY	Y	Enter 00-15 times 15 seconds.	Must be set to "6" (90 seconds).
*64 - *76 (PAGER OPTIONS)	N	NA	Not Used
*77 AUTO RESTORE	Y	0 = disable 1 = restore troubles only 2 = restore troubles and fire alarms	Must be set to "1" (restore troubles only).
*80 ZONE TYPE RESTORES FOR TYPES 9, 10 & 14	N	0 = disable 1 = enable	Must be set to "1" (enable) for zone type 9.
1*12 PROGRAM NOTIFICATION SIGNAL	Y	0 = no 1 = yes	Must be set to "1" (yes).
1*13 SYSTEM SENSOR REVERSING RELAY	N	0=use neither Zone 1 or Zone 2 inputs 1=use Zone 1 input; 2=use Zone 2 input; 3=use Zone 1 and Zone 2 inputs.	Not Used. Must be set to "0".
1*18 AFFECTS LOBBY	N	0 = disable 1 = enable	Must be set to "0" (disabled) for partition 1.
1*19 ARMS LOBBY	N	0 = disable 1 = enable	Must be set to "0" (disabled) for partition 1.
1*22thru 1*25 CROSS-ZONING PAIRS (1 - 4)	N	Enter 001-032 Enter 000,000 to disable	Must be set to "000,000" (disabled) for fire zones.

Program feature or option	Permitted in UL864? Y/N	Possible settings	Settings permitted in UL 864
1*28 RF TRANSMITTER LOW BATTERY SOUND	N	0 = disarmed state only 1 = both armed and disarmed states	Must be set to "1" (both armed and disarmed states).
1*29 RF TRANSMITTER LOW BATTERY REPORTING	N	0 = disable 1 = enable	Must be set to "1" (enable).
1*30 RF RECEIVER SUPERVISION CHECK-IN INTERVAL	N	Enter 02–15 times 2 hours (4–30 hours) Enter 00 to disable receiver supervision	Maximum is 02 (4 hours) for fire installations.
1*31 RF TRANSMITTER CHECK-IN INTERVAL	N	Enter 02–15 times 2 hours (4–30 hours) Enter 00 to disable transmitter supervision	Maximum is 02 (4 hours) for fire installations.
1*35 ACCESS CONTROL DIALER ENABLES	N	0 = disable 1 = enable	Not used. Must be set to "0".
1*44 WIRELESS KEYPAD TAMPER DETECTION	N	0 = disable 1 = enable	Not used. Must be set to "0".
1*45 EXIT DELAY SOUNDING (PARTITION SPECIFIC)	N	0 = disable 1 = enable	Must be set to "0" (disable) for partition 1.
1*48 WIRELESS KEYPAD ASSIGNMENT	N	0 = none 1-2 = partition number	Not used. Must be set to "0".
1*49 SUPPRESS TX SUPERVISION SOUND	N	0 = disable 1 = enable	Must be set to "0" (disable).
1*53 DISABLE DOWNLOAD CALLBACK	N	0 = callback required 1 = no callback required	Must be set to "0" (callback required).
1*57 5800 RF BUTTON GLOBAL ARM	N	0 = disable 1 = enable	Must be set to "0" (disable).
1*58 5800 RF BUTTON FORCE ARM	N	0 = disable 1 = enable	Must be set to "0" (disable).
1*60 ZONE 5 AUDIO ALARM VERIFICATION	N	0 = disable 1 = enable	Must be set to "0" (disable).
1*72 EVENT LOG PRINTER ONLINE	N	0 = disable 1 = enable	Not used. Must be set to "0".
1*73 PRINTER BAUD RATE	N	0 = 1200 1 = 300	Not used.
1*76 CONTROL RELAY (PART-SPECIFIC)	N	01-96 = relay number 00 = relay not used.	Must be set to "00" (relay not used) for partition 1.
2*07 AUTO-DISARM DELAY (PART SPECIFIC)	N	00 = no delay. 01-14 times 4 minutes (04-56) delay. 15 = no auto disarming.	Must be set to "15" (no auto disarming) for partition 1.

Program feature or option	Permitted in UL864? Y/N	Possible settings	Settings permitted in UL 864
2*18 ENABLE GOTO FOR THIS PARTITION (partition-specific)	N	0 = disable 1 = enable	Must be set to "0" (disable) for partition 1.
2*21 SUPERVISION PULSES FOR COMMUNICATIONS DEVICE	N	0 = disable 1 = enable	Not used. Must be set to "00000" (disable).
2*22 DISPLAY FIRE ALARMS OF OTHER PARTITIONS	N	0 = disable 1 = enable	Must be set to "0" (disable) for partition 1.
2*23 DISPLAY BURG, PANIC AND CO ALARMS FOR OTHER PARTITIONS	N	0 = disable 1 = enable	Must be set to "0" (disable) for partition 1.
2*24 DISPLAY TROUBLES OF OTHER PARTITIONS	N	0 = disable 1 = enable	Must be set to "0" (disable) for partition 1.
3*01 EVENTS DISPLAY LOCK	N	0 = disable 1 = enable	Must be set to "1" (enable).
3*12 ZN TYPE 18 DELAY USE	N	0 = disable 1 = enable	Must be set to "0" (disable).
3*13 FIRE SUPERVISORY RESPONSE TO OPEN/SHORT (APPLIES TO ZONE TYPE 18)	N	0 = Trouble on open/Supv on short 1 = Supv on open/Supv on short	Must be set to "0".
3*14 WATERFLOW ALARM SILENCE OPTION	N	0 = Silenced by User Code + OFF 1 = Silenced when zone restores	Must be set to "0" (Silenced by User Code + OFF).
3*16 DELAY FOR ZONE TYPES 17 & 18 (Waterflow/Supervisory)	N	Enter 01-15 times 2 seconds Enter 00 for no delay	Must be set to 00 (no delay).
3*18 EXTENDED DELAY FOR ZONE TYPES 17 & 18 Multiplies delay in 3*16 x 4)	N	0 = no extended delay 1 = multiply delay by 4	Must be set to 0 (no extended delay).
3*19 AUXILIARY INPUT ALTERNATE FUNCTION ENABLE	N	0 = disable 1 = enable	Must be set to 0 (disable).
3*20 TRIGGER OUTPUTS FUNCTION SELECTION	N	0 = remote keypad sounder 1 = keyswitch LEDs	Must be set to 0 (remote keypad sounder).
3*21 MAXIMUM NUMBER OF DIALER ATEMPTS	Y	1-8	Must be set at 3, 4 or 5.

Program feature or option	Permitted in UL864? Y/N	Possible settings	Settings permitted in UL 864
3*50 ZONE TYPE RESTORE ENABLES FOR TYPES 16-18	N	0 = disable 1 = enable	Must be set to "1" (enable).
3*59 ENABLE BELL 2 & AUXILIARY RELAY CHIME ANNUNCIATION	N	0 = disable 1 = enable	Must be set to "0" (disable) if Bell 2 or Aux Relay is used for Fire.
3*60 BELL 2 & AUX RELAY TIMEOUT	Y	Enter 01-15 multiplied by 2 minutes. 00 = no timeout.	Must be set to "3" (Minimum of 6 minutes).
3*82 BURGLARY FEATURES ON PARTITION 1 ENABLE	N	0 = disable 1 = enable	Must be set to "0" (disable).
RESTRICTION FOR FIRE RELAYS	Y	Yes No	Restriction for # 70 must be set to Yes when programming fire relays.

General Description

About the VISTA-32FB

The VISTA-32FB is a two-partition, UL Listed Commercial Fire and Burglary control panel. The Control can also be used as a slave communicator in conjunction with an external fire alarm panel: For use as a slave communicator, refer to Section 11 of this manual. Unless otherwise indicated, all other information in this manual describes the control panel as a Commercial Fire/Burglary detection system.

Features

Hardwire and Optional Expansion Zones

- Provides eight hardwire zones.
- Supports up to 16 2-wire smoke detectors each on zone 1 and zone 2 (32 total).
- Triggers the built-in sounders on other hardwired smoke detectors if one smoke detector annunciates an alarm.
- Supports up to 50 2-wire latching glassbreak detectors on zone 8.
- Supports up to 24 additional expansion zones using a built-in polling (multiplex) loop.
- Supports up to 32 wireless zones fewer if using hardwire and/or polling loop zones.
- Provides three keypad panic keys: 1 + * (A), * + # (B), and 3 + # (C).

Peripherals Devices

- Supports up to 31 addressable devices, (keypads, RF receivers, relay modules, etc.).
- Supervises devices (keypads, RF receivers, and relay modules) and individual relays (up to 32), as well as system zones (RF receivers and keypad panics).
- Provides 96 outputs using 4204 and 4204CF Relay Modules, and V-Plex Relay Modules can activate outputs in response to system events (alarm condition), at a specific time of day, at random times, and manually using the #70 Relay Command Mode.
- Supports one additional style-Y supervised Notification Appliance Circuits using a 4204CF.
- Supports the ADEMCO 4146 Keyswitch on either of the system's two partitions.

Arming/Disarming and Bypassing

- Provides global arming capability (ability to arm all partitions the user code has access to in one command).
- Supports Exit Error Logic, whereby the system can tell the difference between a regular alarm and an alarm caused by leaving an entry/exit door open. If the system is not subsequently disarmed, faulted entry/exit zone(s) and/or interior zones are bypassed and the system arms.
- Supports Recent Close report, which is designed to notify the central station that an alarm has occurred within 2 minutes after the exit delay has expired.

Partitioning

- Can control two separate areas (partitions) independently, each functioning as if it had its own separate control. All fire zones must be assigned to partition 1.
- Provides a Common Lobby partition, which can be programmed to arm automatically when the other partition is armed, and to disarm when the other partition is disarmed.
- Provides a Master partition (3) used for the purpose of viewing the status of all partitions at the same time.
- Can display fire, burglary, panic, and trouble conditions at all other partitions' keypads (selectable option).

Scheduling

- Can automate system functions, such as arming, disarming, and activation of outputs (e.g., lights).
- Provides an End User Output Programming Mode, allowing the user to control outputs.

System Communication

- Provides supervision of the phone lines (main and backup)
- Supports the 5140DLM optional backup dialer for the second phone line.
- Supports ADEMCO Contact ID; ADEMCO High Speed; ADEMCO Express; and 3+1, 4+1, and 4+2 ADEMCO and SESCOA/Radionics Low-Speed formats.



The system is shipped defaulted for Contact ID communication. It is the only format capable of uniquely reporting all 32 zones, as well as openings and closings for all 75 users. This requires central stations to be equipped with the MX8000 receiver fully support all new VISTA-32FB report codes. If you need to update your MX8000 receiver, contact your distributor.

- Provides the Dialer Queue Report in the event of a loss of communications between the dialer and the central station, i.e. telco loss. The total events that will be queued up is 128 (91 Burg + 37 Life Safety). A Dialer Queue Overflow report (E354) will be sent if the report queue goes beyond its limits. Note that: Life Safety includes Fire, CO, 24 HR Silent/Audible/Auxiliary, and Duress. Life Safety events may go beyond 37 (up to 128) if there are no Burg events in the queue. If all dialer attempts are exhausted before communication to the central station is restored, the queue will be cleared.

Downloading

- Supports upload and download capability. (Downloading must be site-initiated for Commercial Fire installations.)
-

UL

Downloading is not listed for use in UL installations.

Event Log

- Provides an event log (history log) that can store up to 512 events.
- Can view the event log on an alpha keypad.

Fire Walk-Test Mode

- Provides an automatic test of integrated V-Plex devices that have the automatic test feature.
- Can display all fire zones that remain untested.
- Can log test results in the event log.
- Can report the test results to the central station.

Additional Features

- Provides two style-Y supervised Special Application Notification Appliance Circuits.
 - Provides an auxiliary relay (form C) that can activate alarms troubles/supervisories, reset 4-wire smoke detectors, or as a battery saver (removes power from non-critical loads 4 hours after AC power loss).
 - Provides up to 60 installer-defined, custom words that can be used for zone descriptors.
 - Provides 32 keypad macro commands (each macro is a series of keypad commands of up to 32 keystrokes) using the A, B, C, and D keys by partition.
 - Provides cross-zone capability, which helps prevent false alarms by preventing a zone from going into alarm unless its cross-zone is also faulted within a 5-minute period.
 - Contains a built-in User Manual, which provides the end user with a brief explanation of the function of a key when the user presses any of the function keys on the keypad for 5 seconds.
 - Provides trigger outputs, which may interface with Communications Devices or other devices such as keyswitch LEDs, or printer.
 - Provides Maintenance Signal support for certain smoke detectors (5192SD, 5192SDT, 5193SD, and 5193SDT).
-



At least one 2-line alpha keypad (6160/6160CR-2) must be connected to the system for programming (if you are using keypad programming), and must remain connected to the system in order to allow the primary user to program additional user codes into the system at a later time.

Guidelines for Wiring a System

The installer must keep certain guidelines in mind while installing a system. The Vista-32FB contains an ECP bus and a polling loop bus for connecting Fire and Burglary devices. When installing a Fire ONLY system or Burglary ONLY system both busses may be used interchangeably. When installing a Commercial Fire and Burglary System all Fire devices must be isolated from the Burglary devices. This is accomplished by using an isolator as shown in Figure 1-1. Additionally, in Commercial Fire installations, the primary keypad must be connected to Keypad Port 2 (J4) mounted within 20 feet of the control panel, and wired in conduit.

A fault on an SLC may disable all NACs on that circuit therefore only one NAC per SLC circuit may be used. Synchronization is based on the individual zone output basis only, not between each sync module. There is no synchronization between the individual sync modules.

Notification Appliance Circuit (NAC) must be wired and isolated or Riser Conductors must be installed in accordance with the survivability from attack by fire requirements in the National Fire Alarm Code, NFPA 72.

ISOLATION OF FIRE AND BURGLARY DEVICES ON THE POLLING LOOP

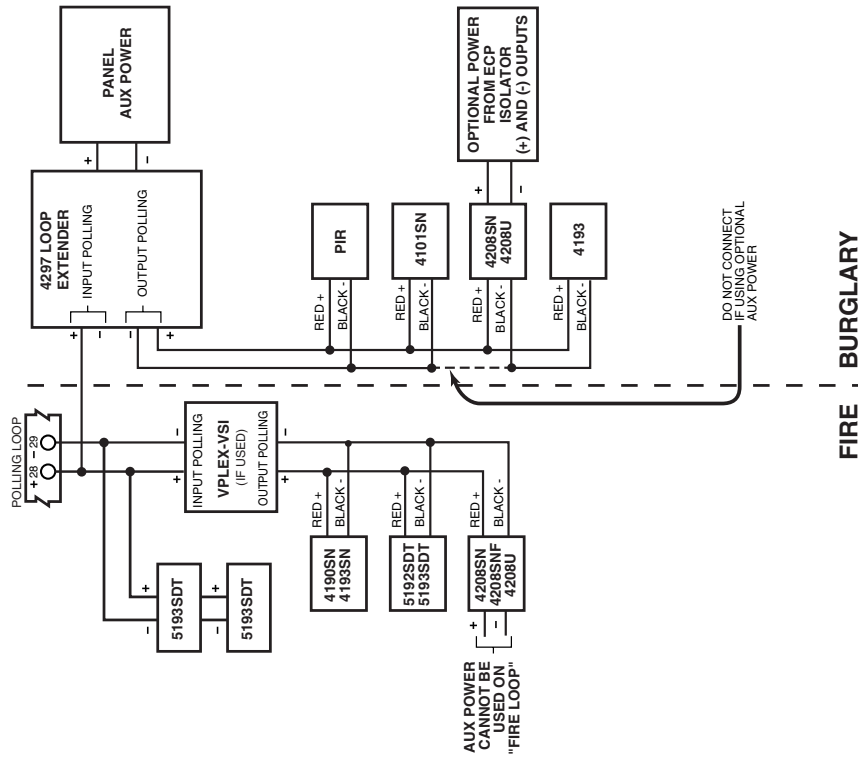

V32FEB-001-V0

ISOLATION OF FIRE AND BURGLARY DEVICES ON THE ECP BUS

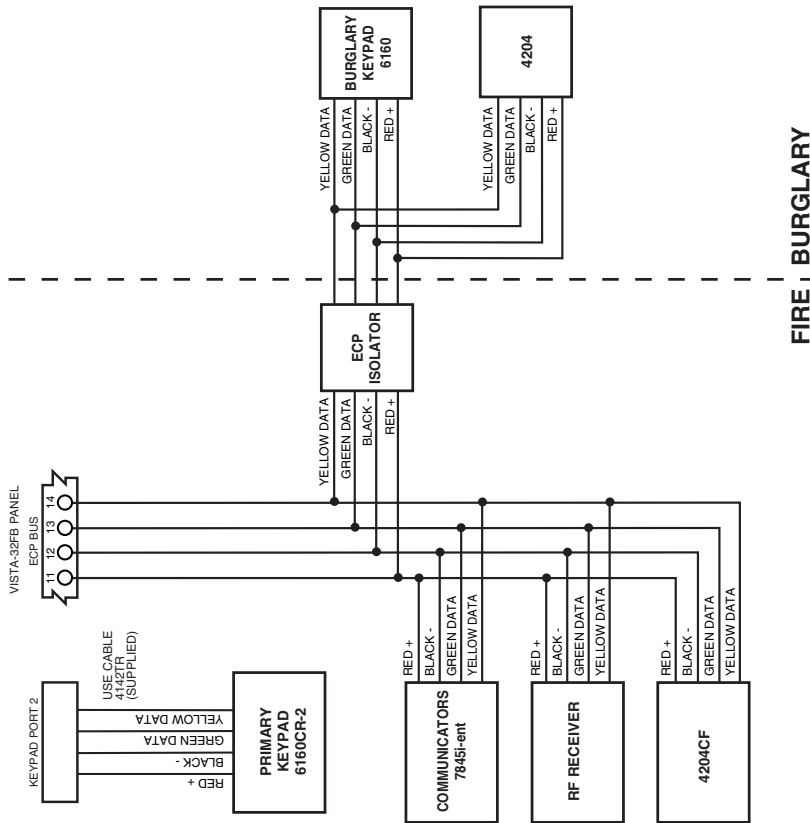

- NOTES:**
1. FOR CLARITY OF THIS DRAWING THE ECP BUS IS SHOWN USING A T-TAP FOR MODULE CONNECTION. ACTUAL T-TAP CONNECTIONS MUST BE CONTAINED WITHIN THE ENCLOSURE.
 2. WHEN USING A 4297 FOR ISOLATION, ISOLATED DEVICES MUST BE EITHER ALL FIRE OR ALL BURGLARY. NO COMBINATION OF FIRE/BURGLARY DEVICES IS PERMITTED.
 3. POLLING LOOP TERMINAL 29 CAN BE USED FOR POLLING LOOP DEVICES THAT ARE USING ONLY 2-WIRE CONNECTIONS.

Figure 1-1: Isolating Fire Devices from Burglary Devices

Partitioning

Theory of Partitioning

This system provides the ability to arm and disarm up to two different areas, as if each had its own control. These areas are called partitions. A Partitioned system allows the user to disarm certain areas while leaving other areas armed, or to limit access to certain areas to specific individuals. Each system user can be assigned to operate any or all partitions, and can be given a different authority level in each.

Before anything can be assigned to those partitions, you must first determine how many partitions (1-2) are required. Following are some facts you need to know about partitioning.

Keypads

Each keypad must be given a unique "address" and be assigned to one partition. It can also be assigned to Partition 3 if Master keypad operation is desired. (See "Master Keypad Setup and Operation" paragraph later in this section.)

UL In Commercial Fire installations, field 2*18 (Log on from other partitions) must be disabled for partition 1

Zones

Each zone must be assigned to one partition. The zones assigned to a partition will be displayed on that partition's keypad(s).

UL All fire zones must be assigned to partition 1 to ensure that all Fire Test modes operate correctly.

Users

Each user may be given access to one or more partitions. If a user is to operate more than one partition and would like to arm/disarm all or some of those partitions with a single command, the user must be enabled for Global Arming for those partitions (when entering user codes).

A user with access to more than one partition (multiple access) can "log on" to one partition from another partition's keypad, provided that program field 2*18: Enable GOTO is enabled for each partition he/she wants to log on to from another.

A partition can be selected as a "common lobby" partition, and other partitions can affect this partition by causing arming/disarming of this partition to be automated (see "Common Lobby Logic" later in this section).

Setting-Up a Partitioned System

The basic steps to setting up a partitioned system are described below. If you need more information on how to program the options, see *SECTION 4: Programming*.

1. Determine how many partitions the system will consist of (programmed in field 2*00).
2. Assign keypads to partitions (*Device Programming* in the #93 Menu Mode).
3. Assign zones to partitions (*Zone Programming* in the #93 Menu Mode).
4. Confirm zones are displayed at the keypad(s) assigned to those partitions.
5. Assign users to partitions.
6. Enable the GOTO feature (program field 2*18) for each partition a multiple-access user can log on to (alpha keypad only).
7. Program partition-specific fields (see the *SECTION 5: Data Field Descriptions*).

Common Lobby Logic

When an installation consists of a partition shared by users of other partitions in a building, that shared partition may be assigned as the "common lobby" partition for the system (program field 1*17). An example of this might be in a medical building where there are two doctors' offices and a common entrance area (see example that follows explanation).

The Common Lobby feature employs logic for automatic arming and disarming of the common lobby. Two programming fields determine the way the common lobby will react relative to the status of other partitions. They are: 1*18 Affects Lobby and 1*19 Arms Lobby.

1*18 Affects Lobby (must be programmed by partition)

Setting this field to 1 for a specific partition causes that partition to affect the operation of the common lobby as follows:

- a. When the first partition that affects the lobby is disarmed, the lobby is automatically disarmed.
- b. The common lobby cannot be armed unless every partition selected to affect the lobby is armed.

1*19 Arms Lobby (must be programmed by partition)

Setting this field to 1 for a specific partition causes that partition to affect the operation of the common lobby as follows:

- a. The common lobby cannot be armed unless every partition selected to affect the lobby is armed.
- b. Arming a partition that is programmed to arm the lobby causes the system to automatically attempt to arm the lobby. If any faults exist in the lobby partition, or if another partition that affects the lobby is disarmed, the lobby cannot be armed, and the message "UNABLE TO ARM LOBBY PARTITION" is displayed.



You cannot select a partition to "arm" the lobby unless it has first been selected to "affect" the lobby. Do not enable field 1*19 without enabling field 1*18.

The following chart sums up how the common lobby partition will operate.

1*18 Affects Lobby	1*19 Arms Lobby	Disarms when partition disarms?	Attempts to arm when partition arms?	Can be armed if other partitions disarmed?
0	0	NO	NO	YES
1	0	YES	NO	NO
1	1	YES	YES	NO
0	1	---ENTRY NOT ALLOWED---		

Example

Here is an example of how the lobby would react in a typical setup.

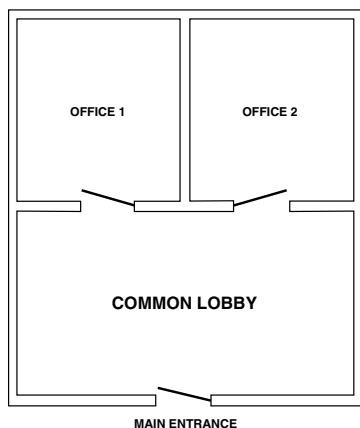

User #1 has access to Office #1 and the Common Lobby.
 User #2 has access to Office #2 and the Common Lobby.
 Office #1 is set up to affect the Common Lobby, but not arm it.
 Office #2 is set up to affect and arm the Common Lobby.

NOTE: In the tables below, the notations in parentheses () indicate the current status of the other partition when the user takes action.

Sequence #1:

	Office 1	Office 2	Lobby Action
User #1:	Disarms	(Armed)	Disarms
User #2:	(Disarmed)	Disarms	No Change
User #1:	Arms	(Disarmed)	No change
User #2:	(Armed)	Arms	Arms

Sequence #2:

	Office 1	Office 2	Lobby Action
User #2:	(Armed)	Disarms	Disarms
User #1:	Disarms	(Disarmed)	(No change)
User #2:	(Disarmed)	Arms	No Change
User #1:	Arms	(Armed)	No Change

Notice that in sequence #1, because Office #2 was the last to arm, the lobby also armed (Office #2 is programmed to affect and arm the lobby). In sequence #2, the lobby could not arm when Office #2 armed, because Office #1, which affects the lobby, was still disarmed.

When Office #1 armed, the lobby still did not arm because Office #1 was not programmed to arm the lobby. User #1 would have to arm the lobby manually. Therefore, you would want to program a partition to affect and arm the lobby if the users of that partition are expected to be the last to leave the building.

UL Do not assign partition 1 as the common lobby if fire zones are being used in the system. All fire zones must be assigned to partition 1 to ensure all Fire Test modes operate correctly.

How User Access Codes Affect the Common Lobby**Codes with Global Arming**

If a code is given "global arming" when it is defined (see *SECTION 9: User Access Codes*), the keypad prompts the user to select the partitions they want to arm. Only the partitions the user has access to are displayed. This allows the user to choose the partitions to be armed or disarmed, and so eliminates the "automatic" operation of the lobby. Keep in mind, however, that if a user attempts to arm all, and another "affecting" partition is disarmed, the user cannot arm the lobby, and the message "UNABLE TO ARM LOBBY PARTITION" is displayed.

Codes with Non-Global Arming

If a user arms with a non-global code, the lobby partition operation is automatic, as described by fields 1*18 and 1*19.

Other Methods of Arming/Disarming

Common Lobby logic remains active when arming or disarming a partition that affects and/or arms the common lobby in one of the following manners:

- Quick-Arm
- Keyswitch
- Wireless Button
- Wireless Keypad

Arming/Disarming Remotely

If a user arms or disarms remotely (through Compass downloading software) the lobby does not automatically follow another partition that is programmed to arm or disarm the lobby. The lobby must be armed separately, after arming all affecting partitions first.

Auto-Arming/Disarming

If scheduling is used to automatically arm and/or disarm partitions, the common lobby partition does not automatically follow another partition that is programmed to arm or disarm the lobby. The lobby partition must be scheduled to arm/disarm and must be scheduled as the last partition to arm.



If you are using auto-arming, make sure that the **Auto-Arm Delay** and **Auto-Arm Warning** periods, for the lobby partition, (fields 2*05 and 2*06) combined are longer than that of any other partition that affects the lobby. This causes the lobby to arm last.

Master Keypad Setup and Operation

Although this system has two actual partitions, it provides an extra partition strictly for the purpose of assigning keypads as Master keypads for the system.

Assigning any keypad to Partition 3 in *Device Programming* in the #93 *Menu Mode* makes that keypad a Master keypad. A Master keypad reflects the status of the entire system (Partitions 1-2) on its display at one time. This is useful because it eliminates the need for a building security officer to have to log on to various partitions from one partition's keypad to find out where an alarm has occurred.

UL In Commercial Fire installations, field 2*18 (Log on from other partitions) must be disabled for partition 1.

The following is a typical display:

```
SYSTEM 12
STATUS R*
```

Possible status indications include:

A = Armed Away	S = Armed Stay	M = Armed Maximum	C = Comm Fail
I = Armed Instant	R = Ready	N = Not Ready	
B = Bypassed/Ready	* = Alarm	T = Trouble	
F = Fire Alarm	P = AC Power Failure	L = Low System Battery	

To obtain more information regarding a particular partition, enter [*] + Partition No. (e.g., [*] + [2]). This allows viewing only of that partition. In order to affect that partition, the user must use a code that has access to that partition. Also, in order for a user of any partition to log on to Partition 3 to view the status of all partitions, that user must have access to all partitions. Otherwise, access is denied.

The following is displayed for a fault condition on Zone 2 (Loading Dock Window) on Partition 1 (Warehouse) when a user logs on from a keypad on Partition 3:

```
WHSE DISARMED
HIT * FOR FAULTS
```

Pressing [*] causes the following display to appear at Partition 1's keypad(s):

```
FAULT 002 LOADING
DOCK WINDOW
```

Additional zone faults are displayed one at a time. To display a new partition's status, press [*] + Partition No.

The Armed LED on a Master keypad is lit only if all partitions have been armed successfully. The Ready LED is lit only if all partitions are "ready to arm." Neither LED is lit if only some partitions are armed and/or only some partitions are ready.

Press [*] + [0] or [*] + [3] to return to the master partition. Otherwise, if no keys are pressed for 2 minutes, the system automatically returns to the master partition.

The sounder on a Master keypad reflects the sound of the most critical condition on all of the partitions. The priority of the sounds, from most critical to least critical, is as follows:

1. Pulsing fire alarm sounds
2. Steady burglar alarm sounds
3. Trouble sounds (rapid beeping)

Silence the sounder by pressing any key on the Master keypad or a keypad on the partition where the condition exists.



A Master keypad uses the same panics as Partition 1. Master keypad panics are sent to Partition 1, and will activate on Partition 1. Therefore, panics must be programmed for Partition 1.

Installing the Control

This section describes the procedures for mounting and wiring the control panel and all the peripheral devices. The control panel comes in two cabinet configurations; one for Commercial Fire only and one for Commercial Fire and Commercial Burglary with cabinet attack resistance considerations.

Mounting the Control in the Standard Cabinet for Commercial Fire only Applications

If you are installing a Vista-32FB in the Fire-only cabinet with the internally-mounted transformer, follow the steps below.

Step	Action
1	Before mounting the circuit board, remove the metal knockouts for the wiring entry that you will be using. DO NOT ATTEMPT TO REMOVE THE KNOCKOUTS AFTER THE CIRCUIT BOARD HAS BEEN INSTALLED.
2	Using fasteners or anchors (not supplied), mount the control cabinet to a sturdy wall in a clean, dry area that is not readily accessible to the general public. The back of the cabinet has four holes for this purpose.

Installing the Cabinet Lock

To install the lock, perform the following steps:

Step	Action
1	Remove the cabinet door, and the lock knockout from the door. Insert the key into the lock (see Figure 3-1).
2	Position the lock in the hole, making certain that the latch will make contact with the latch bracket when the door is closed.
3	When correctly positioned, push the lock until its snap tabs hold it securely.

Use a Honeywell No. K4445 Lock (supplied).

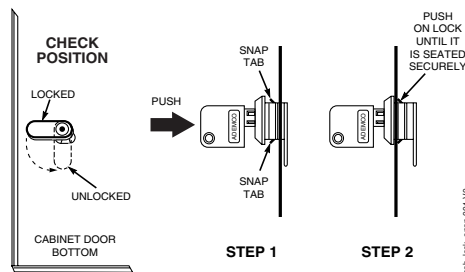

Figure 3-1: Installing the Lock

Commercial Fire Guidelines

For Commercial Fire installations, the following requirements apply (See Figure 3-2).

- System components mounted inside the cabinet must be placed so that all power-limited wiring is separated from all non-power-limited wiring (AC and battery) by a minimum of ¼-inch (6.4mm).
- Non-power-limited wiring that exits the control panel (i.e., transformer wiring) must be run in conduit.
- All unused knockouts must be plugged.
- All wiring that exits the control panel must be strain-relieved (e.g., tie-wrapped).

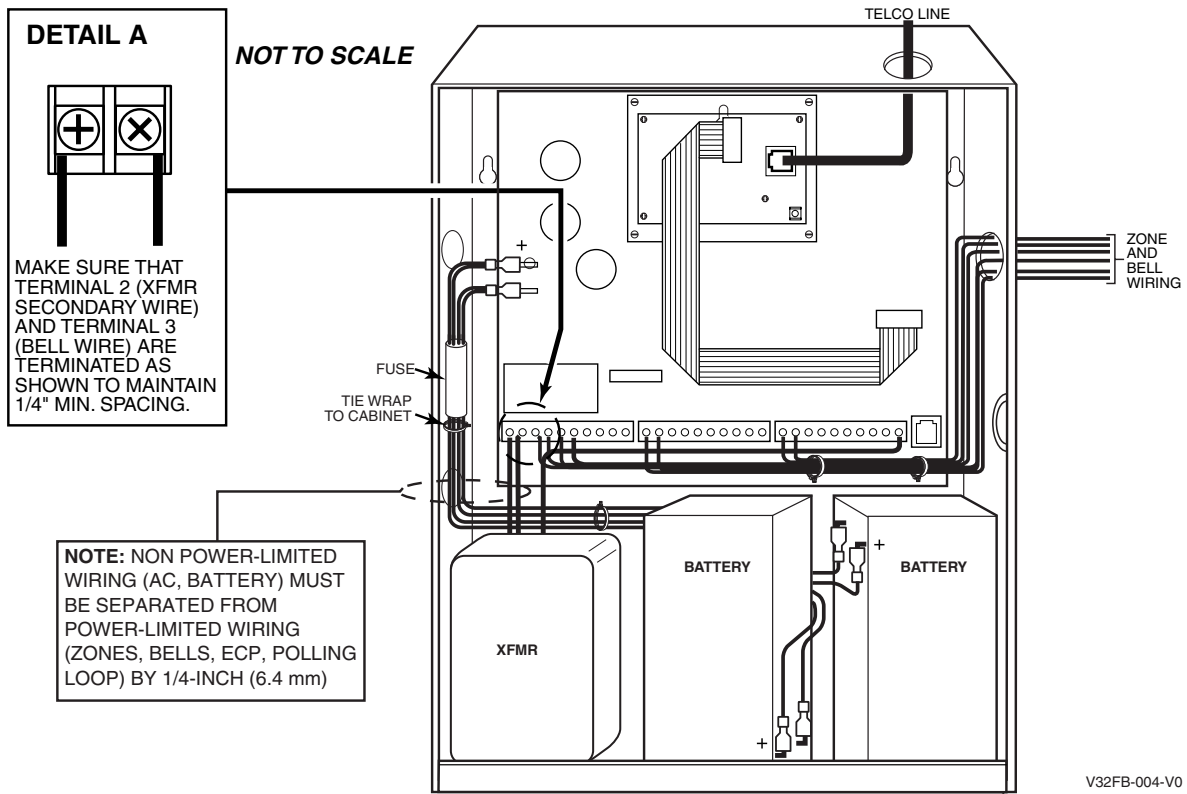

Figure 3-2: Separation of Circuits

Installing the Control's Circuit Board

To install the circuit board in the cabinet, perform the following steps:

Step	Action
1	Install the nylon standoffs (supplied) into the top corner holes of the mounting plate (Figure 3-3, Detail A.) Insert the top of the circuit board onto the two standoffs at the top of the mounting plate.
2	Place the board flat and secure to the mounting plate with the three accompanying screws and spacers as shown (Detail B.)

NOTES:

- Make sure that the mounting screws are tight. This ensures that there is a good ground connection between the PC board and the cabinet.
- Dress field wiring away from the microprocessor (center) section of the PC board. Use small holes in the sidewalls of the cabinet for anchoring field wiring using tie wraps (Figure 3-3).

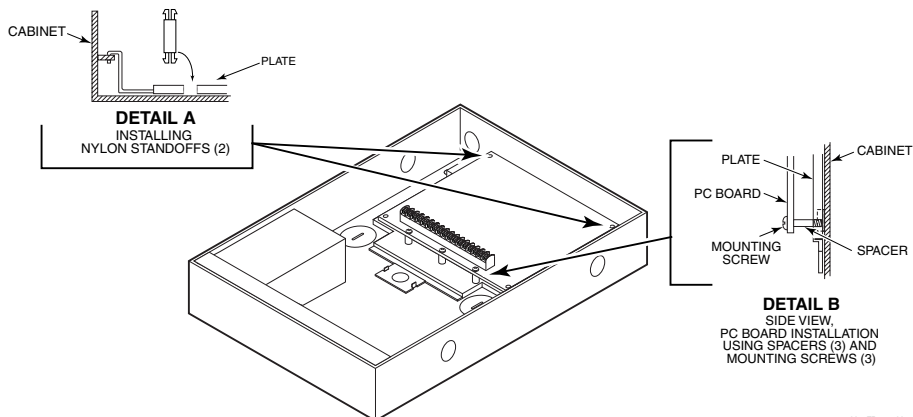

Figure 3-3: Mounting the PC Board

Mounting the Control in the Attack-Proof Cabinet (Suitable for Commercial Fire/Commercial Burglary Applications)

If you are installing a Vista-32FB in the attack-proof cabinet with the external transformer, follow the steps below.

Step	Action
1	Before mounting the circuit board, remove the metal knockouts for the wiring entry that you will be using. DO NOT ATTEMPT TO REMOVE THE KNOCKOUTS AFTER THE CIRCUIT BOARD HAS BEEN INSTALLED.
2	Using fasteners or anchors (not supplied), mount the control cabinet to a sturdy wall in a clean, dry area that is not readily accessible to the general public. The back of the cabinet has four holes for this purpose.

Installing the Cabinet Lock

To install the lock, perform the following steps:

Step	Action
1	Remove the cabinet door, and the lock knockout from the door. Insert the key into the lock (see Figure 3-1).
2	Position the lock in the hole, making certain that the latch will make contact with the latch bracket when the door is closed.
3	When correctly positioned, push the lock until its snap tabs hold it securely.

Use a Honeywell No. K4445 Lock (supplied).

UL

To provide certificated burglary service for UL installations, refer to the special requirements and *Figure 3-4 Cabinet Attack Resistance Considerations* to follow.

Mercantile Premises Listing Guidelines

- The panel door must be supervised. Mount the clip-on tamper switch (supplied) to the cabinet's right side wall, and wire it to zone 6.
- Assign zone 6 to a burglary partition. Program it for day trouble/night alarm (zone type 5) when only one burglary partition is used. Program it for 24-hr. audible alarm (zone type 7) when more than one burglary partition is used. Enable field 3*17 so that the system responds to a ground fault in accordance with its zone type rather than a ground fault response.
- All wiring between the transformer and panel must be run in conduit. Remaining wires do not need to be run in conduit.
- All unused knockouts must be plugged using the disc plugs and carriage bolts (supplied), as indicated in Figure 3-2.
- Fasten the cabinet door to the cabinet backbox using the 15 one-inch-long Phillips-head screws (supplied) after all wiring, programming, and checkout procedures have been completed.

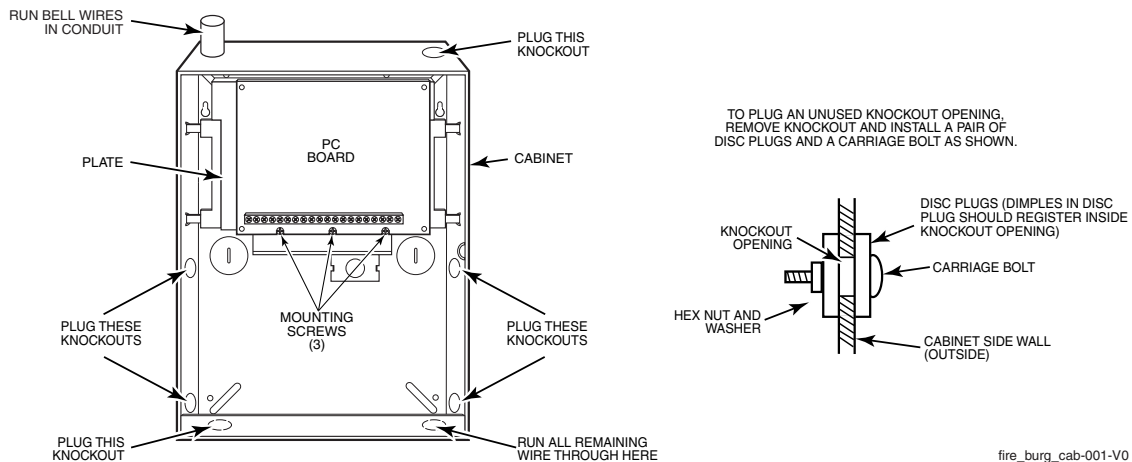

Figure 3-4: Cabinet Attack Resistance Considerations

Mercantile Safe and Vault Listing Guidelines

- Follow the guidelines given above for Mercantile Premises listing.
- For safe and vault installations, a Listed tamper switch, must be installed on the cabinet backbox to protect the cabinet from being removed from the wall. This device must also be connected to zone 6.

Commercial Fire Guidelines

For Commercial Fire installations, the following requirements apply (See Figure 3-5).

- System components mounted inside the cabinet must be placed so that all power-limited wiring is separated from all non-power-limited wiring (AC and battery) by a minimum of 1/4-inch (6.4mm).
- Non-power-limited wiring that exits the control panel (i.e., transformer wiring) must be run in conduit.
- All unused knockouts must be plugged.
- All wiring that exits the control panel must be strain-relieved (e.g., tie-wrapped).

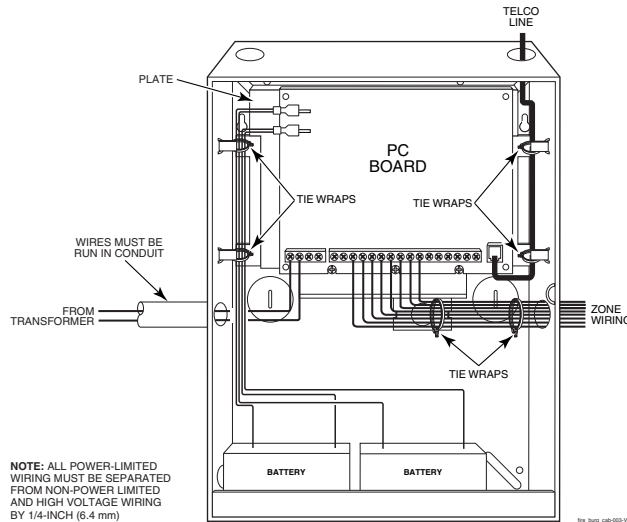

Figure 3-5: Commercial Fire Installation Using Attack-Proof Cabinet

Installing the Control's Circuit Board

To install the circuit board in the cabinet, perform the following steps:

Step	Action
1	Confirm the Mounting Plate is installed securely in the cabinet (Figure 3-6, Detail A). Install the nylon standoffs (supplied) into the top corner holes of the mounting plate (Detail B.) Insert the top of the circuit board onto the two standoffs at the top of the mounting plate.
2	Place the board flat and secure to the mounting plate with the three accompanying screws and spacers as shown (Detail C.)

NOTES:

- Make sure that the tabs on the side of the plate did not pop out during shipping and are inserted into the appropriate slots.
- Make sure that the mounting screws are tight. This ensures that there is a good ground connection between the PC board and the cabinet.
- Dress field wiring away from the microprocessor (center) section of the PC board. Use the mounting plate brackets on the left and right sidewalls of the cabinet for anchoring field wiring using tie wraps (Figure 3-3). These steps are important to minimize the risk of panel RF interference with television reception.

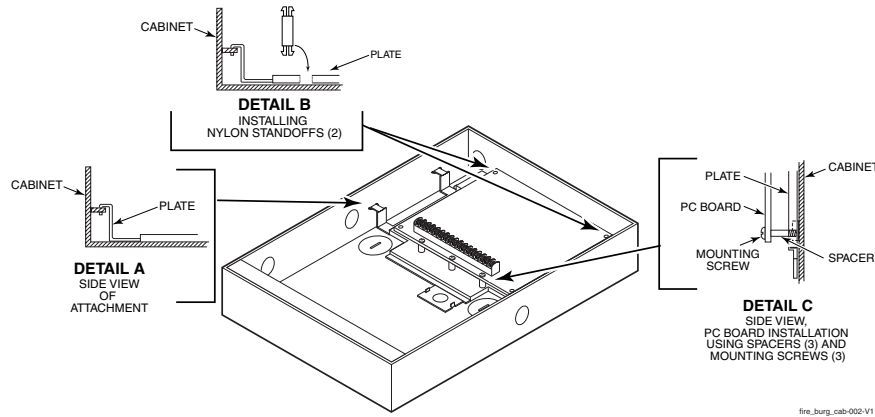

Figure 3-6: Mounting the PC Board in Attack-Proof Cabinet

Installing the Keypads

- Up to 31 addressable keypads (addresses 00-30) may be used (you may need to use an auxiliary power supply if the 1A aux. output is exceeded).
- Use a 2-line alpha display, 6160CR-2 (for fire only) or 6160 (for burglary only).

To wire the keypads, perform the following steps:

Step	Action												
1	Determine wire gauge by referring to the Wire Run Length/Gauge table below. <table border="1" style="margin: 10px auto;"> <thead> <tr> <th colspan="2">Wire Run Length/Gauge Table</th> </tr> <tr> <th>Wire Gauge</th> <th>Length</th> </tr> </thead> <tbody> <tr> <td>#22 gauge</td> <td>450 feet</td> </tr> <tr> <td>#20 gauge</td> <td>700 feet</td> </tr> <tr> <td>#18 gauge</td> <td>1100 feet</td> </tr> <tr> <td>#16 gauge</td> <td>1750 feet</td> </tr> </tbody> </table>	Wire Run Length/Gauge Table		Wire Gauge	Length	#22 gauge	450 feet	#20 gauge	700 feet	#18 gauge	1100 feet	#16 gauge	1750 feet
Wire Run Length/Gauge Table													
Wire Gauge	Length												
#22 gauge	450 feet												
#20 gauge	700 feet												
#18 gauge	1100 feet												
#16 gauge	1750 feet												
2	Wire keypads to a single wire run or connect individual keypads to separate wire runs. The maximum wire run length from the control to a keypad, which is homerun back to the control, must not exceed the lengths listed in the table.												
3	Run field wiring from the control to the keypads (using standard 4-conductor cable of the wire gauge determined in step 1).												
4	Connect keypad(s) to terminals 11, 12, 13, and 14 on the control board, see <i>Figure 3-7</i> . NOTE: In a Fire Application and when using only one keypad, it must be connected to Keypad Port 2, and must be mounted within 20 feet of the cabinet in conduit. The keypad on Port 2 is electrically isolated from those on Port 1 and will continue to function even if wiring problems prevent the other keypads from working properly.												



- The length of all wire runs combined, regardless of the wire gauge, must not exceed 2000 feet when unshielded quad conductor cable is used (1000 feet if unshielded cable is run in conduit, which acts a shield, or if shielded cable is used).
- If more than one keypad is wired to one run, then the above maximum lengths must be divided by the number of keypads on the run (e.g., the maximum length is 225 feet if two keypads are wired on a #22 gauge run).

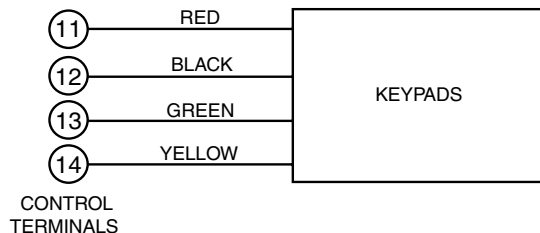

Figure 3-7: Keypad Connections to Control Panel

Commercial Fire Requirements

For commercial fire installations, the primary fire keypad must be installed on panel Keypad Port 2 and mounted within 20 feet of the control panel. External wiring must be run in conduit.

Additionally, you can install supplemental fire keypads and devices on ECP Port 1, using an ECP Isolator to separate all fire wiring from all burglary wiring (see Figure 3-8).

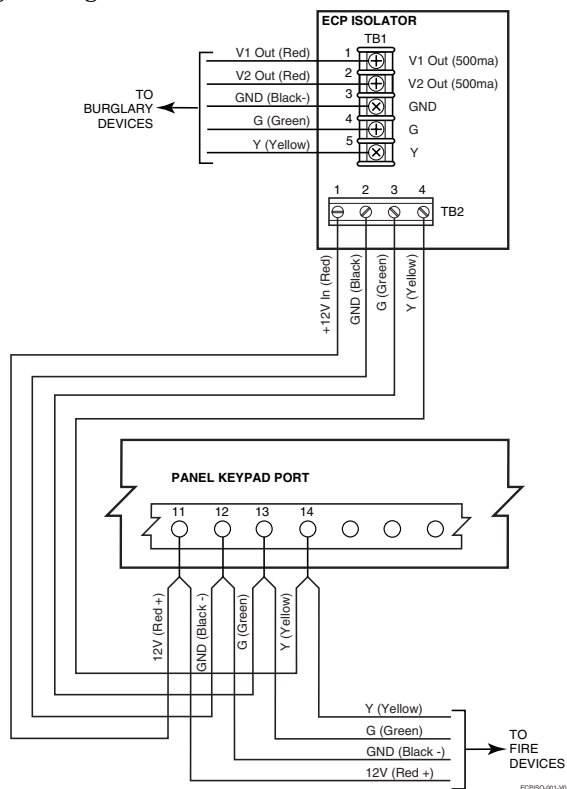

Figure 3-8. ECP Isolator Wiring

Addressing the Keypads



The keypads will not operate until they are physically addressed and enabled in the system's *Device Programming* in the #93 Menu Mode.

Set each keypad for an individual address (00-30) according to the keypad's instructions. Set an alpha keypad for address 00 and other keypads for higher addresses (00 and 01 are enabled in the system's default program). Any keypads set for address 02 and above will appear blank until they are enabled in the system's program. Each keypad must be set for a different address.



- Do not set any keypads to address 31 (nonaddressable mode). They will interfere with other keypads (as well as other devices) connected to the keypad terminals.
- If an "OC" or "OPEN CIRCUIT" message is present on a keypad, data from the control is not reaching the keypad. Please check your wiring.

Figure 3-9: This Figure Intentionally Left Blank

Installing External Sounders

The VISTA-32FB provides two Notification Appliance Circuits. Each circuit is rated as Special Application for Fire and 10VDC – 14VDC, 1.7A max., power-limited for Burglary.

NOTE: The total alarm current drawn from Auxiliary Power 1, Auxiliary Power 2, polling loop, Bell 1, and Bell 2 cannot exceed 2.3A for battery-independent operation.

The outputs have the following options:

- Selectable to activate by individual zone assignments
- Selectable for confirmation of arming ding.
- Selectable to chime when entry/exit or perimeter zones are faulted.
- Selectable for no timeout or timeout of 2-30 minutes.

UL

- Burglary alarm siren /bell must be programmed for a timeout of 16 minutes or longer.
- Commercial fire alarm systems require Notification Appliance Circuits to be supervised.

Notification Appliance Circuit Supervision

The VISTA-32FB monitors the Notification Appliance Circuits wiring for open and short circuit faults while the output is inactive. The system provides a trouble indication (Zone 970 Bell 1; 971 Bell 2) when an open occurs. When a short occurs between the Bell (+) and Bell (-) terminal wiring, or between the Bell (+) terminal wiring and earth ground the system provides a trouble indication (972 Earth Ground).

The VISTA-32FB indicates the trouble condition regardless of whether the system is armed or disarmed. The zone displays on the keypads, reports to the event log, and transmits to the central station (if programmed) on Partition 1. The trouble is cleared from the display by entering the user code + OFF.

UL

- Use only UL Listed sounding devices for UL installations.
- In Commercial Fire installations, the 4204CF cannot be used to drive sounders in the same physical area as sounders connected to the alarm outputs of the control panel.

Synchronization Requirements for Commercial Fire

Notification Appliance Circuit outputs must be wired to a Sync Module if more than one device is used. Follow instructions provided with Sync Module. Be sure to use the compatible Sync Module for the Alarm Indicating Device selected.

MANUFACTURER	SYNC MODULE MODEL NUMBER
GENTEX	AVSM
SYSTEM SENSOR	MDL
WHEELLOCK	DSM

UL

- All visual notification appliances within the same physical area must be synchronized.
- The bell outputs are listed as Special Application Notification Appliance Circuits.

Compatible Alarm Indicating Devices

ALARM INDICATING DEVICE TYPE	MANUFACTURER	MODEL #
RX7 UL Indoor Sounder, 12V	ADT	875936B
Horn Strobe 2w	GENTEX	GEC3-12, GES3-12, GEH-12
Horn Strobe 2w	GENTEX	GEC3-12, GES3-12, GEH-12
Horn Strobe 4w	GENTEX	GEC3-12, GES3-12, GEH-12
Horn Strobe 4w	GENTEX	GEC3-12, GES3-12, GEH-12
Chime, 12/24V, Selectable Tone & Volume, Red	SYSTEM SENSOR	CHR
Chime, 12/24V, Selectable Tone & Volume, White	SYSTEM SENSOR	CHW
Chime/Strobe, 12/24V, Selectable Candela, Tone & Volume, Red	SYSTEM SENSOR	CHSR
Chime/Strobe, 12/24V, Selectable Candela, Tone & Volume, White	SYSTEM SENSOR	CHSW
Horn, 12/24V, Red	SYSTEM SENSOR	HR
Horn, 12/24V, White	SYSTEM SENSOR	HW
Horn, 12/24V, Outdoor, Red	SYSTEM SENSOR	HRK

ALARM INDICATING DEVICE TYPE	MANUFACTURER	MODEL #
2-Wire Wall Mount Horn/Strobe, 12/24V, Standard Candela, Red	SYSTEM SENSOR	P2R
2-Wire Wall Mount Horn/Strobe, 12/24V, High Candela, Red	SYSTEM SENSOR	P2RH
2-Wire Wall Mount Horn/Strobe, 12/24V, Standard Candela, Red, Outdoor	SYSTEM SENSOR	P2RK
2-Wire Wall Mount Horn/Strobe, 12/24V, High Candela, Red, Outdoor	SYSTEM SENSOR	P2RHK
2-Wire Wall Mount Horn/Strobe, 12/24V, Standard Candela, White	SYSTEM SENSOR	P2W
2-Wire Wall Mount Horn/Strobe, 12/24V, High Candela, White	SYSTEM SENSOR	P2WH
4-Wire Wall Mount Horn/Strobe, 12/24V, Standard Candela, Red	SYSTEM SENSOR	P4R
4-Wire Wall Mount Horn/Strobe, 12/24V, High Candela, Red	SYSTEM SENSOR	P4RH
4-Wire Wall Mount Horn/Strobe, 12/24V, Standard Candela, Red, Outdoor	SYSTEM SENSOR	P4RK
4-Wire Wall Mount Horn/Strobe, 12/24V, High Candela, Red, Outdoor	SYSTEM SENSOR	P4RHK
4-Wire Wall Mount Horn/Strobe, 12/24V, Standard Candela, White	SYSTEM SENSOR	P4W
4-Wire Wall Mount Horn/Strobe, 12/24V, High Candela, White	SYSTEM SENSOR	P4WH
2-Wire Ceiling Mount Horn/Strobe, 12/24V, Standard Candela, Red	SYSTEM SENSOR	PC2R
2-Wire Ceiling Mount Horn/Strobe, 12/24V, High Candela, Red	SYSTEM SENSOR	PC2RH
2-Wire Ceiling Mount Horn/Strobe, 12/24V, Standard Candela, Red, Outdoor	SYSTEM SENSOR	PC2RK
2-Wire Ceiling Mount Horn/Strobe, 12/24V, High Candela, Red, Outdoor	SYSTEM SENSOR	PC2RHK
2-Wire Ceiling Mount Horn/Strobe, 12/24V, Standard Candela, White	SYSTEM SENSOR	PC2W
2-Wire Ceiling Mount Horn/Strobe, 12/24V, High Candela, Red	SYSTEM SENSOR	PC2WH
4-Wire Ceiling Mount Horn/Strobe, 12/24V, Standard Candela, Red	SYSTEM SENSOR	PC4R
4-Wire Ceiling Mount Horn/Strobe, 12/24V, High Candela, Red	SYSTEM SENSOR	PC4RH
4-Wire Ceiling Mount Horn/Strobe, 12/24V, Standard Candela, Red, Outdoor	SYSTEM SENSOR	PC4RK
4-Wire Ceiling Mount Horn/Strobe, 12/24V, High Candela, Red, Outdoor	SYSTEM SENSOR	PC4RHK
4-Wire Ceiling Mount Horn/Strobe, 12/24V, Standard Candela, White	SYSTEM SENSOR	PC4W
4-Wire Ceiling Mount Horn/Strobe, 12/24V, High Candela, White	SYSTEM SENSOR	PC4WH
2-Wire Wall Mount Strobe, 12/24V, Standard Candela, Red	SYSTEM SENSOR	SR
2-Wire Wall Mount Strobe, 12/24V, High Candela, Red	SYSTEM SENSOR	SRH
Wall Mount Strobe, 12/24V, Standard Candela, Red, Outdoor	SYSTEM SENSOR	SRK
Wall Mount Strobe, 12/24V, High Candela, Red, Outdoor	SYSTEM SENSOR	SRHK
Wall Mount Strobe, 12/24V, Standard Candela, White	SYSTEM SENSOR	SW
Wall Mount Strobe, 12/24V, High Candela, White	SYSTEM SENSOR	SWH
Ceiling Mount Strobe, 12/24V, Standard Candela, Red	SYSTEM SENSOR	SCR
Ceiling Mount Strobe, 12/24V, High Candela, Red	SYSTEM SENSOR	SCRH
Ceiling Mount Strobe, 12/24V, Standard Candela, Red, Outdoor	SYSTEM SENSOR	SCRK
Ceiling Mount Strobe, 12/24V, High Candela, Red, Outdoor	SYSTEM SENSOR	SCRHK
Ceiling Mount Strobe, 12/24V, Standard Candela, White	SYSTEM SENSOR	SCW
Ceiling Mount Strobe, 12/24V, High Candela, White	SYSTEM SENSOR	SCWH
Horn Strobe 12V, 4W	WHEELock	MT-121575W
Horn Strobe 12V, 2W	WHEELock	AS-121575W
Strobe 12V	WHEELock	RSS-121575W
Horn Strobe 12V, 2W	WHEELock	NS-121575W
Horn 12V/24V	WHEELock	NH-12/24
Horn 12V	WHEELock	AH-12
Horn 12V/24V	WHEELock	MT-12/24, MT4-12/24
Bell 12V	WHEELock	MB-G6-12, MB-G10-12

Table 3-1: BELL 1 AND BELL 2 MAXIMUM DEVICE RATING

NOTE: To use this table, the device Candela Setting and Horn Setting **MUST** match what is listed in the Table.

Mfg	Alarm Indicating Device Type	Model	Candela Setting	Horn Setting	Max # of Devices
Gentex	Horn Strobe 12V, 2w	GEC3-12,GES3-12,GEH-12	15	Mech-Temporal	6
Gentex	Horn Strobe 12V, 2w	GEC3-12,GES3-12,GEH-12	75	Mech-Temporal	2
Gentex	Horn Strobe 12V, 4w	GEC3-12,GES3-12,GEH-12	15	Continuous Mech	6
Gentex	Horn Strobe 12V, 4w	GEC3-12,GES3-12,GEH-12	75	Continuous Mech	2
System Sensor	Horn, Strobe12/24V	HR	-	-	38
System Sensor	Horn, Strobe12/24V	HW	-	-	38

Mfg	Alarm Indicating Device Type	Model	Candela Setting	Horn Setting	Max # of Devices
System Sensor	Horn, Strobe12/24V	HRK	-	-	38
System Sensor	Horn, Strobe12/24V	P2R	15	Temporal - High	10
System Sensor	Horn, Strobe12/24V	P2RH	15	Temporal - High	10
System Sensor	Horn, Strobe12/24V	P2RK	15	Temporal - High	10
System Sensor	Horn, Strobe12/24V	P2RHK	15	Temporal - High	10
System Sensor	Horn, Strobe12/24V	P2W	15	Temporal - High	10
System Sensor	Horn, Strobe12/24V	P2WH	15	Temporal - High	10
System Sensor	Horn, Strobe12/24V	P4R	15	Temporal - High	10
System Sensor	Horn, Strobe12/24V	P4RH	15	Temporal - High	10
System Sensor	Horn, Strobe12/24V	P4RK	15	Temporal - High	10
System Sensor	Horn, Strobe12/24V	P4RHK	15	Temporal - High	10
System Sensor	Horn, Strobe12/24V	P4W	15	Temporal - High	10
System Sensor	Horn, Strobe12/24V	P4WH	15	Temporal - High	10
System Sensor	Horn, Strobe12/24V	PC2R	15	Temporal - High	10
System Sensor	Horn, Strobe12/24V	PC2RH	15	Temporal - High	10
System Sensor	Horn, Strobe12/24V	PC2RK	15	Temporal - High	10
System Sensor	Horn, Strobe12/24V	PC2RHK	15	Temporal - High	10
System Sensor	Horn, Strobe12/24V	PC2W	15	Temporal - High	10
System Sensor	Horn, Strobe12/24V	PC2WH	15	Temporal - High	10
System Sensor	Horn, Strobe12/24V	PC4R	15	Temporal - High	10
System Sensor	Horn, Strobe12/24V	PC4RH	15	Temporal - High	10
System Sensor	Horn, Strobe12/24V	PC4RK	15	Temporal - High	10
System Sensor	Horn, Strobe12/24V	PC4RHK	15	Temporal - High	10
System Sensor	Horn, Strobe12/24V	PC4W	15	Temporal - High	10
System Sensor	Horn, Strobe12/24V	PC4WH	15	Temporal - High	10
System Sensor	Strobe12/24V	SR	15	Temporal - High	10
System Sensor	Strobe12/24V	SRH	15	Temporal - High	10
System Sensor	Strobe12/24V	SRK	15	Temporal - High	10
System Sensor	Strobe12/24V	SRHK	15	Temporal - High	10
System Sensor	Strobe12/24V	SW	15	Temporal - High	10
System Sensor	Strobe12/24V	SWH	15	Temporal - High	10
System Sensor	Strobe12/24V	SCR	15	Temporal - High	10
System Sensor	Strobe12/24V	SCRH	15	Temporal - High	10
System Sensor	Strobe12/24V	SCRK	15	Temporal - High	10
System Sensor	Strobe12/24V	SCRHK	15	Temporal - High	10
System Sensor	Strobe12/24V	SCW	15	Temporal - High	10
System Sensor	Strobe12/24V	SCWH	15	Temporal - High	10
Wheelock	Horn Strobe 12V, 4W	MT-121575W	15	Continuous/Hi	4
Wheelock	Horn Strobe 12V, 2W	AS-121575W	15	Continuous/Hi	6
Wheelock	Strobe 12V	RSS-121575W	15	na	6
Wheelock	Horn Strobe 12V, 2W	NS-121575W	15	Hi	7
Wheelock	Horn 12V/24V	NH-12/24	na	Hi	80
Wheelock	Horn 12V	AH-12	na	Hi	9
Wheelock	Horn 12V/24V	MT-12/24,MT4-12/24	na	Continuous Horn	10
Wheelock	Bell 12V	MB-G6-12,MB-G10-12	na	na	9
Gentex	Horn Strobe 12V, 2w	GEC3-12,GES3-12,GEH-12	15	Mech-Temporal	6
Gentex	Horn Strobe 12V, 2w	GEC3-12,GES3-12,GEH-12	75	Mech-Temporal	2
Gentex	Horn Strobe 12V, 4w	GEC3-12,GES3-12,GEH-12	15	Continuous Mech	6
Gentex	Horn Strobe 12V, 4w	GEC3-12,GES3-12,GEH-12	75	Continuous Mech	2
System Sensor	Horn, Strobe12/24V	HR	-	-	38
System Sensor	Horn, Strobe12/24V	HW	-	-	38
System Sensor	Horn, Strobe12/24V	HRK	-	-	38
System Sensor	Horn, Strobe12/24V	P2R	15	Temporal - High	10
System Sensor	Horn, Strobe12/24V	P2RH	15	Temporal - High	10
System Sensor	Horn, Strobe12/24V	P2RK	15	Temporal - High	10
System Sensor	Horn, Strobe12/24V	P2RHK	15	Temporal - High	10
System Sensor	Horn, Strobe12/24V	P2W	15	Temporal - High	10
System Sensor	Horn, Strobe12/24V	P2WH	15	Temporal - High	10
System Sensor	Horn, Strobe12/24V	P4R	15	Temporal - High	10
System Sensor	Horn, Strobe12/24V	P4RH	15	Temporal - High	10
System Sensor	Horn, Strobe12/24V	P4RK	15	Temporal - High	10
System Sensor	Horn, Strobe12/24V	P4RHK	15	Temporal - High	10
System Sensor	Horn, Strobe12/24V	P4W	15	Temporal - High	10
System Sensor	Horn, Strobe12/24V	P4WH	15	Temporal - High	10
System Sensor	Horn, Strobe12/24V	PC2R	15	Temporal - High	10
System Sensor	Horn, Strobe12/24V	PC2RH	15	Temporal - High	10
System Sensor	Horn, Strobe12/24V	PC2RK	15	Temporal - High	10

Mfg	Alarm Indicating Device Type	Model	Candela Setting	Horn Setting	Max # of Devices
System Sensor	Horn, Strobe12/24V	PC2RHK	15	Temporal - High	10
System Sensor	Horn, Strobe12/24V	PC2W	15	Temporal - High	10
System Sensor	Horn, Strobe12/24V	PC2WH	15	Temporal - High	10
System Sensor	Horn, Strobe12/24V	PC4R	15	Temporal - High	10
System Sensor	Horn, Strobe12/24V	PC4RH	15	Temporal - High	10
System Sensor	Horn, Strobe12/24V	PC4RK	15	Temporal - High	10
System Sensor	Horn, Strobe12/24V	PC4RHK	15	Temporal - High	10
System Sensor	Horn, Strobe12/24V	PC4W	15	Temporal - High	10
System Sensor	Horn, Strobe12/24V	PC4WH	15	Temporal - High	10
System Sensor	Strobe12/24V	SR	15	Temporal - High	10
System Sensor	Strobe12/24V	SRH	15	Temporal - High	10
System Sensor	Strobe12/24V	SRK	15	Temporal - High	10
System Sensor	Strobe12/24V	SRHK	15	Temporal - High	10
System Sensor	Strobe12/24V	SW	15	Temporal - High	10
System Sensor	Strobe12/24V	SWH	15	Temporal - High	10
System Sensor	Strobe12/24V	SCR	15	Temporal - High	10
System Sensor	Strobe12/24V	SCRH	15	Temporal - High	10
System Sensor	Strobe12/24V	SCRK	15	Temporal - High	10
System Sensor	Strobe12/24V	SCRHK	15	Temporal - High	10
System Sensor	Strobe12/24V	SCW	15	Temporal - High	10
System Sensor	Strobe12/24V	SCWH	15	Temporal - High	10
System Sensor	Speaker	SP200W	-	NA	NA
System Sensor	Speaker	SP201R	-	NA	NA
System Sensor	Speaker	SP201W	-	NA	NA
System Sensor	Speaker/Strobe	SP2C2415	15	NA	10
System Sensor	Speaker/Strobe	SP2C241575	15/75	NA	10
System Sensor	Speaker/Strobe	SP2C2430	30	NA	10
System Sensor	Speaker/Strobe	SP2C2475	75	NA	8
System Sensor	Speaker/Strobe	SP2C2495	95	NA	6
System Sensor	Speaker/Strobe	SP2C24115	115	NA	5
System Sensor	Speaker/Strobe	SP2C24177	177	NA	3
System Sensor	Speaker/Strobe	SP2R1224M	-	-	-
Wheelock	Horn Strobe 12V, 4W	MT-121575W	15	Continuous/Hi	4
Wheelock	Horn Strobe 12V, 2W	AS-121575W	15	Continuous/Hi	6
Wheelock	Strobe 12V	RSS-121575W	15	na	6
Wheelock	Horn Strobe 12V, 2W	NS-121575W	15	Hi	7
Wheelock	Horn 12V/24V	NH-12/24	na	Hi	80
Wheelock	Horn 12V	AH-12	na	Hi	9
Wheelock	Horn 12V/24V	MT-12/24,MT4-12/24	na	Continuous Horn	10
Wheelock	Bell 12V	MB-G6-12,MB-G10-12	na	na	9

Supervising the Notification Appliance Circuits

To wire the NAC using the supervision feature, install a 2K EOL resistor (Model 2EOL, supplied) across the last notification appliance on each Notification Appliance Circuit to be supervised.

Auxiliary Relay Connections

The VISTA-32FB provides a built-in Form C relay with contacts rated at 28VAC/VDC, 2.8A. The relay may be programmed (field 3*61) for one of the following functions:

- Alarm Activation
- Trouble/Supervisory Activation
- 4-Wire Smoke Detector Reset
- Battery Saver

Alarm Activation

(3*61 = 1 or 4) Steady activation in response to an alarm.

If field 3*61 = 1, the auxiliary relay remains active until Aux. Relay Timeout expires or until **User Code + OFF** is entered. This option can be used to provide an unsupervised Notification Appliance Circuit for supplementary strobes, sounders, etc. when wired to the Aux Power 1 or a separate power supply, see *Figure 3-10*.

If field 3*61 = 4, the auxiliary relay remains activated until **User Code + # + 67** is entered. By default, the relay is set to activate on alarm zones 1-8 with no timeout (field 3*61 = 1).

When field 3*61 = 1, the auxiliary relay can be programmed to give a brief activation for confirmation of arming ding (field 3*57) or Chime Mode (field 3*59).

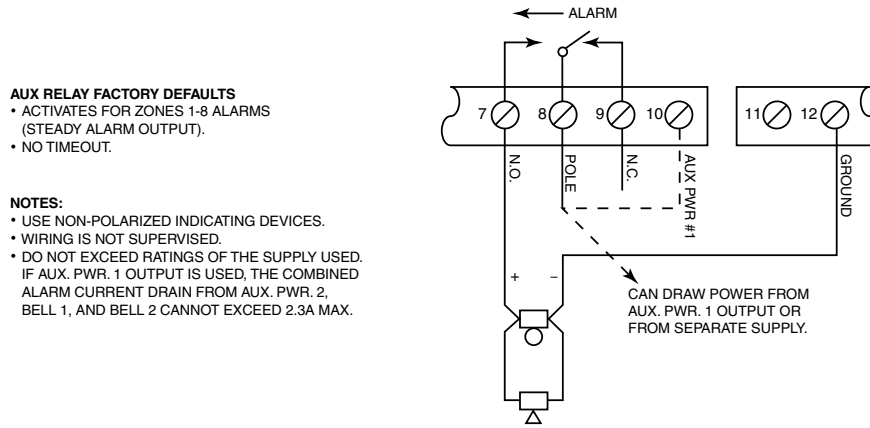

Figure 3-10: Wiring Auxiliary Relay for Alarm Activation

Trouble/Supervisory Activation

(3*61 = 0) Steady activation in response to any zone or system related trouble condition or to any fire supervisory condition. The auxiliary relay remains activated until all fault conditions have been corrected and a **User Code + OFF** is entered.

4-Wire Smoke Detector Reset

(3*61 = 2) Momentary (6-second) activation in response to a second entry of a **User Code + OFF** sequence following a fire alarm condition. This interrupts power to 4-wire smoke detectors connected to hardwired zones 1-8 and polling loop zones, allowing the detectors to be reset. Power to the detectors should be wired to the auxiliary relay and to Aux. Power 1 output, see Figure 3-11.

Battery Saver

(3*61 = 3) When this option is selected, the auxiliary relay is normally activated (e.g., N.O. and pole contacts are connected) and de-activates 4 hours after the start of AC Loss. Using this feature, non-critical loads, such as supplementary keypads, can be disconnected from the auxiliary power outputs, allowing a smaller capacity battery to be used. The relay re-activates within a few seconds after the AC power restores.

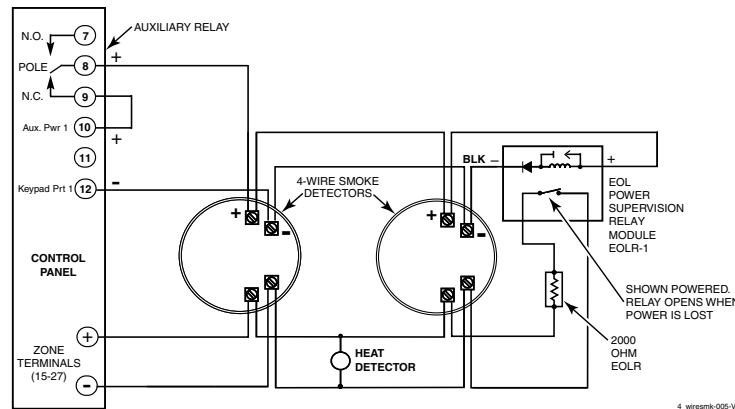

Figure 3-11: Wiring Auxiliary Relay for Smoke Detector Reset

Telephone Line Connections

The VISTA-32FB provides one main built-in dialer for communication to the central station and one optional 5140DLM Backup Dialer, both supervised for voltage and current on the phone lines.



Do not connect the system to telephone lines that require ground start service.



For Listed fire central station (UL864/NFPA 72) applications, use a Communications Device 7845i-ent alone, the main dialer with the 7845i-ent or use the main dialer with the 5140DLM.
 For listed fire remote station (UL864/NFPA 72) applications, use the main dialer with the 5140DLM.
 Telephone line supervision is required for commercial fire alarm systems.

Main Dialer Connections

To connect the main dialer, refer to the *Summary of Connections* diagram and perform the following steps:

Step	Action
1	Connect the main dialer to the telephone company lines using the RJ31X cable supplied.
2	If the dialer output is connected to telephone lines that have a telephone company MTU installed, cut the blue jumper (W6).

Installing the 5140DLM Backup Dialer



Do not connect the main dialer and the backup dialer to the same telephone company line.

To install the 5140DLM, refer to the *Summary of Connections* diagram and perform the following steps:

Step	Action
1	Mount the 5140DLM to the main PC board shield.
2	Connect the backup dialer to the telephone company lines using the RJ31X cable supplied.
3	Connect the backup dialer to the J3 connector on the main PC board using the ribbon cable (supplied with the module).
4	Connect the earth ground screw on the 5140DLM to the earth ground terminal (30) on the main PC board using 16AWG wire.
5	If the dialer output is connected to telephone lines that have a telephone company MTU installed, cut the blue jumper on the 5140DLM PC board.

Telephone Line Supervision

If the tip/ring voltage falls below approximately 25 volts (13 volts if the blue jumper is cut) or the handset current is less than approximately 10mA, the supervision circuits for the dialer output will indicate a fault condition. Faults on the phone lines are displayed as zones 974 (main dialer) and 975 (backup dialer).



- To prevent risk of shock, disconnect the phone lines at the telco jack before servicing the panel.
- If the communicator is connected to a telephone line inside a PABX, be sure the PABX has backup power supply that can support the PABX for 24 hours (central station usage). Many PABXs are not power-backed up, and connection to such a PABX results in a communication failure if power is lost.



The telephone line inputs have overvoltage protection in accordance with UL1459.

Reporting Formats



The system is shipped defaulted for Contact ID format. It is the only format capable of uniquely reporting all 32 zones, as well as openings and closings for all 75 users. This requires central stations to be equipped with the MX8000 receiver. If you need to update your MX8000 Receiver, contact your distributor.

The system supports ADEMCO Low Speed 3+1; 4+1; 4+2; SESCOA/RADIONICS 3+1; 4+1; 4+2; ADEMCO 4+2 Express; ADEMCO High Speed; ADEMCO Contact ID formats.

Dialer Operation

When only the main dialer is enabled (field 3*30 = 1, 0), the system attempts to route all messages over the main dialer output. . When both the main and backup dialers are enabled (field 3*30 = 1,1), the panel will Alternate Dialers by pairs (make two attempts to report on the Main Dialer, then make two attempts to report on the Back Up dialer). The panel will continue to do this to the Primary Phone number until it reaches its programmed attempts in 3*21, then it will do the same to the Secondary phone number. Test Report is always sent on Alternating dialers.

The communicator makes up to eight attempts to transmit the messages to one or both telephone numbers (primary and secondary), depending on the report routing options programmed. After the eighth attempt, the communicator hangs up and the system displays “COMM FAIL” on the keypad. The number of dialer attempts are programmed in field 3*21 (default = 8; must be restricted to 3, 4, or 5 if a secondary phone number is programmed).

Wiring Burglary and Panic Devices to Zones 1-8



The maximum zone resistance is 100 ohms for zones 1, 2 and 8, and 300 ohms for all other zones (excluding the 2K EOL resistor).

To wire burglary and panic devices to zones 1-8, connect sensors/contacts to the hardwire zone terminals (15 through 27). Connect N.C. and N.O. devices as follows:

- Connect N.C. devices **in series** with the high (+) side of the loop. The 2K EOL resistor must be connected in series with the devices, following the last device.
- Connect N.O. devices **in parallel (across)** the loop. The 2K EOL resistor must be connected across the loop wires at the last device.

Using 2-Wire Smoke Detectors on Zones 1 and 2

Zone 1 and 2 can support up to 16 2-wire smoke detectors each (32 total).



The alarm current on zones 1 and 2 supports only one smoke detector in the alarmed state.

When assigned zone type 9 or 16, the second entry of a User Code + off at a keypad interrupts power to these zones to allow detectors to be reset following an alarm.

Compatible 2-Wire Smoke Detectors

DETECTOR TYPE	MANUFACTURER	MODEL #
2-Wire Photoelectric Smoke Detector	DSC	FSA-210B
2-Wire Photoelectric Smoke Detector w/Heat Detector	DSC	FSA-210BT
2-Wire Photoelectric Smoke Detector	System Sensor	2W-B
2-Wire Photoelectric Smoke Detector w/Heat Detector	System Sensor	2WT-B
2-Wire Ionization Smoke Detector	System Sensor	1451 w/B401B base
2-Wire Photoelectric Low-Profile Smoke Detector	System Sensor	2151 w/B401 base *
2-Wire Photoelectric Smoke Detector	ESL	521B
2-Wire Photoelectric Smoke Detector w/Heat Detector	ESL	521BXT
2-Wire Photoelectric Smoke Detector w/Heat Detector	ESL	429AT

- This model may not be used on zones designated as Zone Type 16: Fire with Verification.
 - These smoke detectors are UL Listed for use with the Vista-32FB and are the only 2-wire smoke detectors that may be used.



- A combination of heat detectors and smoke detectors is not permitted on a zone programmed for fire verification.
- Fire installations require the use of a synchronization module to synchronize the sounders and strobes on the system.

Wiring 2-Wire Smoke Detectors to Zones 1 and 2



2K EOL resistors must be used on fire zones and must be connected across the loop wires of each zone at the last detector.

To wire 2-wire smoke detectors to zone 1 and/or zone 2, perform the following steps:

Step	Action
1	Select 2-wire smoke detectors from the list of compatible detectors.
2	Connect 2-wire smoke detectors across zone 1 (terminals 15 and 16), and/or zone 2 (terminals 17 and 18) as shown in <i>Figure 3-12</i> . Observe proper polarity when connecting the detectors.
3	Connect the EOL resistor at the last detector in the loop across the zone 1 terminals. The EOL resistor must be connected across the loop wires at the last detector.

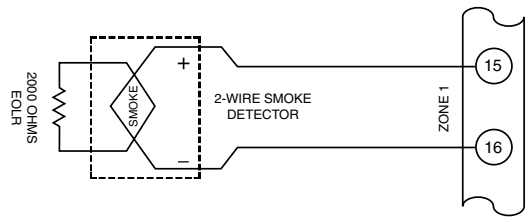

Figure 3-12: 2-Wire Smoke Detector on Zone 1 (for zone 2 use terminals 17 & 18)

Using 4-Wire Smoke Detectors on Zones 1-8

You may use as many 4-wire smoke detectors as can be powered from the panel's Auxiliary Power output without exceeding the output's rating (1A).



Auxiliary power to 4-wire smoke detectors is not automatically reset after an alarm, and therefore must be momentarily interrupted using either the auxiliary relay or a 4204 Relay Module.

Compatible 4-Wire Smoke Detectors

Use any UL Listed 4-wire smoke detector that is rated for 12VDC operation and that has alarm reset time not exceeding 6 seconds. Some compatible 4-wire smoke detectors are listed below

DETECTOR TYPE	MANUFACTURER	MODEL #
4-Wire Photoelectric Smoke Detector	DSC	FSA-410B
4-Wier Photoelectric Smoke Detector w/Heat Detector	DSC	FSA-410BT
4-Wire Photoelectric Smoke Detector w/Sounder & Heat Detector	DSC	FSA-410BST
4-Wire Photoelectric Smoke Detector w/Aux. Relay & Heat Detector	DSC	FSA-410BRT
4-Wire Photoelectric Smoke w/Aux. Relay, Sounder & Heat Detector	DSC	FSA-410BRST
End of Line Power Supervision Relay for FSA-410 Series Smoke Detectors	DSC	RM-2
Polarity reversal module for FSA-410 series Smoke Detectors	DSC	PRM-4WC
4-Wire Photoelectric Smoke Detector	System Sensor	4W-B
4-Wire Photoelectric Smoke Detector w/Heat Detector	System Sensor	4WT-B
4-Wire Photoelectric Smoke Detector w/Sounder & Heat Detector	System Sensor	4WTA-B
4-Wire Photoelectric Smoke Detector w/Aux. Relay & Heat Detector	System Sensor	4WTR-B
4-Wire Photoelectric Smoke Detector w/Aux. Relay, Sounder & Heat Detector	System Sensor	4WTAR-B
4-Wire Photoelectric Smoke Detector w/Aux. Relay, Sounder & Isolated Heat Detector	System Sensor	4WITAR-B
4-Wire Photoelectric Air Duct Smoke Detector, Extended Air Speed Range	System Sensor	DH100ACDCLP
4-Wire Ionization Air Duct Smoke Detector	System Sensor	DH100ACDCI

Wiring 4-Wire Smoke Detectors



- Power to 4-wire smoke detectors must be supervised with an EOL device (use a System Sensor EOLR-1) relay module connected as shown in *Figure 3-13*).
- A combination of heat detectors and smoke detectors is not permitted on a zone programmed for fire verification.
- Fire installations require the use of a synchronization module to synchronize the sounders and strobes on the system.

To wire 4-wire smoke detectors to zones 1-8, perform the following steps:

Step	Action
1	Select 4-wire smoke detectors (see list of compatible detectors shown previously in this section).
2	Connect detectors (including heat detectors, if used) across terminals of the zone selected. All detectors must be wired in parallel. See <i>Figure 3-13</i> .
3	Connect the EOLR at the last detector in the loop across the zone's terminals. You must connect the EOLR across the loop wires at the last detector.

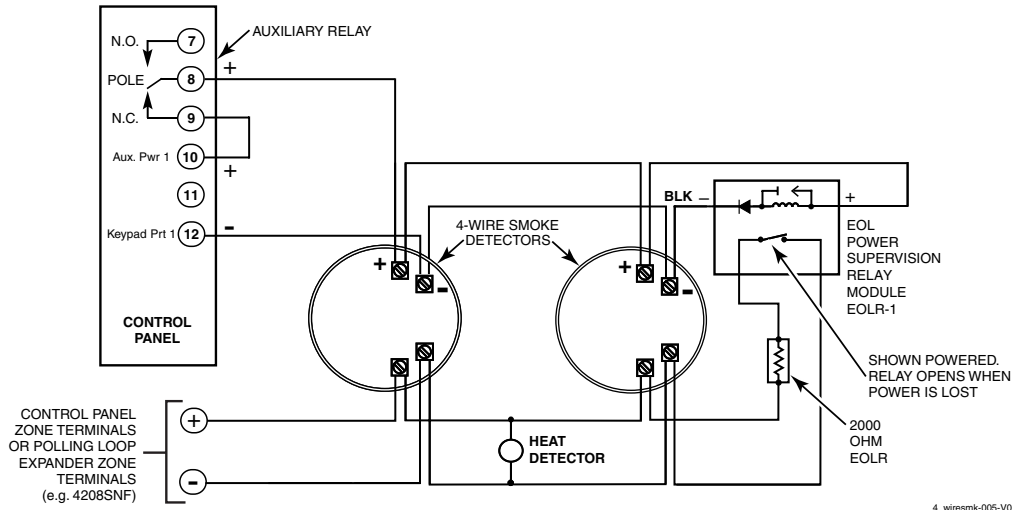

Figure 3-13: 4-Wire Smoke Detectors

Zone 6 Tamper Configuration

Zone 6 may be used as a tamper loop for the VISTA-32FB Cabinet Door Tamper Switch.

Assign zone 6 to a burglary partition. Program it for day trouble/night alarm (zone type 5) when only one burglary partition is used. Program it for 24-hr. audible alarm (zone type 7) when more than one burglary partition is used. Enable the Zone 6 Alternate Tamper Function (program field 3*17).

Using 2-Wire Latching Glassbreaks on Zone 8

Zone 8 can support 2-wire glassbreak detectors. The zone provides enough standby current to power up to 50 2-wire glassbreak detectors meeting the requirements listed below.

Compatible Glassbreak Detectors

Use detectors that meet the following ratings:

Standby Voltage:	5VDC–13.8VDC
Standby Resistance:	Greater than 20k ohms (equivalent resistance of all detectors in parallel)
Alarm Resistance:	Less than 1.1k ohms (see note below)
Alarm Current:	2mA–10mA
Reset Time:	Less than 6 seconds

NOTES:

You can use detectors that exceed 1.1k ohms in alarm, provided they maintain a voltage drop of less than 3.8 volts in alarm.

The IEI 735L Series detectors have been tested and found to be compatible with these ratings.



- The alarm current provided by zone 8 supports only one glassbreak detector in the alarmed state.
- Do not use other N.O. or N.C. contacts when using glassbreak detectors on zone 8. Other contacts may prevent proper glassbreak detector operation.

To wire 2-wire latching glassbreak detectors to zone 8, perform the following steps:

Step	Action
1	Select compatible 2-wire glassbreak detectors that meet the requirements stated previously.
2	Connect detectors across zone 8 (terminals 27 and 28). See Figure 3-14.
3	Connect the EOL resistor at the last detector in the loop across the zone’s terminals. You must connect the EOL resistor across the loop wires at the last detector.

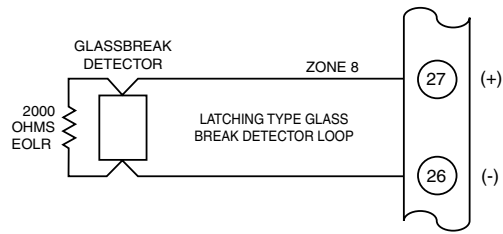

Figure 3-14: Wiring Latching Glassbreaks to Zone 8

Installing V-Plex Devices

The polling loop provides both power and data to the V-Plex devices, and is constantly monitoring the status of all zones enabled on the loop. The maximum current draw of all devices on the polling loop cannot total more than 128mA (unless the system uses a 4297 Polling Loop Extender Module).



Devices that can be programmed via either DIP switches or the built-in unique serial number **must** be set for serial number mode operation.

All devices on the polling loop must be wired in parallel to the [+] and [-] polling loop terminals of the control panel (28 and 29). You can wire from device to device, or have multiple branches connected directly to the control panel in a star configuration. If a module is using optional aux power, do not connect the [-] polling loop terminal to the device. Use the ground from the power source.



1. Do not run polling loop wires within 6" of AC power, telephone, or intercom wiring. The polling loop is carrying data between the control panel and the devices, interference on this loop can cause an interruption of this communication. The polling loop can also cause outgoing interference on the intercom or phone lines. If this spacing cannot be achieved, shielded wire must be used. (Note that the maximum total wire length supported is cut in half when shielded wire is used.)
2. The Quest 2260SN can be programmed as a "Smart Contact" in *Zone Programming*. This prevents those PIRs from displaying faults during the disarmed state. You cannot mix Quest 2260SN "Smart Contacts" with non-"Smart Contacts" in the system.
3. Twisted-pair is recommended for all wire runs.
4. No more than 64mA may be drawn on any individual wire run.
5. When a star configuration is used, the total length of all wire runs combined cannot exceed 4000 ft (2000 ft. if you are using unshielded wire in conduit or shielded wire).

UL

- The 4190SN right loop must not be used, and the left loop must be EOLR-supervised.
- The 4297 must be powered from the VISTA-32FB Auxiliary Power Output.

Compatible Polling Loop Devices

Model Number	Type
4297	Extender Module
4208SN	8 Zone V-Plex Interface
4208SNF	8 Zone V-Plex Class A Interface
269SN	V-Plex Holdup Switch
5192SD	Photoelectric Smoke Detector Devices
5192SDT	Photoelectric Smoke Detector w/Heat Detector
5193SD	Photoelectric Smoke Detector Device
5193SDT	Photoelectric Smoke Detector w/Heat Detector
4101SN	Serial Number Single-Output Relay Module
4208U	Universal 8-Zone Expander
4959SN	Aluminum Overhead Door Contact
4193SN	Serialized 2-Zone Expander
4293SN	Serialized 1-Zone Expander
4190SN	Serialized 2-Zone Expander

Model Number	Type
998MX	Serialized PIR
Quest 2260SN	Serialized PIR
IS2500SN	V-Plex PIR
Vplex-VSI	V-plex Short Isolator

NOTE: If using the new 5193SD/SDT V-Plex smoke detectors (or older 5192SD/SDT with the maintenance DIP sw enabled) the "Smart" option must be selected in zone programming or when they enroll unpredictable results may occur if the smoke goes into a High Sen or Low Sens condition.

To install polling loop devices, perform the following steps:

Step	Action												
1	Select devices from the list of compatible devices shown previously.												
2	Set the DIP switches in the device (if required). Refer to the device's instructions for the DIP Switch Tables.												
3	Mount each device in the desired location. Refer to the device's instructions.												
4	Run wires from the control panel to each device on the polling loop (see <i>Figure 3-15</i>). No individual wire run may exceed the lengths shown in the following table. <table border="1" style="margin: 10px auto;"> <thead> <tr> <th colspan="2">Maximum Polling Loop Wire Runs</th> </tr> <tr> <th>Wire Gauge</th> <th>Max. Length</th> </tr> </thead> <tbody> <tr> <td>#22 gauge</td> <td>650 feet</td> </tr> <tr> <td>#20 gauge</td> <td>950 feet</td> </tr> <tr> <td>#18 gauge</td> <td>1500 feet</td> </tr> <tr> <td>#16 gauge</td> <td>2400 feet</td> </tr> </tbody> </table>	Maximum Polling Loop Wire Runs		Wire Gauge	Max. Length	#22 gauge	650 feet	#20 gauge	950 feet	#18 gauge	1500 feet	#16 gauge	2400 feet
Maximum Polling Loop Wire Runs													
Wire Gauge	Max. Length												
#22 gauge	650 feet												
#20 gauge	950 feet												
#18 gauge	1500 feet												
#16 gauge	2400 feet												
5	Wire each device to the polling loop, making sure of the correct polarity (refer to the device's instructions).												

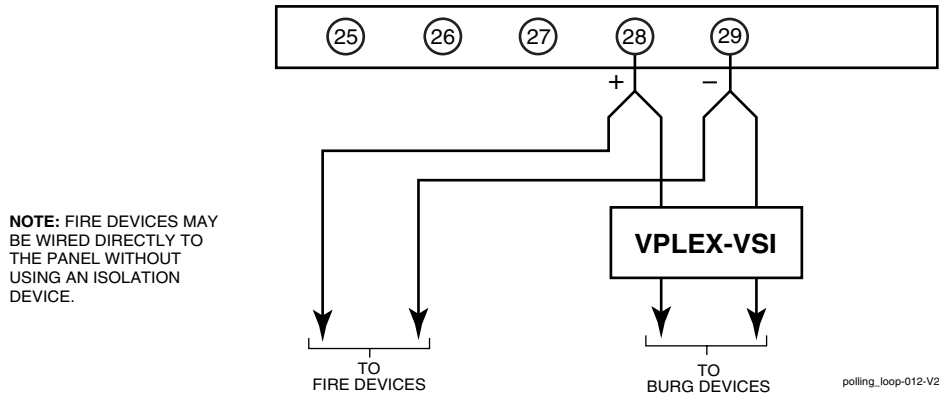

Figure 3-15: Polling Loop Connections to the Control Panel

Polling Loop Supervision

A short on the polling loop is indicated by a trouble on zone 997 and reports as a trouble condition only.

If a device on the polling loop fails (the panel cannot "see" that device), the system displays a trouble condition for all zones on that device. If the panel is armed when a device fails, and the zone is a burglary zone, the will go into alarm.



A trouble on zone 997 prevents a partition from being armed, unless all polling loop zones on that partition are bypassed.

Using the 4297 Polling Loop Extender

The 4297 Polling Loop Extender may be used to provide additional polling loop current, to extend the polling loop wire run length, and/or to provide individual electrically isolated polling loops. Refer to *Figures 3-16 and 3-17*, to follow.



DO NOT use the 4197 Polling Loop Extender module with the VISTA-32FB.



Be sure to include the total current drawn on the polling loop when figuring the total auxiliary load on the panel's power supply.

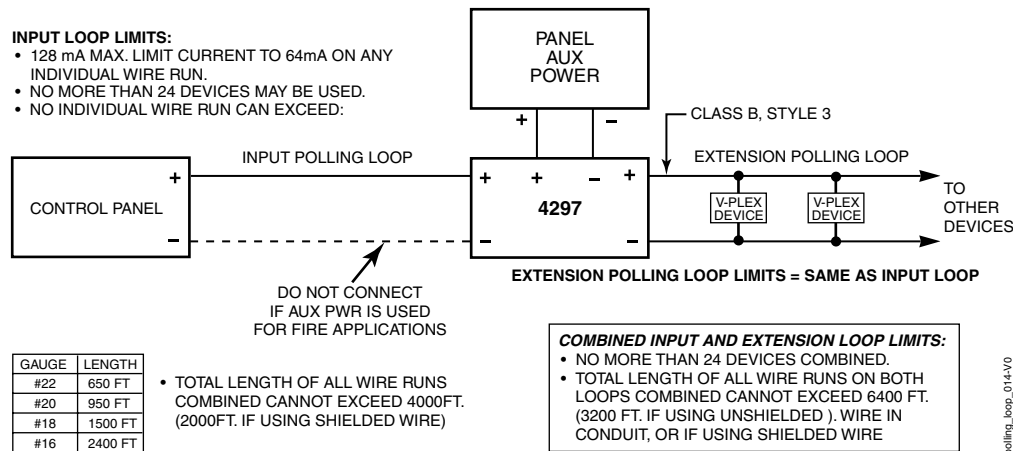
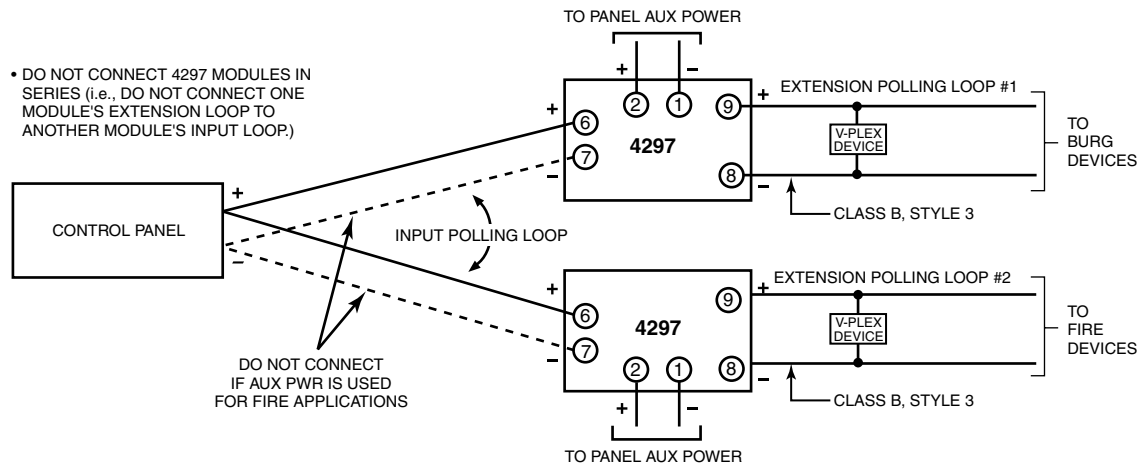

Figure 3-16: Polling Loop Connections Using One 4297 Extender Module



COMBINED INPUT AND EXTENSION LOOP LIMITS:

- NO MORE THAN 24 DEVICES COMBINED ON THE INPUT LOOP AND EXTENSION LOOP #1. NO MORE THAN 24 DEVICES COMBINED ON THE INPUT LOOP AND EXTENSION LOOP #2.
- TOTAL LENGTH OF ALL WIRE RUNS ON THE INPUT LOOP AND EXTENSION LOOP #1 COMBINED CANNOT EXCEED 6400 FT. (3200 FT. IF USING UNSHIELDED WIRE IN CONDUIT, OR SHIELDED WIRE). TOTAL LENGTH OF ALL WIRE RUNS ON THE INPUT LOOP AND EXTENSION LOOP #2 COMBINED CANNOT EXCEED 6400 FT. (3200 FT. IF USING UNSHIELDED WIRE IN CONDUIT, OR SHIELDED WIRE).
- WHEN USING THE 4297 TO EXTEND THE POLLING LOOPS, FIRE DEVICES MUST BE ON SEPARATE LOOPS FROM BURG DEVICES TO PROVIDE ISOLATION.

Figure 3-17: Polling Loop Connections Using Multiple Extender Modules

NOTE: The input loop limits stated in *Figure 3-16* apply to *Figure 3-17* as well.

Wireless Zone Expansion

The following table lists the receivers that may be used and the number of zones they support.

- UL**
- The 5881ENHC RF Receiver is listed for Commercial Fire and Commercial Burglary applications. The 5883H is UL Listed for Commercial Fire applications only. All other RF receivers are not UL Listed for Commercial applications.
 - For Commercial Fire installations the Receiver(s) must be mounted in a 5800BOX.

5800 Series Receivers

Receiver	Zones
5881ENHC	up to 32 (used in commercial fire or burglary applications)
5883H	up to 32 (used in commercial fire applications)

RF System Operation and Supervision

The 5800 RF system operation has the following characteristics:

- The receiver responds to a frequency of 345MHz.
- The receiver has a nominal range of 200 feet.
- Supervised transmitters send a supervisory signal every 70-90 minutes.
- Zones 988 and 990 are used to supervise the RF reception of receivers 2 and 1, respectively. The reception is supervised for the following two conditions:
 1. The receiver goes “deaf” (doesn’t hear from *any* transmitter) within a programmed interval of time (defined by program field 1*30).
 2. Proper RF reception is impeded (i.e., jamming or other RF interference). The control checks for this condition every 20 seconds.

- UL** A response type 19 (24-Hour Trouble) must be programmed for zones 990 (1st receiver) and 988 (2nd receiver) for UL installations.

- The 5881ENHC receiver contains front and back tampers that permit its use in commercial burglary installations. Therefore it must be mounted in its enclosure or a 5800BOX, or it will constantly report a tamper condition.
- The control checks the receiver connections about every 20 seconds. The receiver supervisory zone is 8 + 2-digit receiver device address (for example, Device address 05 = supervisory zone 805).

NOTE: This zone must be programmed with a response type (e.g., type 19 24-Hour Trouble) before it supervises the connection to the receiver.
- Use two identical receivers to provide either a greater area of coverage or redundant protection. They must be set for different addresses.
- Any zone from 1 to 31 can be used as a 5800 Series wireless zone, (zone 32 is reserved for a wireless keypad).

RF System Installation Advisories

- Place the receiver in a high, centrally located area. Do not place it on or near metal objects. This will decrease the range and/or block transmissions.
- Install the RF receiver at least 10 feet from the control panel or any keypads, to avoid interference from the microprocessors in these units.
- If dual receivers are used:
 - a. Both must be at least 10 feet from each other, as well as from the control panel and remote keypads.
 - b. Each receiver must be set to a different device address. The receiver set to the lower address is considered the 1st RF receiver for supervisory purposes.
 - c. The House IDs must be the same.
 - d. Using two receivers *does not* increase the number of transmitters the system can support (31 zones using the 5881ENHC or 5883H).

Installation and Setup of the 5881ENHC/5883H RF Receivers



Take note of the address you select for the RF receiver, as this address must be enabled in the system's *Device Programming* in the #93 Menu Mode.

To install the RF receiver, perform the following steps:

Step	Action
1	Mount the receiver, following the advisories stated previously. NOTE: Must be mounted in a 5800Box Enclosure for Fire applications.
2	Set the DIP switches in the receiver for the address (01-07). See <i>Figure 3-19</i> . Make sure the address setting is not being used by another device (keypad, relay module, etc.).
3	If installing a 5881ENHC , install a flat-head screw (supplied) in the case tamper tab as shown in <i>Figure 3-16</i> . When the receiver is pried from the wall, the tamper tab will break off and remain on the wall. This will activate a tamper switch in the receiver and cause generation of a tamper signal. Note that this signal will also be generated when the receiver's front cover is removed.
4	Connect the receiver's wire harness to the keypad terminals (11, 12, 13 and 14). Plug the connector at the other end of the harness into the receiver.
5	Refer to the Installation Instructions provided with the receiver for installations regarding antenna mounting, etc.

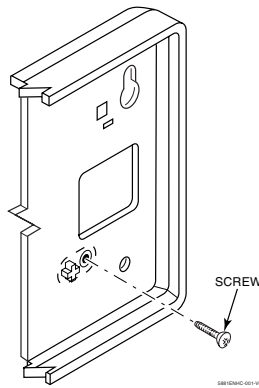

Figure 3-18: Installing the 5881ENHC with Tamper Protection

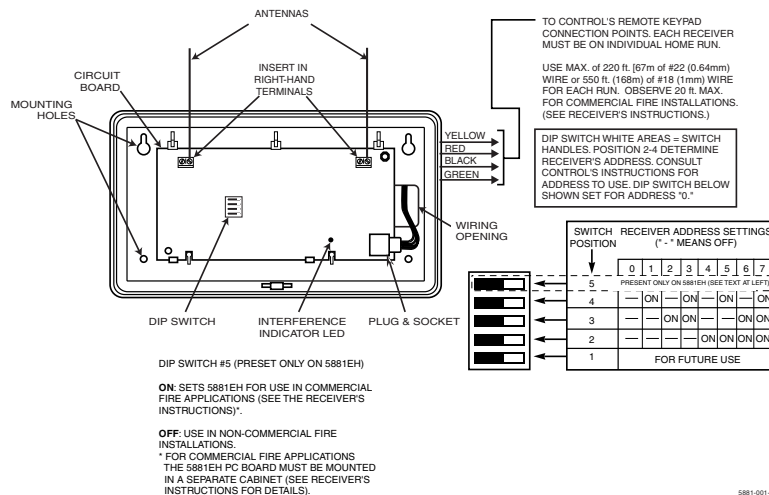

Figure 3-19: 5881/5883 RF Receiver (cover removed)

5800 Series Transmitter Setup

- Transmitters have built-in serial numbers that must be enrolled in the system using the *#93 Menu Mode Programming*, or via the downloader.
- Some transmitters can support more than one “zone” (loops or inputs) (e.g., 5817CB). Each loop must be assigned a different zone number.

Transmitter Supervision

Supervised RF transmitters send a check-in signal to the receiver at 70–90 minute intervals. If at least one check-in is not received from each supervised transmitter within a programmed period (field 1*31), the “missing” transmitter number(s) and “CHECK” or “TRBL” are displayed.

Some transmitters have built-in tamper protection, and announce a “CHECK” or “TRBL” condition if covers are removed.



If a loss of supervision occurs on a transmitter programmed for Fire, it reports in Contact ID as a Fire Trouble (373), not Loss of Supervision (381), to the central station.

Transmitter Input Types

All transmitters have one or more unique factory-assigned input (loop) codes. Transmitters can be programmed as one of the following types:

Type	Description
RF (Supervised RF)	Sends periodic check-in signals, fault, restore, and low-battery signals. The transmitter must remain within the receiver's range.
UR (Unsupervised RF)	Sends all the signals that the RF type does, but the control does not supervise the check-in signals. The transmitter may be carried off-premises.
BR (Unsupervised Button RF)	These send only fault signals. They do not send low-battery signals until they are activated. The transmitter may be carried off-premises. Not applicable in Commercial installations.

Transmitter Battery Life

Batteries in the wireless transmitters may last from 4 to 7 years, depending on the environment, usage, and the specific wireless device being used. Factors such as humidity, high or low temperatures, as well as large swings in temperature may all reduce the actual battery life in a given installation.

The wireless system can identify a true low battery situation, thus allowing the dealer or user of the system time to arrange a change of battery and maintain protection for that point within the system.

Compatible 5800 Series Transmitters

Model	Product	Input Type
5800CO	Carbon Monoxide Detector with Built-in Wireless Transmitter	RF
5817CB	Commercial Wireless Transmitter	RF
5869	Holdup Switch Transmitter	RF

Installing Output Devices

The VISTA-32FB supports up to 96 outputs. Each device must be programmed as to how to act (ACTION), when to activate (START), and when to deactivate (STOP). The 4204, 4204CF, and/or 4140SN may be used as output devices.

NOTE: The first 32 of the 96 Output Devices may be supervised (zones 601-632). Only the relays on 4204CF modules may be supervised. If supervision is programmed for other types of Output Devices, unpredictable results may occur.

Installing the 4204 (Burg Only) and 4204CF Relay Modules

Each 4204 module provides four relays with Form C (normally open and normally closed) contacts. Each 4204CF module can be used to provide one style-Y supervised Notification Appliance Circuit to the system. For 4204CF modules, only relays 1 and 3 on each module can be programmed.



The relay module will not operate until the device address you have set the DIP switches for is enabled in the control's *Device Programming* in the *#93 Menu Mode*.

UL

- Relays should not re-energize until the panel is fully reset.
- For Commercial Fire installations, only one notification appliance module may be used, and only one notification appliance output (A or B) may be used on that module.
- If the 4204CF relay is enabled for a NAC, it must follow the action of the NAC on the panel.
- Relays (aux and 4204's) cannot be used for off-premises signaling.
- In Commercial Fire installations, the 4204CF cannot be used to drive sounders in the same physical area as sounders connected to the alarm outputs of the control panel.
- Output devices are not intended for overriding automatic building and fire functions.

To install the relay modules, see *Figures 3-20 and 3-21* and perform the following steps:

Step	Action										
1	Set the 4204 or 4204CF's DIP switches for a device address 01-15 . Do not use an address being used by another device (keypads, RF receivers, etc.).										
2	Mount the 4204 and 4204CF modules per the instructions provided with them.										
3	Connect the module's wire harness to the control (11, 12, 13 and 14). Plug the connector on the harness to the module. When mounting remotely, homerun each module to the control. The table below shows the maximum wire run lengths. Refer to the instructions provided with the 4204CF for its maximum permissible wire lengths.										
	<table border="1"> <thead> <tr> <th>Wire Gauge</th> <th>Maximum Length</th> </tr> </thead> <tbody> <tr> <td>#22</td> <td>125 feet</td> </tr> <tr> <td>#20</td> <td>200 feet</td> </tr> <tr> <td>#18</td> <td>300 feet</td> </tr> <tr> <td>#16</td> <td>500 feet</td> </tr> </tbody> </table>	Wire Gauge	Maximum Length	#22	125 feet	#20	200 feet	#18	300 feet	#16	500 feet
Wire Gauge	Maximum Length										
#22	125 feet										
#20	200 feet										
#18	300 feet										
#16	500 feet										

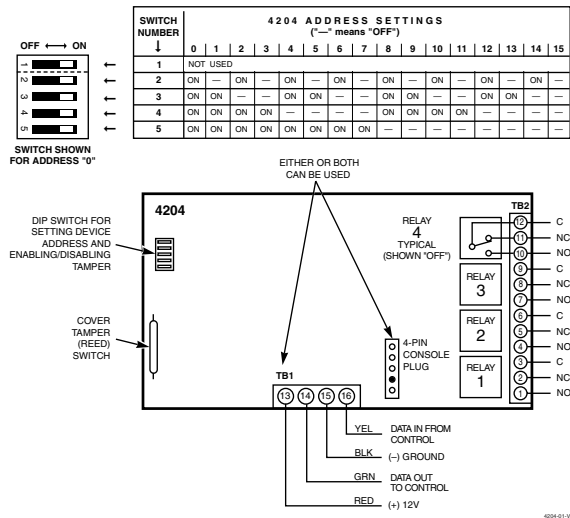

Figure 3-20: 4204 Relay Module

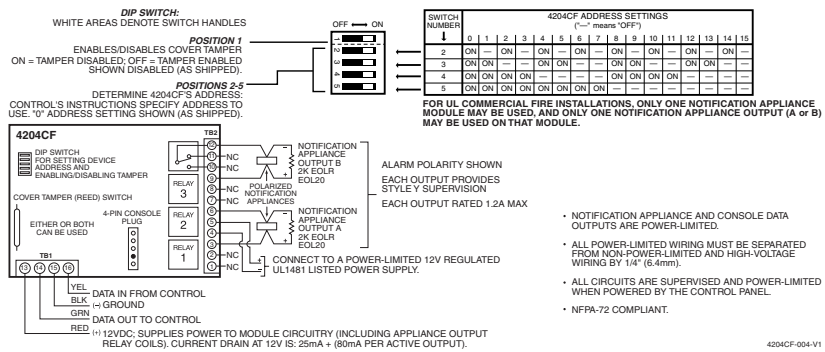

Figure 3-21: 4204CF Relay Module

Installing 4101SN Relay Modules

The 4101SN V-Plex Single Output Relay Module is a serial number polling loop output device. The 4101SN features the following:



The position of the relay is supervised, but not the actual external contact wiring.

- Form C relay contacts rated at 2A, 28VAC/VDC with contact supervision.
- One class B/style B EOLR-supervised auxiliary input zone.
- Operating power and communication with control panels via the V-Plex polling loop.
- Electronics mounted in a small plastic case with tamper-protected cover.



- If you are using ZONE # for the START of a polling loop output, and want the output to stop when the same zone restores, the STOP programming **must be blank**.
- No more than 20 polling loop outputs may be programmed for the same START or STOP condition in *Output Programming*.

Connect the device to the polling loop, terminals 28 (+) and 29 (-). Be sure to observe polarity.

Installing a Remote Keyswitch

A UL-Listed remote keyswitch, such as the Honeywell 4146, can be used for remote arming/disarming of the burglary part of the system and for silencing alarms. The keyswitch operates in only one particular partition. The keyswitch is wired across zone 7. This zone is no longer available as a protection zone. Make sure *15 is assigned to part (1-2). This sets zone 7 to response type 05.).

Operation

- A momentary short arms the partition in the AWAY mode, and a short held for more than 10 seconds arms the partition in STAY mode. A subsequent short disarms the partition.
- The keyswitch LEDs indicate the partition’s status (see table that follows).
- A momentary short silences Notification Appliance Circuits and keypad sounds, and disarms the system if it was armed. A subsequent short clears the alarm memory indication and resets 2-wire smoke and glassbreak detectors (if used).
- The keyswitch can be used to silence fire alarms without disarming the burglary portion (program a “9” in field *15). A momentary short silences alarm outputs only if a fire alarm is present.



In commercial fire installations, mount the keyswitch next to the primary keypad on keypad port 2 (J4 header) and wire in conduit within the same room as the control panel. The keypad displays the UL-required “ALARM SILENCED” when the keyswitch is used to silence a fire alarm.

LED Indications

Green	Red	Indication
On	Off	Disarmed & Ready
Off	Off	Disarmed & Not Ready
Off	On Steady	Armed Away
Off	Slow Flash	Armed Stay
Off	Rapid Flash	Alarm Memory



The keyswitch reports as user 0, if Open/Close reporting is enabled in field *40.

Keyswitch Tamper Operation

For Commercial Burglary installations, the tamper switch must be wired to zone 6, see *Figure 3-24*.

Program zone 6 for Day Trouble/Night Alarm (response type 5). When the keyswitch is removed from the wall, the tamper switch opens, causing an alarm or trouble on the zone. This also causes the control to disable keyswitch operation until the tamper is restored and the associated partition is disarmed.

Wiring for the Remote Keyswitch

To install the Honeywell 4146 keyswitch, perform the following steps:

Step	Action
1	Connect the Honeywell 4146 to the panel as shown in <i>Figure 3-22</i> .
2	If you are using the tamper, make sure it is connected to a zone.

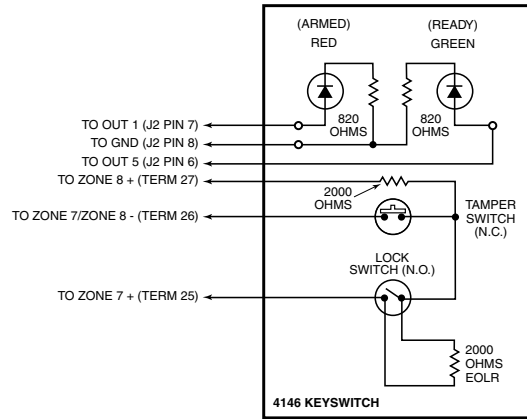

Figure 3-22: Remote Keyswitch Wiring

Installing a Remote Keypad Sounder (For Commercial Burglary use only)

An optional Amseco PAL 328N Piezo Sounder can be used to duplicate the sounds produced by the keypad’s built-in sounder. The remote sounder will duplicate all sounds (such as alarms, trouble beeps, etc.) except for the short beeps associated with keypad key depression. One application of this feature would be to produce chime beeps at a distant location from the keypads.

If used, program field 3*20 must be set to “0” and field *15 must be set to the desired partition number.

The remote sounder must be connected to the Output 5 on the J2 connector as shown in *Figure 3-23*.

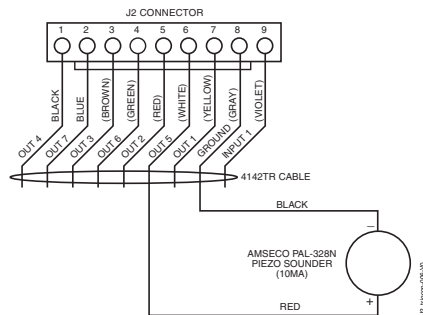

Figure 3-23: Remote Keypad Sounder Wiring

Communications Device Connected to the ECP Bus

The control can support IP or GSM Communications Device (7845i-ent, 7845GSM or 7845i-GSM) that connects to control panel’s keypad terminals. All messages programmed for transmission via the phone lines may also be sent via the Communications Device. These messages are transmitted in Contact ID format regardless of the format programmed for the control in fields 45 and 47. The 7845GSM or 7845i-GSM communicators may currently be used for Commercial Burglary systems only.



Contact ID format must be used in UL installations.

Supervision

The data lines between the control and the Communications Device, as well as certain functions in the Communications Device, can be supervised.

If communication is lost or a trouble condition occurs, both the Communications Device and the control’s dialer can be programmed to send a Trouble message to the central station.

NOTE: For complete information, see the Installation Instructions that accompany the Device.

Operation

The VISTA-32FB features **Dynamic Signaling Delay** and **Dynamic Signaling Priority** message reporting when a Communications Device is used. These message outputs are accessed through data fields *56 and *57, respectively. The Dynamic Signaling feature is designed to reduce the number of redundant reports sent to the central station.

The feature is described as follows:

Dynamic Signaling Delay (Field *56)

Select the time the panel should wait for acknowledgment from the first reporting destination before it attempts to send a message to the second destination. Delays can be selected from 0 to 225 seconds, in 15-second increments.

Dynamic Signaling Priority (Field *57)

Select the initial reporting destination for messages, Primary Dialer (0) or Communications Device (1).

The chart below provides an explanation of how the Dynamic Signaling feature functions.

If Priority (*57) is...	And message is...	Then...
Primary Phone No. ("0")	Acknowledged before delay expires	Message is removed from queue and no message is sent to Communications Device.
	Not acknowledged before delay expires	Message is sent to both the Primary Phone No. and Communications Device.
Communicator ("1")	Acknowledged before delay expires	Message is removed from queue and no message is sent to Primary Phone No.
	Not acknowledged before delay expires	Message is sent to both the Primary Phone No. and Communications Device.

Additional Communications Device reporting options are defined by selecting the events for each subscriber ID in fields 58 and 59. The reporting events are Alarms, Troubles, Bypasses, Openings/Closing, System Events, and Test. Also, within an enabled category, the specific event must be enabled for dialer reporting. If, for instance, zone 10 is enabled to report, but zone 11 is not, zone 10 will report via the Communications Device, but Zone 11 will not.

Messages are transmitted from the VISTA-32FB to the Communications Device on a “first in/first out” basis. If events occur at the same time, they are transmitted in order of priority. The priority from most to least important is: Fire Alarms, Panic Alarms, Burglary Alarms, Fire Troubles, Non-Fire Troubles, Bypasses, Openings/Closings, Test messages, and all other types of reports.

There are two subscriber IDs programmed into the Communications Device: primary and secondary. These correspond to the two subscriber ID’s programmed into the control for each partition. If a subscriber ID for a partition is not programmed (disabling reports to that central station), the events enabled for the corresponding subscriber ID in the Communications Device will not be transmitted.

If the event is to be reported to both phone numbers (dual reporting) then reporting through the Communications Device will be done in an alternating sequence. The first event in the queue is transmitted to both the primary and the secondary Communications Dvice central stations before transmitting the second event.

If split reporting is selected, then the Communications Device will send the appropriate reports to the primary and secondary central stations.

Installing the ECP Communications Device

To install the Communications Device, perform the following steps:

Step	Action
1	Mount the unit according to the instructions that accompany the Device.
2	Connect the data in/out terminals and voltage input terminals of the device to the control’s keypad connection points, terminals 11, 12, 13 and 14. See <i>Figure 3-24</i> .

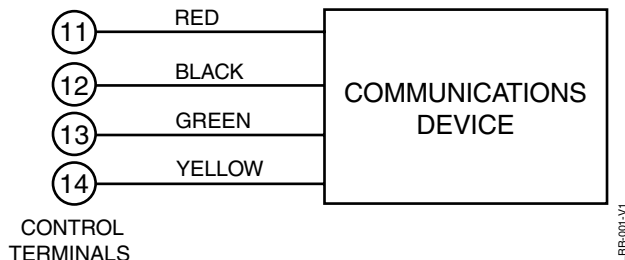

Figure 3-24: Wiring Communications Device to Keypad Terminals

Trouble Messages

The following messages are displayed on the 6160/6160CR-2 when a problem exists on the Communications Device:

1. “LRR Battery”: The battery connected to the Communications Device is low.
2. “PLL out of Lock”: The Communications Device has an internal fault and cannot transmit any messages.
3. “Early Power Detect”: RF power is detected without a valid transmission.
4. “Power Unattained”: Full RF power was never attained.
5. “Frwd. Power Loss”: RF power was not sustained throughout the transmission.
6. “Antenna Fault”: A problem with the antenna has been detected.
7. “LRR CRC is bad”: The Communications Device’s EEPROM is corrupt (the internal CRC is bad).

NOTES:

Items 2 and 3 require factory service.

Items 4 and 5 could be the result of a bad or low battery.

If the item 6 message appears, check the antenna, connection and cable; if they are secure, factory service is required.

All these messages are displayed in conjunction with the “CHECK 8xx” message, which indicates a trouble on the address to which the Communications Device is programmed in the control.

All of these events except Antenna Fault are sent to the event log and reported to the central station using Contact ID Event Code 333 (expansion device trouble). Antenna Fault uses Event Code 357. If the tamper is tripped on the Communications Device, it uses Event Code 341 (expansion device tamper).

Event Log Connections

This system has the ability to record up to 512 events of various categories in the Event Log (history log). Each event is recorded with the time and date of its occurrence (if real-time clock is set).

The categories are Alarm, Supervisory/Check, Bypass, Open/Close, System and Test conditions. The log may be viewed on an alpha keypad or printed on a serial printer.



- When using a printer, field 3*19 must be programmed for RS232 input (1).
- If you are using a serial printer, J2 pins 5 and 9 on the control panel cannot be used to interface with Automation software.

Connecting the Transformer

The control panel kit you purchased comes with the appropriate transformer: an external transformer or a factory mounted internal transformer. Both transformers have a manually resettable circuit breaker.

Use the following instructions for mounting and wiring the 18VAC secondary winding of the external transformer.

To connect the external transformer to the control, perform the following steps:

Step	Action
1	Remove the front cover of the enclosure.
2	Mount the enclosure to the wall near the control panel. The enclosure has four mounting holes on its back surface for this purpose.
3	Run 120VAC wiring to the enclosure in conduit. A dedicated circuit must be used.
4	Use wire nuts to splice the 120VAC wires to the transformer’s white and black primary leads.
5	Connect the earth ground post on the back of the enclosure to a good earth ground.
6	Run 16AWG wire in conduit from the enclosure to the control panel.
7	Use wire nuts to splice the transformer blue 18VAC secondary leads to the 16AWG wire. Connect the 16AWG wire at the control panel to terminals 1 and 2.
8	Replace the front cover of the enclosure and fasten it with the screws supplied.



- Use wires having insulation rated for at least 90°C operation and suitable for non-power limited applications.
- Use care to keep 18VAC wiring separated from all other wiring inside the control panel’s enclosure. This must be done by running, non-power-limited 18VAC wiring into the control panel’s enclosure via one of the knockouts on the left-hand side, and then tie-wrapping these wires to the tie-wrap loops located near the knockout.

Use the following instructions for wiring the 18VAC secondary winding of the internal transformer.

To connect the internal transformer to the control, perform the following steps:

Step	Action
1	Open the control panel cover.
2	Connect the blue 16AWG wire from the transformer at the control panel to terminals 1 and 2.
3	Connect the green 16 AWG wire (ground) at the control panel ground terminal 30.
4	Replace the front cover of the control panel.

Earth Ground Connections

In order for the lightning transient protective devices in this product to be effective, the designated earth ground terminal (terminal 30) must be terminated in a good earth ground. Recommended wire gauge for the ground connection is #16 AWG, run no farther than 30 feet.



The panel requires the earth ground connection for its lightning transient protection devices and in order to detect Ground Fault conditions.

To connect the earth ground to the transformer supplied with the VISTA-32FB, perform the following steps:

Step	Action
1	Run an earth ground wire into the built-in transformer's enclosure via the same knockout used for the 120VAC wiring.
2	Use a wire nut (not-supplied) to splice this earth ground wire to the green flying lead located inside of and bonded to the transformer's enclosure. Push the mated wires into the enclosure.
3	Connect the green flying lead, which emerges from the top of the transformer's enclosure to the earth ground terminal (terminal 30) on the VISTA-32FB.

To connect the earth ground to the 1451, perform the following steps:

Step	Action
1	Connect the earth ground post inside the 1451 enclosure to a good earth ground (use grounding methods specified in the National Electric Code).
2	Use a green nut (supplied) to secure the wire to the ground post. The ground wire should be the only wire under this nut.
3	Run a 16AWG wire from the ground post to the panel's earth ground terminal (30). Use a second green nut (supplied) to secure this wire to the ground post. This connection avoids ground loops that may occur when the 1451 and panel are connected to different earth ground systems.

Determining the Control's Power Supply Load

The VISTA-32FB must be supported by backup, rechargeable battery in the event of an AC power loss. A 12VDC, 12AH to 34.4AH battery must be connected to the control panel. Two 7AH batteries may be mounted in the small Fire-only cabinet. If additional capacity is required, use a Fire-Listed battery enclosure to house the batteries.

The battery's capacity must be sized to provide 24 hours (UL central station fire) followed by 5 minutes (fire only) or 15 minutes (fire and burglary) alarm time. Use only sealed lead-acid batteries with a minimum charging current handling capacity of 1.8A.

Use the worksheets that follow to calculate the total current for Auxiliary Power 1, Auxiliary Power 2, Bell 1, Bell 2, Polling Loop and the total current load of the control panel. In each worksheet, multiply each device's standby and/or alarm current by the number of units used.

Fill out the Battery Capacity Calculation Worksheet, following the other worksheets below, to determine the required capacity for the backup battery. Select a battery from the Battery Selection Table (found later in this section) that have a capacity greater than or equal to the calculated capacity.

1. In Worksheet 1, enter devices used on the polling loop. Calculate total current draw on the polling loop.

Worksheet 1: Total Polling Loop Current Draw

Polling Loop Device	Current	# of Units	Total
Polling Loop Subtotal (terminals 28 & 29 – 128mA) *			

*The total current cannot exceed 128mA. If total load exceeds 128mA, then a 4297 Loop Extender Module can be used. This module is powered from the panel's auxiliary power, and provides a separate polling loop output, which can support an additional 128mA load. Note that the total number of points connected to the panel cannot exceed 24.

2. In Worksheet 2, enter devices used on Auxiliary Power 1. Calculate standby and alarm currents, and then add to get Auxiliary Power 1 current subtotal.

Worksheet 2: Auxiliary Power 1 Current Load

Device Model #	Device Current X # of Units	Total Current	
		Standby	Alarm
Auxiliary Power 1 Subtotal (terminals 10 & 11)		1A max.	1.7A max.

3. In Worksheet 3, enter devices used on Auxiliary Power 2. Calculate standby and alarm currents, then add to get Auxiliary Power 2 current subtotal.

Worksheet 3: Auxiliary Power 2 Current Load

Device Model #	Device Current X # of Units	Total Current	
		Standby	Alarm
Auxiliary Power 2 Subtotal (pin 5 on keypad port 2)		400mA max.	400mA max.

4. In Worksheet 4, enter devices connected to the Bell 1 Output. Calculate alarm currents, then add to get the Bell 1 Output current subtotal.

Worksheet 4: Bell 1 Output Current Load

Device Model #	Device Current X # of Units	Total Current	
		Standby	Alarm
		XXXXXX	
		XXXXXX	
		XXXXXX	
		XXXXXX	
		XXXXXX	
		XXXXXX	
		XXXXXX	
Bell 1 Output Subtotal (terminals 3 & 4 – 1.7A max.)			

5. In Worksheet 5, enter devices connected to the Bell 2 Output. Calculate alarm currents, then add to get the Bell 2 Output current subtotal.

Worksheet 5: Bell 2 Output Current Load

Device Model #	Device Current X # of Units	Total Current	
		Standby	Alarm
		XXXXXX	
		XXXXXX	
		XXXXXX	
		XXXXXX	
		XXXXXX	
		XXXXXX	
Bell 2 Output Subtotal (terminals 5 & 6 – 1.7A max.)			

6. In Worksheet 6, enter the total calculated subtotals of all listed outputs from Worksheets 1 through 5, then add to get the combined current.

Worksheet 6: Total VISTA-32FB Current Load

	Total Current	
	Standby	Alarm
Polling Loop Subtotal		
Auxiliary Power 1 Subtotal		
Auxiliary Power 2 Subtotal		
Bell 1 Output Subtotal		
Bell 2 Output Subtotal		
VISTA-32FB PCB Current (Incl. 2-wire smoke detector loading on zones 1 & 2)	300mA	470mA
5140DLM Backup Dialer Module	5mA (inactive)	15mA (active)
Total Current Load (1.3 A max. standby; 2.8A max. alarm)		

NOTE: The 5140DLM actually draws 55mA when active. However, since the control panel PCB current includes the main dialer current, and since the main dialer is inactive when the 5140DLM is active, the 5140DLM imposes only a 15mA added load on the current supply.



The total control standby load must be limited to 1A for 24-hour standby time using a 12V, 34.4AH battery connected to the control.

Determining the Size of the Standby Battery

For burglary installations requiring 4-hour standby time followed by 15-minutes alarm time, use a 12AH battery to support all loads up to and including the maximum system load (e.g., 1A standby/2.7A alarm total control panel load). For fire installations requiring 24-hour, use the worksheet below to calculate the required battery capacity.



DO NOT use Gates batteries (sealed lead-acid type). These batteries require a different charging voltage than is supplied by the panel.

Use Worksheet 7 to determine the required backup battery capacity and use The Battery Selection Table to determine the battery model number. **A dual battery harness is supplied** that allows two batteries to be wired in parallel for increased capacity.

7. Using the total calculated from Worksheet 6, calculate the battery capacity required for the installation.

Worksheet 7: Battery Capacity Calculation Worksheet

Capacity	Formula	Calculated Value
Standby Capacity	Total standby current X 24 hours X 1.1 contingency factor.	
Alarm Capacity	Total alarm curr. X 0.083 (5 min) or X 0.250 (15 min)	
Total Capacity	Add standby and alarm capacities	

8. Battery Selection Table to select the appropriate battery for the installation.

Battery Selection Table

Capacity	Recommended Battery	Comment
4AH	Yuasa NP4-12	
7AH	Yuasa NP7-12	
12AH	Yuasa NP12-12	Fits in large mercantile cabinet only.
14AH	Yuasa NP7-12	Connect two in parallel.
17.2AH	Yuasa NPG18-12	Fits in large mercantile cabinet only.

9. Connect the battery, referring to *Figure 3-25*.



The standby battery is automatically tested for 10 minutes every 4 hours, beginning 4 hours after exiting Programming mode. In addition, entry into the Test mode initiates a battery test. The VISTA-32FB also runs a 5-second battery test every 60 seconds to check if the battery is connected.

NOTE: WHEN CONNECTING BATTERIES IN PARALLEL:
- USE BATTERIES FROM THE SAME MANUFACTURER AND WITH THE SAME VOLTAGE AND CAPACITY RATING.
- USE BATTERIES WITH APPROXIMATELY SAME AGE AND STATE OF CHARGE.
- USE CABLES PROVIDED AND **OBSERVE POLARITY!**
- IT IS RECOMMENDED THAT ALL BATTERIES BE REPLACED AT SAME TIME, EVEN IF ONLY ONE BATTERY HAS BECOME WEAK.
- AS LONG AS ONE GOOD BATTERY REMAINS CONNECTED, THE ONCE PER 60 SECOND BATTERY TEST WILL NOT DETECT THE DISCONNECTION OF REMAINING BATTERIES.

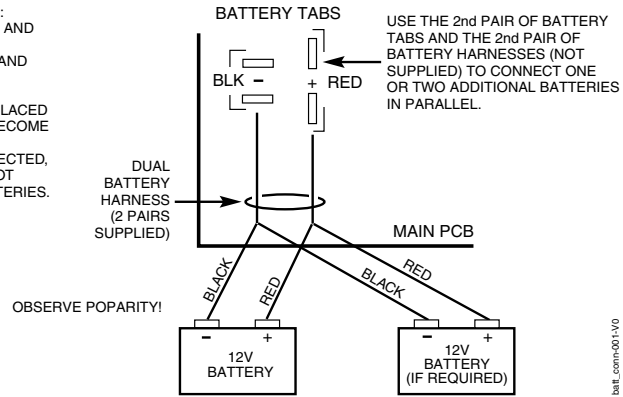

Figure 3-25: Connecting the Backup Batteries

Programming

Program Modes

There are two programming modes for the VISTA-32FB. These are the Data Field Program Mode and the #93 Menu Mode. The Data Field Program Mode is where many system options are programmed. The #93 Menu Mode is an interactive mode that requires a 2-line alpha keypad (6160/6160CR-2).



The factory-loaded defaults (*97) enable keypad addresses 00-01 only. An alpha keypad set to one of these addresses must be used to program the system initially.



Local keypad programming can be disabled through Compass downloading software. If this is done, Program mode can only be accessed via the downloading software.

Entering and Exiting Programming Mode

Enter Programming mode using either method a or b:

- a. Press both the [*] and [#] keys at the same time within 30 seconds after power is applied to the control.
- b. Enter the **Installer Code + [8] + [0] + [0]** keys. The factory installer code can be changed once in the Program mode (field *00).

NOTE:

The default Installer Code is 5140.

Exit the Programming mode by either method a or b:

- a. Press [*] + [9] + [8]. Exiting by this method prevents the installer code from being used to re-enter Programming mode. Only method “a” can be used to re-enter Programming mode.
- b. Press [*] + [9] + [9]. Exiting by this method permits the installer code to be being used to re-enter Programming mode.

Data Field Programming Mode

In the Data Field Program Mode you may access any field simply by entering either [*] or [#] + the field number:

- To write or change information in a field press [*] + the field number (*03).
- To read the information in a field press [#] + the field number (#03).

When the entries for a field are completed, the keypad beeps three times and advances to the next field.

SUMMARY OF DATA FIELD PROGRAMMING COMMANDS

*91	Select partition for programming partition-specific fields
*92	Display the software revision level of the control panel
*93	Enter Menu mode programming
*94	Go to next page of fields
*99	Go back to previous page of fields or exit Programming Mode with no installer code lockout
*98	Exit Programming Mode with Installer Code lockout

Moving from One Page of Programming to Another

The data fields are grouped into three levels (referred to as “pages”). The first page is accessed as soon as Programming Mode is entered.

The second and third pages of data fields are indicated at the keypad by a 1 and 2, respectively, in front of the

2-digit field address. “ALT PROGRAM MODE” is displayed along with a “100”, “200” or “300,” indicating which page of program fields is accessed.

To access the next level of programming fields:

- 1 Press *94.
- 2 Press [*] + [XX], where XX = the last two digits of the program field, and make the desired entry.

NOTES:

Press *94 to move to 2nd page, (fields 1*01 - 1*76); press *99 to move back to 1st page.

Press *94 to move to 3rd page (fields 2*00 - 2*88); press *99 to move back to 2nd page.

Press *94 to move to 4th page, (fields 3*00 - 3*85); press *99 to move back to 3rd page.

Entry Errors

- If an address is improperly entered, the keypad displays “Not Used” or “FC.”
- If a program entry is improperly entered (for example, a larger number than is permitted), the keypad display will go blank.

In either of the above cases, simply re-enter [*] + the correct field number and then enter the correct data.

Programming System-Wide Data Fields

Values for some programming fields are system-wide (global), and some can be different for each partition (partition-specific).



The partition-specific programming fields are automatically skipped when programming the global fields. If the system has only one partition, the partition-specific fields *are not* automatically skipped.

To program system-wide data fields, perform the following steps:

Step	Action
1	Enter Program Mode: Installer Code + 8 0 0 . The following display appears: <div style="border: 1px solid black; padding: 5px; width: fit-content; margin: 5px 0;"> Program Mode *Fill # View – 00 </div>
2	If the control has not been programmed before, enter *97 to load factory defaults.
3	Press [*] and enter the first field number to be programmed (for example, *00, Installers Code). Make the desired entry. When the field is complete, the keypad beeps three times and advances to the next field. If you do not want to change the next field, press [*] and enter the next field number to be programmed. <div style="border: 1px solid black; padding: 5px; width: fit-content; margin: 5px 0;"> First Page of fields (*00 - *90) </div> To move to the next page of fields, press *94. To return to the previous page, press *99.
4	Press *99 or *98 to exit Program Mode.

NOTE: If the number of digits that you enter in a data field is fewer than the maximum permitted (for example, a phone number), the keypad displays the last entry and waits. To proceed, enter [*] + the next data field you wish to program.

Programming Partition-Specific Data Fields

To program partition-specific data fields once in Program Mode, do the following:

Step	Action
1	Enter Program Mode: Installer Code + 8 0 0
2	Press *91, which will prompt you for the partition number desired.
3	Enter a partition-specific field number (e.g., *09) to begin programming. When the first field’s entry is completed, the next partition-specific field is automatically displayed. When all partition-specific fields are programmed, the system returns to the global programming fields (page 1 fields).
4	Repeat this procedure for each partition in the installation.

NOTE: To return to the global program fields before finishing all fields, enter any global field number.

Programming Partition-Specific Fields

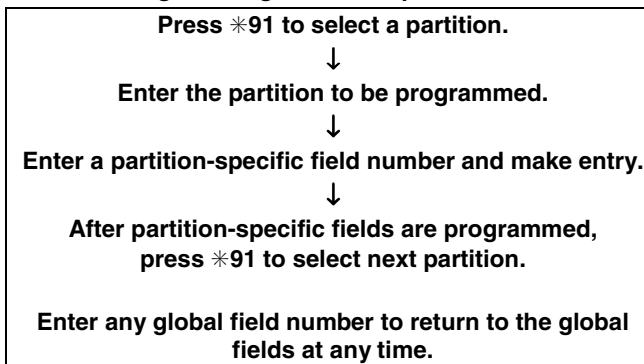

#93 Menu Mode Programming

The #93 Menu Mode is an interactive mode through which much of the system’s programming is done. In this mode, there are “question and answer” prompts that can be accessed once Data Field Program Mode has been entered. These prompts require a 2-line alpha keypad (6160/6160CR-2).

After programming all system-related programming fields in the usual way, press #93 while still in programming mode to display the first choice of the menu-driven programming functions. Press 0 (NO) or 1 (YES) in response to the displayed menu selection. Pressing 0 will display the next choice in sequence.

Below are the main menu selections. For details refer to the *VISTA-32FB Programming Guide*.

MAIN MENU	OPTIONS
ZONE PROG? 1 = YES 0 = NO 0	For programming the following: <ul style="list-style-type: none"> • Zone Number • Zone Response Type • Partition Number for Zone • Dialer report code for zone • Input Device Type for zone (whether RF, polling loop, etc.) • Enrolling serial numbers of 5800 Series transmitters and serial polling loop devices into the system.
EXPERT MODE? 1 = YES 0 = NO 0	Same as Zone Programming except: <ul style="list-style-type: none"> • Done with a minimum number of keystrokes. • Can program wireless keys using pre-defined templates. <p>NOTE: All the zone attributes cannot be programmed using the Expert Mode.</p>
REPORT CODE PROG? 1 = YES 0 = NO 0	For programming the following: <ul style="list-style-type: none"> • Alarm report codes for zones • Restore and supervisory codes • All other system report codes
ALPHA PROG? 1 = YES 0 = NO 0	For entering alpha descriptors for the following: <ul style="list-style-type: none"> • Zone Descriptors • Default Screen • Custom Words • Partition Descriptors
DEVICE PROG? 1 = YES 0 = NO 0	For defining the following device characteristics for addressable devices, including keypads, RF receivers (5881ENHC, 5883H), output relay modules (4204/4204CF) and ECP Communications Device <ul style="list-style-type: none"> • Device Address • Device Type • Keypad Options (including Partition assignment) • RF House ID • Communicator Options (including Programming communicator)
OUTPUT PGM? 1 = YES 0 = NO 0	For defining output device functions.
RLY VOICE DESCR? 1 = YES 0 = NO 0	Must be set to "0".
CUSTOM INDEX ? 1 = YES 0 = NO 0	Must be set to "0".
ACCESS POINT PGM 1 = YES 0 = NO 0	Must be set to "0".
ACCESS GRP PGM 1 = YES 0 = NO 0	Must be set to "0".
EVENT/ACTION PGM 1 = YES 0 = NO 0	Must be set to "0".

Following is a list of commands used while in the Menu Mode:

#93 Menu Mode Programming Commands

#93	Enters Menu Mode.
[*]	Serves as [ENTER] key. Press to have keypad accept entry.
[#]	Backs up to previous screen.
0	Press to answer NO.
1	Press to answer YES.
00, or 000+[*]	Quits Menu Mode and goes back to Data Field Programming Mode, if entered at first prompt of each main menu option.

Zone Number Designations

The VISTA-32FB supports up to 32 zones of hardwire, polling loop and/or wireless protection, distributed between two partitions. The following table lists the zone numbers and the types of sensors that can be used with each, and some alternate functions of the zones.

Zone	Function
001 & 002	2-wire Smoke Detectors (if used)
005	Audio Alarm Verification (if used)
006	Cabinet Tamper/Ground Fault (if used)
007	Keypad (if used)
008	Latching-Type Glassbreak Detectors (if used)
001-032	Traditional Hardwired Zones
001-032	5800 Series Wireless Devices
010-032	Polling Loop Devices
995	* + 1 Panic (Do not use in Fire Alarm applications)
996	# + 3 Panic (Do not use in Fire Alarm applications)
999	* + # Panic (Do not use in Fire Alarm applications)

Zone Defaults

Zone #	Zone Type	Zone #	Zone Type
001	09	800-830	00
002	09	970	19
003	03	971-974	19
004	03	975	00
005	03	988 & 990	00
006	03	992	N/A
007	03	995	00
008	03	996	00
010-032	00	997	19
601-632	00	999	06

NOTE: Zone 992 is the Duress zone. Programming of the zone response type is not applicable. This zone does not require a zone type, only the report code programming.

Zone Index

The zones are designated as follows:

ZONE # RANGE	ZONE FUNCTION	ACTUAL ZONE
001 – 032	Protection zones	As indicated
601 – 632	Relay Supervisory Zones	6 + 2-digit Relay Number; e.g., Relay Number 03, if supervised, is zone 603. NOTE: Relay supervision should be used only for relays on the 4204CF modules.
800 – 830	ECP Device Supervisory Zones	8 + 2-digit Device Address; e.g., Device Address 01, if supervised, is zone 801.
970-977, 988, 990, & 997	System Supervisory Zones	970: Bell 1 Output 971: Bell 2 Output 972: Earth Ground 973: J2 Input 1 (Communicator) 974: Dialer 1 975: Dialer 2 976: Auxiliary Relay 977: J2 Communicator Trigger Outputs 988: 2 nd Wireless Receiver – not receiving signals 990: 1 st Wireless Receiver – not receiving signals 997: Polling Loop (short circuit)
992, 995 – 999	Duress and Keypad Panics	992: Duress 995: 1 + * panic (A key) 996: 3 + # panic (C key) 999: * + # panic (B key)

Supervisory zones should be given a response type of either 05 (Trouble by Day, Alarm by Night) or 19 (24-Hour Trouble).

Communication Defaults

- | | | | | | | | |
|-----|-------------------------|-----|-------------------|-----|--|-----|----------------------------------|
| *45 | PRIMARY FORMAT | [1] | ADEMCO Contact ID | *51 | DUAL REPORTING | [0] | no |
| *46 | LOW SPEED FORMAT (Prim) | [0] | ADEMCO Low Speed | *52 | STANDARD/EXPANDED REPORT FOR PRIMARY | [0] | [0] [0] [0] [0] [0] [0] standard |
| *47 | SECONDARY FORMAT | [1] | ADEMCO Contact ID | | Alarm Rstr Bypass Trbl Opn/Cls Low Bat | | |
| *48 | LOW SPEED FORMAT (Sec.) | [0] | ADEMCO Low Speed | *53 | STANDARD/EXPANDED REPORT FOR SECONDARY | [0] | [0] [0] [0] [0] [0] [0] standard |
| *49 | CHECKSUM VERIFICATION | [0] | [0] | | Alarm Rstr Bypass Trbl Opn/Cls Low Bat | | |
| | No checksum | | Primary Secondary | | | | |
| *50 | SESCO/RADIONICS SEL. | [0] | Radionics | | | | |

Communication Defaults for Zones

ZONE #	1st	2nd	ZONE #	1st	2nd
001	01	00	601-632	00	00
002	02	00	800-830	00	00
003	03	00	970	00	00
004	04	00	988	00	00
005	05	00	990	00	00
006	06	00	992 (DURESS)	11	00
007	07	00	995	01	00
008	08	00	996	02	00
009	09	00	997	06	00
010	10	00	999	03	00
011	11	00	ALARM RST.	01	00
012	12	00	TROUBLE	01	00
013	13	00	TRBLE. RST	01	00
014	14	00	BYPASS	01	00
015	15	00	BYP. RST.	01	00
016	01	00			
017	02	00			
018	03	00			
019	04	00			
020	05	00			
021	06	00			
022	07	00			
023	08	00			
024	09	00			
025	10	00			
026	11	00			
027	12	00			
028	13	00			
029	14	00			
030	15	00			
031	05	00			
032	06	00			

Zone Response Type Definitions

Each zone must be assigned a zone type, which defines the way in which the system responds to faults in that zone. There are three keypad-activated zones (panic keys; see note) for each partition, a polling loop supervision zone, and four RF supervisory zones, two

for each RF receiver installed. Zone types are defined below.

Type 00: Zone Not Used

Program with this zone type if the zone is not used.

Type 01: Entry/Exit #1 Burglary

Provides entry delay whenever the zone is faulted and the system is armed in the AWAY or STAY mode. When the panel is armed in the INSTANT or MAXIMUM mode, no entry delay is provided. Exit delay begins whenever the control is armed, regardless of the arming mode selected. These delays are programmable.

Assign this zone type to zones that are used for primary entry to and exit from the facility.

Type 02: Entry/Exit #2 Burglary

Provides a secondary entry delay, if the system is armed in the AWAY or STAY modes and the zone is faulted. When the panel is armed in the INSTANT or MAXIMUM mode, no entry delay is provided. Secondary exit delay begins whenever the control is armed, regardless of the arming mode selected. These delays are programmable.

Assign this zone type to zones that are used for entry and exit of the facility and require more time than the primary entry and exit point. Delay times for this zone type must be greater than those for zone type 01 (e.g., a garage, loading dock, or basement door).

Type 03: Perimeter Burglary

Provides an instant alarm if the zone is faulted and the system is armed in the AWAY, STAY, INSTANT, or MAXIMUM mode.

Assign this zone type to all exterior doors and windows.

Type 04: Interior, Follower

Provides a delayed alarm (using the programmed entry delay time) if an entry/exit zone is faulted first. Otherwise it produces an instant alarm. It is active when the system is armed in the AWAY or MAXIMUM mode, but the MAXIMUM mode eliminates the entry delay.

Interior Follower zones are automatically bypassed when the panel is armed in the STAY or INSTANT mode.

Assign this zone type to a zone covering an area such as a foyer, lobby, or hallway through which one must pass upon entry or exit (to and from the keypad).

Type 05: Trouble by Day/Alarm by Night

Provides an instant alarm if the zone is faulted and the system is armed in the AWAY, STAY, INSTANT, or MAXIMUM mode. During the disarmed state (day), the system annunciates a latched trouble sounding from the keypad (and a central station report, if desired).

Assign this zone type to a zone that contains a foil-protected door or window (such as in a store), or to a zone covering a sensitive area such as a stock room or drug supply room. It can also be used on a zone in an area where immediate notification of an entry is desired.

Type 06: 24-Hour Silent Alarm

Sends a report to the central station but provides no keypad display or sounding. Assign this zone type to a zone containing an Emergency button.

Type 07: 24-Hour Audible Alarm

Sends a report to the central station and provides an alarm sound at the keypad and an audible external alarm. Assign this zone type to a zone containing an Emergency button.

Type 08: 24-Hour Auxiliary Alarm

Sends a report to central station and provides an alarm sound at the keypad only. **(No other Notification Appliance Circuit is activated.)** Assign this zone type to a zone an Emergency button or one containing monitoring devices such as water sensors or temperature sensors.

Type 09: Supervised Fire (Without Verification)

Provides a fire alarm on a short circuit and a trouble condition on open circuit. A fire alarm produces a pulsing of the Notification Appliance Circuit. This type is always active and can only be bypassed by the Installer code or Master code, (field 3*85).

Type 10: Interior with Delay

Provides entry and exit delays (using the programmed entry and exit delay times) when armed in the AWAY mode. Delay begins whenever sensors in this zone are violated, regardless of whether or not an entry/exit delay zone was tripped first. Provides only exit delay when armed in the MAXIMUM mode (no entry delay). Interior with Delay zones are automatically bypassed when the panel is armed in the STAY or INSTANT mode.

Assign this zone type to a zone covering an area such as a foyer, lobby, or hallway through which one must pass upon entry or exit (to and from the keypad).

Type 13: Remote P/S

Sends a report to the central station upon detection of an AC power loss on a power supply following the parameters selected in *19 (Randomize AC Loss Report). The exception being that if option 3 is selected for *19, 6- 12 hour reporting will not be used. Instead if option 3 is selected, reporting will be 1-3 hours, the same as if option 2 were selected.

Type 14: CO Detector Alarm

Sends a report to the central station and displays a CO text message at the keyboard. Upon a CO alarm only the keypad's sounder will annunciate. The external bell will not sound at all.

Type 16: Fire with Verification

Provides a fire alarm when there is a short circuit and a trouble condition when there is an open circuit. An initial short results in a 7-second smoke detector power reset. Any subsequent short within 90 seconds causes a fire alarm. This type is always active and can only be bypassed by the Installer code or the Master code, (field 3*85).

Type 17: Fire Waterflow

Provides a trouble condition on open circuit and an alarm on a short circuit that remains longer than the programmed time delay (fields 3*16 and 3*18). The alarm can be silenced by either an entry of **User Code + OFF** or when the zone restores (field 3*14). This type is always active and can only be bypassed by the Installer code or the Master code, (field 3*85).

Type 18: Fire Supervisory

Provides a supervisory response on a short circuit. Open circuit can be programmed for either a trouble or supervisory response (field 3*13). This type is always active and can only be bypassed by the Installer code or the Master code, (field 3*85).

Type 19: 24-Hour Trouble

Provides a trouble response on a short or open circuit. No alarm sounders are activated.

Type 20: Arm-STAY (5800 Series devices only)

Causes the system to arm in the STAY mode when the zone is activated.

Type 21: Arm-AWAY (5800 Series devices only)

Causes the system to arm in the AWAY mode when the zone is activated.

Type 22: Disarm (5800 Series devices only)

Causes the system to disarm when the zone is activated.

Type 23: No Alarm Response

Used on a zone when an output relay action is desired, but with no accompanying alarm (e.g., for lobby door access).

Type 27: Access Point – Not Used**Type 28: Main Logic Board (MLB) Supervision – Not Used****Type 29: Momentary Exit – Not Used**

NOTE FOR PANIC KEYS: Keypad panic zones share the same zone response type for both partitions, but panics may be individually enabled for each partition.

IMPORTANT! FAULT ANNUNCIATION

Polling loop and RF troubles (zones 988, 990, and 997) report as trouble conditions only, and as such, should be assigned zone type 19 if annunciation is desired. See *Polling Loop Supervision* and *RF System Operation and Supervision* in *SECTION 3: Installing the Control* for more information.

Zone Input Type Definitions

Each zone must be assigned an input type, which defines the where the system will “look” for status of the zone (RF receiver, polling loop, etc.). Zone input types are defined below.

Type 01 Hardwired (HW)

Reserved for the built-in hardwired zones 001-008.

Type 03 Supervised RF (RF)

Select for 5800 Series transmitters that will be supervised for check-in signals. The transmitter must remain within the receiver’s range.

Type 04 Unsupervised RF (UR)

Select for 5800 Series transmitters that will not be supervised for check-in signals. The transmitter may therefore be carried off-premises.

Type 05 Unsupervised Button RF (BR)

Select for 5800 Series transmitters specifically designed for this input type. These transmitters send only fault signals. They do not send low-battery signals until they

are activated. The transmitter may be carried off-premises.

Type 06 Serial Number Polling Loop (SL)

Use for V-Plex devices with a built-in serial number.

Type 07 DIP Switch Loop (DP)

Select for polling loop devices that use DIP switches for programming the zone number of the device.

Type 08 Dip Switch Polling Loop Right Loop (PS)

Select for the second loop of two-zone polling loop devices (e.g., 4190SN).

Type 09 Console Input (CS)

Select when this zone is to be controlled by a keypad input (user code + [#] + [7] + [3]) for access control.

Type 10 PassPoint Access Control (ACS) – Not Used**Type 11 VistaKey Door Status Monitor (DSM) – Not Used****Type 12 VistaKey Request to Exit (RTE) – Not Used****Type 13 VistaKey General Purpose (GP) – Not Used**

Using the a Relay to Unlock A Door

This control can be programmed so that a user can trigger a relay for 2 seconds (e.g., to unlock a door) by entering the User Code + [0].

To program a relay for this purpose, perform the following steps::

Step	Action
1	Enter Output Programming in the #93 Menu Mode.

Step	Action
2	Program the output type as 1, or 2.
3	For type 1, program the ECP address and relay number.
4	For type 2, program the house and unit codes.
5	Program the relay number in field 1*76 (partition-specific).

See *Output Programming in the Programming Guide* for a detailed explanation.

Programming for ECP Communications Device

- Program the Communications Device in *Device Programming* in the #93 Menu Mode Programming.
- Program field *56: Selects the time the panel should wait before it attempts to send a message to the second destination..
- Program field *57: Selects the initial reporting destination for messages.
- Program field *58: Selects events for the primary sub's ID
- Program field *59: Selects events for the secondary sub's ID.

Programming for the Event Log

- Program field 1*70 Event Log Types (1=enable; 0=disable for each type)
- Program field 1*71 12/24-Hour Time Stamp Format (0=12 hr; 1=24 hr)
- Program field 1*72 Event Log Printer On-line (0=disable; 1=enable)
- Program field 1*73 Printer Baud Rate (1=300; 0=1200)

Data Field Descriptions

About Data Field Programming

The following pages list this control's data fields in numerical order. Field numbers are listed in the left column, followed by a "Title and Data Entries" column, which lists the valid entries for each field. Experienced installers can simply follow this column when programming the data fields. The "Explanation" column provides explanatory information and special notes where applicable.

NOTE: Refer to the *Programming Guide* for the default values. They are not listed in this section.



Use the *Programming Guide* to record the data for this installation.

Programming Data Fields

Data field programming involves making the appropriate entries for each of the data fields. Start Data Field programming by entering the installer code + 8 + 0 + 0.



All Fire zones should be assigned to partition 1.

FIELD	TITLE and DATA ENTRIES	EXPLANATION
*00	Installer Code Enter 4 digits, 0-9	The Installer Code is a 4-digit code reserved for installation company use. This is the only code that can be used to enter the Program Mode from the keypad. This code cannot be used to disarm the system if it isn't used to arm the system. This code cannot be used to re-enter Program Mode if Program Mode is exited by the *98 command.
*08	Temporal Siren Pulse	Not use at this time.
*09	Entry Delay #1 (partition-specific) Enter 02-15 multiplied by 15 seconds. 00 = no delay.	Entry delay defines the delay time that allows users to re-enter the premises through a door that has been programmed as an entry delay door and disarm the system without sounding an alarm. The system must be disarmed within this period or an alarm will occur. NOTE: The delay may not exceed 45 seconds for UL installations.
*10	Exit Delay #1 (partition-specific) Enter 03-15 multiplied by 15 seconds. 00 = no delay.	Exit delay defines the delay period that allows users to leave the premises through a door that has been programmed as an entry/exit delay door after arming the system without setting off the alarm.
*11	Entry Delay #2 (partition-specific) Enter 02-15 multiplied by 15 seconds. 00 = no delay.	Entry Delay #2 is used for a secondary door requiring a longer delay than those assigned to Entry Delay #1. NOTE: The delay may not exceed 45 seconds for UL installations
*12	Exit Delay #2 (partition-specific) Enter 03-15 multiplied by 15 seconds. 00 = no delay.	Exit Delay #2 is used for a secondary door requiring a longer delay than those assigned to Exit Delay #1. NOTE: The delay may not exceed 60 seconds for UL installations.

FIELD	TITLE and DATA ENTRIES	EXPLANATION
*13	Bell 1 Timeout Enter 01-15 multiplied by 2 minutes. 00 = no timeout.	Defines the length of time the Bell 1 Output and the keypad's sounder will sound for all audible alarms. Must be a minimum of 16 minutes for UL commercial burglary installations and a minimum 6 minutes for Commercial Fire installations.
*15	Keyswitch Assignment Enter 1-2 partition keyswitch is being used. Enter 3 if the keyswitch is being used to silence fire Notification Appliance Circuits in the event of a fire alarm. Enter 0 if the keyswitch is not used.	The keyswitch requires the use of zone 7 wired loop (zone 7 is no longer available as protection zone). The fire and panic alarm voltage triggers (J2) automatically become ARMING and READY status outputs for the Keyswitch LEDs. Openings/closing report as user "0" if enabled in field *40.
*16	Bell 1 Confirmation of Arming Ding (partition-specific) 0 = disable 1 = enable	If enabled, produces ½-second external alarm sounding ("ding") at the end of exit delay (or after kissoff from the central station, if sending closing reports). NOTE: If using a keyfob, when the button is pressed, either for arming or disarming, the bell will ding indicating that the button is working. Must be 1 for UL commercial burglary installations.
*17	AC Loss Keypad Sounding 0 = disable 1 = enable	If enabled, sounding at the keypad (rapid beeping) occurs when AC power is lost (sounding occurs about 2 minutes after actual AC loss). Must be 1 for Commercial Fire installations.
*19	Randomize AC Loss Report 0 = within 2 minutes 1 = 10-40 minutes 2 = 1-3 hours 3 = 6-12 hours without Type 13, 1-3 hours with Type 13	If enabled, randomizes AC loss reporting within the selected time after an actual AC loss. If disabled (0), AC loss reporting about 2 minutes after actual AC loss. Selecting this option helps prevent an overload of AC loss messages at the central station during a community blackout. Must be 2 for Commercial Fire installations.
*20	VIP Module Phone Code 01-09 = first digit of access code * or # = second digit of access code (enter 11 for "*", or 12 for "#") To disable enter 00 for the 1 st digit	If a 4286 Voice Module is being used, enter the 2-digit phone code used to access the system. Must be set to "00" for Commercial Fire and Commercial Burglary installations.
*22	Keypad Panic Enables (partition-specific) 0 = disable 1 = enable	If enabled, the keypad panics (zones 995, 996, and 999) may be used in this partition. There are three entries in this field, one for each panic. Do not use on partition 1 on fire systems.
*23	Multiple Alarms (partition-specific) 0 = disable 1 = enable	If enabled, allows more than one alarm sounding for a given zone during an armed period. NOTE: that multiple alarm soundings will not occur more frequently than allowed by the programmed alarm sounder duration. This has no impact on the number of communication messages transmitted. Must be 1 for Commercial Fire and UL Commercial Burglary installations.
*24	Ignore Expansion Zone Tamper 0 = disable (tamper detection) 1 = enable (no tamper detection)	If disabled, the system monitors the tampers on expansion zones. NOTE: Only applicable to certain polling loop sensors with tamper switches or 5800 Series transmitters. Must be 0 for UL installations.
*25	Burglary Trigger for Response Type 8 0 = disable 1 = enable	If enabled, allows triggering of the voltage output 3 on Pin 3 of the J2 header to include zone response type 8 (24-hr. auxiliary).
*26	Intelligent Test Report 0 = disable 1 = enable	If enabled, no test report is sent if any other type of report was sent since the last test report. If disabled, test reports are sent at the set intervals, regardless of whether or not any other report has been sent. Must be 0 for Commercial Fire and UL Commercial Burglary installations.

FIELD	TITLE and DATA ENTRIES	EXPLANATION
*27	Test Report Interval Enter 001-999 for the test report interval in hours. Enter 000 for test reporting.	If a test report is desired, enter a test code in <i>Report Code Programming</i> in <i>#93 Menu Mode</i> . Set first test report time in field *83. Maximum Test report interval is 024 for Commercial Fire and UL Commercial Burglary installations.
*28	Power-Up in Previous State 0 = disable 1 = enable	If enabled, the system, upon power-up, reverts to its status prior to a complete power loss. If disabled, the system always powers up in a disarmed state. NOTES: Neither authority level 0 nor 5 can be used to disarm the system if the control powers up armed. When Power Up in Previous State is enabled, if the panel powers up armed, it may take up to 3 minutes before an alarm is recognized and initiated. Must be 1 for UL applications.
*29	Quick Arm (partition-specific) 0 = disable 1 = enable	If enabled, allows arming of the burglary system in AWAY, STAY, INSTANT, or MAXIMUM mode by using the [#] key instead of the user code. NOTES: When armed, the system reports closing as User 0 if Open/Close reporting for User #2 (typically a Master level user) was enabled for a given partition. If Quick Arm is used, the Installer Code and Authority Level 5 codes cannot disarm the system.
*30	Main Dialer TouchTone or Rotary Dial 0 = rotary 1 = touchtone 	Select the dialing method for the main dialer. If you select TouchTone, make sure the subscriber has requested and is paying for TouchTone service. Note that whether or not TouchTone dialing for call placement is permitted, communication by the use of DTMF signaling (ADEMCO High Speed) will still take place. See field 1*33 for TouchTone w/Rotary backup
*31	PABX Access Code Enter 00-09; B-F (11-15)	This field is used to enter up to four 2-digit numbers representing the prefix needed to obtain an outside telco line. If not required, enter nothing and proceed to next field.
*32	Primary Subscriber's Account Number (partition-specific) Enter 00-09; B-F (11-15)	Enter a 3- or 4-digit (depending on report format) primary subscriber account number. Each number requires a 2-digit entry so as to allow entry of hexadecimal digits (B-F). If a 3-digit account number is to be used, enter data only in the first three locations, and enter * in the fourth location.
*33	Primary Phone Number Enter 0-9; #11 for *, #12 for #, #13 for a 2-second pause.	Enter the primary central station phone number, up to 17 digits. This is the phone number the control will use to transmit Alarm and status messages to the central station. Do not fill unused spaces. NOTE: Backup reporting is automatic only if a secondary phone number is entered.
*34	Secondary Phone Number Enter 0-9; #11 for *, #12 for #, #13 for a 2-second pause.	Enter the secondary phone number, up to 17 digits. The secondary phone number is used if communication on the primary number is unsuccessful, or if split/dual reporting is desired. Do not fill unused spaces. NOTE: If this field is programmed, a secondary subscriber account number (field *90) <i>must</i> also be programmed.
*35	Download Phone Number Enter 0-9; #11 for *, #12 for #, #13 for a 2-second pause.	Enter the downloading phone number, up to 17 digits. Do not fill unused spaces. NOTE: This field is applicable only if downloading is utilized.
*36	Download ID Number Make entries as 2-digit numbers as follows: 00=0 01=1 02=2 03=3 04=4 05=5 06=6 07=7 08=8 09=9 10=A 11=B 12=C 13=D 14=E 15=F	Enter eight digits. NOTE: This field is applicable only if downloading is utilized.

FIELD	TITLE and DATA ENTRIES	EXPLANATION
*37	Download Command Enables 0 = disable 1 = enable	Enabling a function means that you are able to perform that function via the ADEMCO Compass Downloading software. Functions are as follows: Dialer Shutdown; System Shutdown; Not Used; Remote Bypass; Remote Disarm; Remote Arm; Upload Program; and Download Program. For UL Commercial Burglary and Fire installations, all entries must be 0 .
*38	Prevent Zone XXX Bypass (partition-specific) Enter a zone number (001-032). Enter 000 if all zones can be bypassed.	Enter three digits for zone that cannot be bypassed by the user. NOTES: The actions manual bypass and STAY/INSTANT arming modes cannot bypass any zone programmed in this field.
*39	Enable Open/Close Report for Installer Code (partition-specific) 0 = disable 1 = enable	If enabled, whenever the Installer Code is used to arm or disarm the partition, an open/close report is sent to the central station.
*40	Enable Open/Close report for Keyswitch 0 = disable 1 = enable	If enabled, whenever the keyswitch is used to arm or disarm the partition, an open/close report is sent to the central station.
*41	Normally Closed or EOLR (Zones 003-008) 0 = EOLR supervision 1 = N.C. loops	If EOLR supervision is selected, end-of-line resistors must be used on zones 003-008. If N.C. loops is selected, end-of-line resistors cannot be used and only normally closed devices must be used. Must be set to "0" for Commercial Fire and Burglary installations.
*42	Dial Tone Pause Enter the wait time for dial tone detection: 0 = 5 seconds; 1 = 11 seconds; 2 = 30 seconds.	Enter the time the system waits for dial tone before dialing. Applies if true dial tone is not selected in field *43. Must be 0 for UL installations.
*43	Dial Tone Detection 0 = disable 1 = enable	If enabled, the system waits for true dial tone. If no dial tone is detected, control dials at end of pause programmed in field *42. If disabled, the system pauses for seconds entered in field *42, then dials. NOTE: Disabling may be necessary in high-noise environment telco networks where noise can be confused with dial tone, resulting in premature dialing.
*44	Ring Detection Count Enter 00 to disable ring detection. Enter 01-14 for ring counts of 1-14. Enter 15 to select Answering Machine Defeat Mode	NOTES: In the Answering Machine Mode, the caller should let the phone ring once, then hang up, and call again within 30 seconds. The system, upon hearing one ring followed by nothing, does not answer the first call, but readies itself to pick up on the first ring of the next incoming call that is received within 30 seconds (i.e., the downloader calling again). Must be 00 for Commercial Fire and Burglary installations.
*45	Primary Format 0=Low Speed; 1=Contact ID; 2=ADEMCO High Speed; 3=ADEMCO Express	Enter the reporting format for the primary telephone number.
*46	Low Speed Format (Primary) 0 = ADEMCO Low Speed 1 = Sescoa/Radionics	Enter the low speed format for the primary telephone number.
*47	Secondary Format 0=Low Speed; 1=Contact ID; 2=ADEMCO High Speed; 3=ADEMCO Express	Enter the reporting format for the secondary telephone number.

FIELD	TITLE and DATA ENTRIES	EXPLANATION
*48	Low Speed Format (Secondary) 0 = ADEMCO Low Speed 1 = SESCOA/Radionics	Enter the low speed format for the secondary telephone number.
*49	Checksum Verification Enter two digits, one for the primary and one for the secondary. 0 = disable 1 = enable	If enabled, the system for either or both primary/secondary formats sends a verification digit to validate the message at the receiver without having to send two message rounds. Selection is valid for 3+1, 4+1, and 4+2 reports.
*50	SESCOA/Radionics Select 0 = disable 1 = enable	If disabled, selects Radionics, which uses hexadecimal 0-9, B-F reporting. If enabled, selects SESCOA, which uses only numeric reporting (0-9). NOTE: The selection applies to both primary and secondary phone numbers.
*51	Dual Reporting 0 = disable 1 = enable	If enabled, all reports are to be sent to both primary and secondary phone numbers. This is required for line security in UL1610/365 installations. NOTE: If used with Split Reporting "1" option (1*34), alarms and alarm restores go to both primary and secondary numbers, while all other reports go to secondary only. If used with Split Reporting "2" option, alarms and alarm restores go to both, open/close and test messages go to secondary only, while all other reports go to primary. If used with Split Reporting "3" option, fire alarms and fire restore signals go to both, all other reports go to secondary only. NOTE: For Remote Station Applications, where separate transmission circuits are required for Fire, Supervisory (when applicable) and Trouble signals, Split Reporting, option 3, must be enabled.
*52	Standard/Expanded Reporting Primary 0 = disable 1 = enable	This field has six entries as follows: Alarm, Restore, Bypass, Trouble, Open/Close, Low Battery. If enabled, expanded reports are sent to the primary phone number if low speed format is selected in field *45. NOTE: Expanded overrides 4+2 format.
*53	Standard/Expanded Reporting Secondary 0 = disable 1 = enable	This field has six entries as follows: Alarm, Restore, Bypass, Trouble, Open/Close, Low Battery. If enabled, expanded reports are sent to the secondary phone number if low speed format is selected in field *47. NOTE: Expanded overrides 4+2 format.
*56	Dynamic Signaling Delay Enter 00-15 times 15 seconds.	Select the time the panel should wait for acknowledgment from the first reporting destination before it attempts to send a message to the second destination (first and second destinations are determined in field *57). NOTES: A minimum of 45 seconds is recommended when the Communicator is set to be the primary report path. If the delay were short (30 seconds or less), the Communications Device does not have enough time to send the acknowledgement back to the panel, therefore the report would be sent out via the dialer. If the acknowledgment is received before the delay time expires, no message is sent to the second destination.
*57	Dynamic Signaling Priority 0 = Primary Dialer 1 = Communicator	Select the initial reporting path for central station messages.
*58	Communicator Central Station #1 Category Enable 0 = disable 1 = enable	This field has six entries as follows: Alarm, Trouble, Bypass, Open/Close, System, and Test. If enabled, the reports are sent to the primary subscriber ID of the Communicator.
*59	Communicator Central Station #2 Category Enable 0 = disable 1 = enable	This field has six entries as follows: Alarm, Trouble, Bypass, Open/Close, System, and Test. If enabled, the reports are sent to the secondary subscriber ID of the Communicator.

FIELD	TITLE and DATA ENTRIES	EXPLANATION
*64	Alpha Numeric Pager Installed	Not Used. Must be set to "0".
*65	Pager Phone Number for Alarms	Not Used. Must be set to "0".
*66	Pager ID Number for Alarms	Not Used. Must be set to "0".
*67	Pager Phone Number for Supervision	Not Used. Must be set to "0".
*68	Pager ID Number for Supervision	Not Used. Must be set to "0".
*69	Pager Phone Number for Bypasses	Not Used. Must be set to "0".
*70	Pager ID Number for Bypasses	Not Used. Must be set to "0".
*71	Pager Phone Number for Opens/Closes	Not Used. Must be set to "0".
*72	Pager ID Number for Open/Closes	Not Used. Must be set to "0".
*73	Pager Phone Number for System	Not Used. Must be set to "0".
*74	Pager ID Number for System	Not Used. Must be set to "0".
*75	Pager Phone Number for Test	Not Used. Must be set to "0".
*76	Pager ID Number for Test	Not Used. Must be set to "0".
*77	Auto Restore 0 = disable 1 = restore troubles only 2 = restore troubles and fire alarms	If set to 0 (disable), the operation is that restore reports will be sent to the CS when the actual restoral on the zone occurs, however the keypad display will remain showing the condition until a valid code is entered. If set to 1 (restore troubles only), each trouble and supervisory condition automatically clears the keypad display and stops the keypad beeping when the zone returns to a "ready/normal" state. This applies to ALL trouble and supervisory types. The system also sends the Trouble/Supervisory Restore report to the central station, if programmed. If a partition has more than one trouble/supervisory condition present at the same time, the system automatically clears the keypad display of each zone as it restores, but the keypad continues to beep until all the zones restore. If set to 2 (restore troubles and fire alarms), silences and restores the keypad when a trouble or fire alarm restores. If there are multiple alarms, it will only restore when all zones are restored. NOTES: Must be set to "1" for Commercial Fire installations. Option 2 is ONLY for use if the system is used as a slave communicator only, and NOT if the system is used for Fire Alarm Detection.
*79	Zone Type Restores for Zone Types 1-8 0 = disable 1 = enable	This field has eight entries, one for each zone type. Select the zone types that will send Restore reports.

FIELD	TITLE and DATA ENTRIES	EXPLANATION
*80	Zone Type Restores for Zone Types 9, 10 & 14 0 = disable 1 = enable	This field has three entries, one for each zone type. Select the zone types that will send Restore reports. Restores must be set to "1" for Commercial Fire installations.
*83	First Test Report Time Enter 00-07 the for day (01 = Monday) Enter 00-23 for the hour Enter 00-59 for the minutes	Enter the day and time that the first Test report shall be transmitted. Enter 00 in all locations if the Test report is to be sent immediately upon exiting. Enter 00 in the day location if the report is to be sent at the next occurrence of the time that is set.
*84	Swinger Suppression (partition-specific) Enter 01-15. Enter 00 for unlimited reports	This option limits the number of messages (alarms or troubles) sent for a specific zone in an armed period. The system automatically resets the shutdown for a zone after 48 hours if there are no trips on any zone. Must be 00 for Commercial Fire and Burglary installations.
*85	Enable Dialer Reports for Panics & Duress (partition-specific) 0 = disable 1 = enable	This field has four entries as follows: Zone 995, 996, 999, and Duress Enable for each partition that the panics and duress reporting is desired. NOTE: Non-zero report code must be assigned to zone 992 (duress) to enable Duress reporting.
*87	Entry Warning (partition-specific) 0 = 3 short beeps 1 = slow continuous beeps	Select the type of warning for the entry delay period.
*88	Burglary Alarm Communicator Delay (partition-specific) 0 = no delay 1 = 16-second delay	Select the delay, if any, for burglary alarm communications. Must be 0 for UL installations.
*89	Alarm Restore Report Timing 0=Instant – will send upon disarm or if zone is restored. 1=Restore is sent at bell timeout if zone is restored, if not it is sent at disarm 2=Restore is sent at disarm whether the zone is restored or not.	Select the time when restore reports are sent after an alarm. This field applies only to Burglary zone types. It does not apply to Fire or Panic zone types. Must be set to "2" for Commercial Burglary installations.
*90	Secondary Subscriber Account Number (partition-specific) Enter 00-09; B-F (11-15)	Enter a 3- or 4-digit (depending on report format) primary subscriber account number. Each number requires a 2-digit entry so as to allow entry of hexadecimal digits (B-F). If a 3-digit account number is to be used, enter data only in the first three locations, and enter * in the fourth location. NOTE: This field <i>must</i> be programmed if a secondary phone number is used (field *34). This account number can be the same as the primary account number.
1*12	Program Notification Signal 0 = no 1 = yes	If enabled, sends signal to central station indicating the system has been put in programming mode. Must be 1 for Commercial Fire installations.
1*13	System Sensor Reversing Relay 0 =use neither Zone 1 or Zone 2 inputs 1=use Zone 1 input; 2=use Zone 2 input; 3=use Zone 1 and Zone 2 inputs.	Selects zones for system sensor reversing relay. Not Used.
1*17	Lobby Partition 0 = none 1-2 = partition number	Select the Common Lobby Partition.

FIELD	TITLE and DATA ENTRIES	EXPLANATION
1*18	Affects Lobby (partition-specific) 0 = disable 1 = enable	If enabled, causes lobby partition to disarm when this partition disarms. NOTE: This partition must be armed before lobby can be armed. Must be set to "0" (disable) for partition 1.
1*19	Arms Lobby (partition-specific) 0 = disable 1 = enable	If enabled, arming this partition causes the system to attempt to arm the lobby partition. Field, field 1*18 must also be enabled (partition-specific). NOTES: The lobby cannot be armed unless all partitions programmed for "affect" (field 1*18) is already armed. If his field is enabled, Field 1*18 for this partition must also be enabled. Must be set to "0" (disable) for partition 1.
1*20	Exit Error Logic Enable 0 = disable 1 = enable	If enabled, the system at the end of exit delay, if an entry door or an interior zone is left open, starts the entry delay period, and activates the Notification Appliance Circuit(s) and keypad sounders for the duration of entry delay. This gives the user time to re-enter the premises and disarm the system before exit error occurs. If the user does not re-enter the premises and disarm the system, the system bypasses the faulted entry/exit and/or interior zone(s). The rest of the system is armed. Also, the following dialer reports are sent to the central station if programmed: Exit Error by User (not sent when is using ADEMCO High Speed format); Entry/Exit or Interior Alarm with the zone number; Bypass reports.
UL Exit Error Logic is not suitable for use in a UL installation (must be 0).		
1*21	Exit Delay Reset 0 = disable 1 = enable	If enabled, when the panel is armed, the normal exit delay begins. After the user exits, closes the door and then re-enters the premises, the exit delay time is reset to the programmed value. NOTES: Exit Delay Reset is designed to allow an operator to re-enter the premises to retrieve a forgotten item without triggering an alarm. This feature may only be activated once after arming.
UL Exit Delay Reset is not suitable for use in a UL installation (must be 0).		

Cross-Zoning

UL Cross Zoning is not suitable for use in a UL installation.

Cross Zoning is designed so that a combination of two zones must be faulted within a 5-minute period of each other (whereas the first zone remains faulted, when the second zone trips) to cause an alarm on either zone. This prevents momentary faults from either of the zones from causing an alarm condition. You can select four "sets" of cross-zones (programmed in data fields 1*22, 1*23, 1*24, and 1*25), keeping in mind the following:

- Both zones in each set must protect the same area.
- Both zones in each set must be in the same partition.

Conditions That Affect Cross-Zone Operation

- In the event of a continuous fault (lasting at least 5 minutes) on one of the paired zones, a fault on the second zone causes an alarm immediately.
- If one of the zones in a pair is bypassed or has a zone response type set to 0, the cross-zoning feature does not apply.
- If an entry/exit zone is paired with an interior follower zone, be sure to enter the entry/exit zone as the first zone of the pair. This ensures that the entry delay time is started before the follower zone is processed.
- If a relay is programmed to activate on a fault of one of the zones, the relay activates without the other zone being faulted.
- If a relay is programmed to activate on an alarm or trouble, both zones must trip before the relay activates, and both zones must restore for the relay to deactivate (if relay is programmed to deactivate on a Zone List Restore).



If the one of the zones trips and the second zone does not trip within the 5-minute period, an "error" message is reported to the central station. The Contact ID event code is 378.

FIELD	TITLE and DATA ENTRIES	EXPLANATION
1*22	Cross Zoning Pair One Enter 001-032 Enter 000,000 to disable	Select the first pair of cross zones, which must both be faulted within a 5-minute period to cause an alarm. Must be set to 000,000 for Commercial Fire and Burglary installations.
1*23	Cross Zoning Pair Two Enter 001-032 Enter 000,000 to disable	Select the second pair of cross zones, which must both be faulted within a 5-minute period to cause an alarm. Must be set to 000,000 for Commercial Fire and Burglary installations.
1*24	Cross Zoning Pair Three Enter 001-032 Enter 000,000 to disable	Select the third pair of cross zones, which must both be faulted within a 5-minute period to cause an alarm. Must be set to 000,000 for Commercial Fire and Burglary installations.
1*25	Cross Zoning Pair Four Enter 001-032 Enter 000,000 to disable	Select the fourth pair of cross zones, which must both be faulted within a 5-minute period to cause an alarm. Must be set to 000,000 for Commercial Fire and Burglary installations.
1*26	Panic Button or Speedkey For A, B, C keys: 00 = panic function 01-32 = macro number For D key: 00 = to select a macro to execute when key is pressed 01-32 = macro number	Select for the A, B, and C keys whether the system performs a panic or a speedkey function when the key is pressed. Select for the D key whether the system performs a specific macro or if the user will select a macro when the key is pressed.
1*28	RF Transmitter Low Battery Sound 0 = disarmed state only 1 = both armed and disarmed states	Select when the RF transmitter low-battery condition should display and audible beep annunciate on the keypad. Must be 1 for Commercial Fire and UL Commercial Burglary installations.
1*29	RF Transmitter Low Battery Reporting 0 = disable 1 = enable	If enabled, the system sends a Trouble message for RF transmitter low-battery condition to the central station. NOTE: The Trouble message will be sent for a transmitter supervision failure, independent of this selection. Must be 1 for Commercial Fire and UL Commercial Burglary installations.
1*30	RF Receiver Supervision Check-in Interval Enter 02-15 times 2 hours (4-30 hours). 00 = disable receiver supervision.	Select the check-in monitoring interval for the RF receiver(s). Failure of a receiver to receive any RF signal within the time entered results in the activation of the response type programmed for zone 990 for the first receiver and zone 988 for the second receiver and their related communication reports. Maximum is 2 (4 hr) for Commercial Fire and UL Commercial Burglary installations.
1*31	RF Transmitter Check-in Interval Enter 02-15 times 2 hours (4-30 hours). 00 = disable transmitter supervision.	Select the check-in monitoring interval for the RF transmitters. Failure of an individual transmitter to send a supervision signal within the time entered will result in a trouble response and related communication report. Maximum is 2 (4 hr) for Commercial Fire and UL Commercial Burglary installations.
1*33	TouchTone with Rotary Backup 0 = disable 1 = enable	If enabled, the system reverts to rotary dialing if communicator is not successful in dialing using TouchTone DTMF on first attempt.
1*34	Communicator Split Reporting 0 = Split Reporting disabled 1 = Alarm, Alarm Restore, and Cancel reports to primary, all others to secondary 2 = Open/Close and Test reports to secondary, all other reports to primary 3 = Fire Alarms and Fire Restores to primary, all others to secondary	Select the type of split reporting for system communication. NOTE: See *51 for split/dual reporting combinations. NOTE: Split reporting should not be used with Dynamic Signaling.

FIELD	TITLE and DATA ENTRIES	EXPLANATION
1*35	Access Control Dialer Enables 0 = disable 1 = enable	There are six entries for this field as follows: Trace, Trouble, Not Used, Bypass, System, and Alarm. If Trace is enabled, access grant/denial events sent to the central station. For the other events, if enabled, a report is sent to the central station. Not Used.
1*42	Call Waiting Defeat 0 = disable 1 = enable	If enabled, the system defeats Call Waiting on the first outgoing call attempt to both the primary and secondary numbers. NOTES: After the panel's initial call to report the alarm, the panel may attempt to make an additional call, perhaps for a cancel or a zone restoral. If Call Waiting is not defeated, an operator at the central station attempting to contact the premises (to verify whether the alarm is valid) hears the phone ringing indefinitely and must to dispatch on the call. DO NOT enable this feature unless Call Waiting is being used.
1*43	Permanent Keypad Display Backlighting (partition-specific) 0 = disable 1 = enable	If enabled, backlighting for the keypad display remains on at all times. Otherwise the backlighting comes on when a key is pressed. NOTE: When a key is pressed, display backlighting turns on for all keypads in that partition.
1*44	Wireless Keypad Tamper Detect 0 = disable 1 = enable	If enabled, when more than 40 key depressions are received without a valid sequence (arm, disarm, etc.), the control panel disables the wireless keypad. The inhibit is removed once a valid key sequence is received from a wired keypad. Not Used. Must be disabled ("0").
1*45	Exit Delay Sounding (partition-specific) 0 = disable 1 = enable	If enabled, the system produces slow beeping from the keypads during exit delay and reverts to rapid beeping during the last 10 seconds of the exit delay. NOTES: The duration of the beeping is the programmed value of field *10 regardless of which entry/exit zone is used to exit the premises. See page 32 in the Programming Guide, "SOUND OPTION", prompt for disabling the entry/exit beeps on the individual keypads.
1*47	Chime on Bell 1 (partition-specific) 0 = disable 1 = enable	If enabled, the system produces chime annunciation on the Bell 1 output.
1*48	Wireless Keypad Assignment 0 = none 1-2 = partition number	Select the partition in which RF keypad is used. Not Used. Must be disabled ("0").
1*49	Suppress Transmitter Supervision Sound 0 = disable 1 = enable	If enabled, no trouble soundings occur on the keypad for transmitter check-in failures. Must be 0 for UL installations.
1*52	Send Cancel If Alarm + Off (partition-specific) 0 = disable 1 = enable	If enabled, Cancel reports are sent when the system is disarmed after an alarm, regardless of how much time has gone by. If disabled, Cancel reports are sent within Bell Timeout period only. NOTE: This option must be enabled so Cancel reports are always sent.
1*53	Disable Download Callback 0 = callback required 1 = no callback required	Select whether a callback from the control panel is required for downloading. Must be 0 for commercial fire and burglary installations.
1*55	European Date Format 0 = disable (mm/dd/yy) 1 = enable (dd/mm/yy)	Select the date format for display in the event log.

FIELD	TITLE and DATA ENTRIES	EXPLANATION
1*56	AC 60Hz or 50Hz 0 = 60Hz 1 = 50Hz	Select the frequency for the AC. Must be set to 0 for U.S. and Canadian installations.
1*57	Enable 5800 RF Button Global Arm 0 = disable 1 = enable	If enabled, the system arms/disarms in accordance with the button's user's global-arming settings. Must be 0 for Commercial Fire and Commercial Burglary installations.
1*58	Enable 5800 RF Button Force Arm 0 = disable 1 = enable	If enabled, allows the RF button user to force a bypass of all faulted zones when arming the system. NOTE: When attempting to arm the system, the keypad beeps once after the button is pressed if any faulted zones are present. The user should then press the button again within 4 seconds to force-bypass those zones and arm the system.
1*60	Zone 5 Audio Alarm Verification 0 = disable 1 = enable	If enabled, zone 5 is used for 2-way audio (AAV). Must be 0 for commercial fire and burglary installations. NOTE: Zone 5 cannot be used as protection zone.
1*70	Event Log Types 0 = disable 1 = enable	This field has five entries as follows: Alarm, Check, Bypass, Open/Close, and System. If enabled, the system logs those events into the event log.
1*71	12/24 Hour Type Stamp Format 0 = 12-hour 1 = 24-hour	Select the type of time stamping for the event log.
1*72	Event Log Printer On-Line Mode 0 = disable 1 = enable	If enabled, the system prints the events as they occur. If disabled, the system prints the log only upon request.
1*73	Printer Baud Rate 0 = 1200 1 = 300	Select the baud rate for the serial printer. NOTE: Must be 1 if using the alphanumeric pager interface.
1*74	Relay Timeout XXX Minutes Enter 000-127 times 2 minutes (000-254).	This is used for #80 Menu Mode Time-Driven event relay command numbers "04/09" and <i>Output Programming</i> in the #93 Menu Mode Programming output command "56."
1*75	Relay Timeout YYY Seconds Enter 000-127 seconds.	This is used for #80 Menu Mode Time-Driven event relay command numbers "05/10" and <i>Output Programming</i> in the #93 Menu Mode Programming command "57."
1*76	Control Relay (partition-specific) 01-96 = relay number 00 = relay not used.	If enabled, the assigned relay closes for 2 seconds when the user enters his code and presses 0. Must be 00 for Commercial Fire and Burglary installations. NOTE: See <i>SECTION 3: Installing the Control</i> for enhanced access control capabilities.
1*77	Log First Maintenance Signal 0 = disable 1 = enable	If enabled, the system logs the first maintenance signal from each smoke detector. If disabled, no logging occurs.
2*00	Number of Partitions Enter 1-2.	Enter the number of partitions used in the system.
2*01	Daylight Saving Time Start/End Month 0 = disable 1 = enable	Enter the months (00-12) in which daylight saving time starts and ends. Enter 00, 00 if daylight saving time does not apply to the user's region. Standard setting for U.S. is 03, 11.

FIELD	TITLE and DATA ENTRIES	EXPLANATION
2*02	Daylight Saving Time Start/End Weekend 0 = disable 1 = enable	Enter the start and end weekends for daylight saving time as follows: 1=first; 2=second; 3=third; 4=fourth; 5=last; 6=next to last; 7=third from last. Standard setting for U.S. is 2, 1.
2*05	Auto-Arm Delay (partition-specific) 00 = no delay. 01-14 times 4 minutes (04-56) delay. 15 = no auto arming.	This is the time between the end of the arming window and the start of auto-arm warning time (field 2*06). NOTE: This field must be set to "00" for UL installations.
2*06	Auto-Arm Warning Period (partition-specific) 01-15 times 1-minute warning. 00 = no warning period.	This is the time that the user is warned by a keypad sounding and display to exit the premises prior to auto arming of the system. NOTE: This field must be set to "00" for UL installations.
2*07	Auto-Disarm Delay (partition-specific) 00 = no delay. 01-14 times 4 minutes (04-56) delay. 15 = no auto disarming.	This is the time between the end of the disarming window and the start of auto disarming of the system. NOTE: This field must be set to "15" for UL for UL864 compliance.
2*08	Force Arm Enable for Auto-Arm (partition-specific) 0 = disable 1 = enable	If enabled, the system automatically bypasses any faulted zones when it attempts to auto-arm. If disabled, the system will not auto-arm. NOTE: This field must be set to "0" for UL installations.
2*09	Open/Close Reports by Exception (partition-specific) 0 = disable 1 = enable	If enabled, Open/Close reports are sent only if the openings/closings occur outside the arm and disarm windows. NOTES: Open reports are also suppressed during the closing window in order to prevent false alarms if the user arms the system, then re-enters the premises, for example to retrieve a forgotten item. Openings and closings are still recorded in the event log. This field must be set to 1 if No Opening and No Closing reports are to be sent.
2*10	Allow Disarming Only During Arm/Disarm Windows (partition-specific) 0 = disable 1 = enable	If enabled, disarming of the system is allowed only during the arming/disarming windows, or if the system is in alarm (if 2*11 is set to 1). NOTE: This applies only to Operator-level users. Installer, Master, and Manager-level users can disarm the system at any time.
2*11	Allow Disarm Outside Window if Alarm Occurs 0 = disable 1 = enable	If enabled, allows the system to be disarmed outside the programmed disarm (opening) window if an alarm has occurred. Otherwise disarming is allowed only during the disarm window. NOTE: Used only if field 2*10 is enabled.
2*18	Enable GOTO for this Partition (partition-specific) 0 = disable 1 = enable	If enabled, this partition can be accessed from another partition's keypad using the GOTO command. NOTE: Must be disabled "0" for partition 1 in Commercial Fire installations.
2*19	Use Partition Descriptor 0 = disable 1 = enable	If enabled, the normal keypad display will include a partition number and four-digit descriptor.
2*20	Enable J2 Triggers for Partition (partition-specific) 0 = disable 1 = enable	If enabled, the J2 triggers function for this partition.

FIELD	TITLE and DATA ENTRIES	EXPLANATION
2*21	Supervision Pulses for Communicators 0 = disable 1 = enable	Silent Panic/Duress, Supervisory, and Trouble. If enabled, causes the control to send periodic short pulses on the J2 communicator triggers to the communications device. The communications device uses these pulses to determine that its connection to the control is still intact. Must be set to "00000" for Commercial Fire and Burglary installations. Not Used.
2*22	Display Fire Alarms of Other Partitions (partition-specific) 0 = disable 1 = enable	If enabled, allows fire alarms that occur on other partitions to be displayed at this partition's keypad(s). NOTE: Must be disabled "0" for partition 1 in Commercial Fire installations.
2*23	Display Burg, Panic and CO Alarms for Other Partitions (partition-specific) 0 = disable 1 = enable	If enabled, allows burglary, panic and CO alarms that occur on other partitions to be displayed at this partition's keypad(s). NOTE: Must be disabled "0" for partition 1 in Commercial Fire installations.
2*24	Display Troubles of Other Partitions (partition-specific) 0 = disable 1 = enable	If enabled, allows troubles that occur on other partitions to be displayed at this partition's keypad(s). NOTE: Must be disabled "0" for partition 1 in Commercial Fire installations.
3*00	Check or TRBL Display 0 = CHECK 1 = TRBL	Select whether the system should display CHECK or TRBL when a trouble condition occurs.
3*01	Event Display Lock 0 = disable 1 = enable	If enabled, the system locks the display on the first fire alarm. Press * to display the next fire alarm in the system. If disabled, the system scrolls all alarms automatically. When 3*01 is Enabled, the following priorities go into effect: The First event to occur is locked on the display; subsequent events will be displayed in priority order: Priority 1: Life Safety: ZT 06, 07, 09, 16, 17, and Duress override all other s below Priority 2: Property Safety: ZT 01, 02, 03, 04, 05, 10 override all other s below Priority 3: Supervisory: ZT 14, 18, 19 and Fire Trouble override all other s below Priority 4: System: AC Loss, Low Bat, Line Cut, etc. do not override any other events NOTE: Must be set to "1" for Commercial Fire Installations.
3*12	Zone Type 18 Delay Use 0 = disable 1 = enable	If enabled, use the delay time programmed in field 3*16.
3*13	Fire Supervisory Response to Open/Short (Applies to Zone Type 18) 0 = disable 1 = enable	If "0" is selected, the system will respond with a trouble on open, and a supervisory on short. If "1" is selected, the system will respond with a supervisory on open, and a supervisory on short. Must be set to "0" for Commercial Fire and Commercial Burglary installations.

FIELD	TITLE and DATA ENTRIES	EXPLANATION																																								
3*14	Waterflow Alarm Silence Option 0 = silenced by User Code + OFF 1 = silenced when zone restores	Select how the Waterflow zone type will be silenced. NOTES: This feature may be set to 1 only by permission of the local authority. For an output of a 4204CF to be silenced when 3*14=1, all Type 17 (Waterflow) zones activating the output must be put into a Zone List, and that Zone List must be the STP condition of the 4204CF fire output. In addition to the STP ZL, you also need an STP ZT of 22 in order to silence via code + off in the event the zone does not restore. Since a Type 17 zone is processed as a FIRE alarm, it will activate outputs programmed for STT ZT 17, 16, 09, and 39. The only way to have individual output activations (e.g. ZT17 versus ZT09) is to use zone lists. NOTE: Must be set to "0" for Commercial Fire installations.																																								
3*16	Zone Types 17 & 18 Delay Enter 01-15 times 2 seconds Enter 00 for no delay	Select the delay time for zone types 17 and 18. The zone must be faulted for entire delay time before an alarm or supervisory condition occurs. This may prevent alarms due to minor fluctuations in waterflow. Maximum combined delay of 3*16 and 3*18 cannot exceed 90 seconds for UL installations. NOTE: Must be set to "00" for Commercial Fire installations.																																								
3*17	Zone 6 Alternate Function Enable 0 = disable 1 = enable	If enabled, zone 6 may be used as a tamper zone (bell and cabinet tampers). If used, the zone will annunciate in accordance with response type, rather than a ground fault when a ground fault is detected.																																								
3*18	Extended Delay for Zone Types 17 & 18 0 = no extended delay 1 = multiply delay by 4	This option allows the delay programmed in field 3*16 for Waterflow and Supervisory zones to be extended by four times. NOTE: Must be set to "0" for Commercial Fire installations.																																								
3*19	Auxiliary Input Alternate Function Enable 0 = disable 1 = enable	If enabled, pins 5 and 9 on the J2 connector function as Printer RXD and DTR, respectively. If disabled, they function as fire alarm trigger and Communications Device Xmit Okay. See the chart at field 3*20 for the J2 trigger configurations. NOTE: If field 3*19 is enabled, you cannot use a Communications Device connected to the J2 trigger.																																								
3*20	Trigger Outputs Function Selection 0 = remote keypad sounder 1 = keyswitch LEDs	Select the function of the J2 trigger outputs. See chart below.																																								
		<table border="1"> <thead> <tr> <th>J2 Pin</th> <th>Field 3*19 = 0 Field3*20 = 0</th> <th>Field 3*19 = 0 Field3*20 = 1</th> <th>Field 3*19 = 1</th> </tr> </thead> <tbody> <tr> <td>1</td> <td>Panic Alarm</td> <td>Panic Alarm</td> <td>As selected in field 3*20</td> </tr> <tr> <td>2</td> <td>Trouble</td> <td>Trouble</td> <td>As selected in field 3*20</td> </tr> <tr> <td>3</td> <td>Burglary Alarm</td> <td>Burglary Alarm</td> <td>As selected in field 3*20</td> </tr> <tr> <td>4</td> <td>Fire Supervisory</td> <td>Fire Supervisory</td> <td>As selected in field 3*20</td> </tr> <tr> <td>5</td> <td>Fire Alarm</td> <td>Fire Alarm</td> <td>Printer RXD</td> </tr> <tr> <td>6</td> <td>Remote Console Sounder</td> <td>Keyswitch Ready LED</td> <td>As selected in field 3*20</td> </tr> <tr> <td>7</td> <td>Open/Close</td> <td>Keyswitch Armed LED</td> <td>As selected in field 3*20</td> </tr> <tr> <td>8</td> <td>Ground</td> <td>Ground</td> <td>Ground</td> </tr> <tr> <td>9</td> <td>Communicator Xmit Okay</td> <td>Communicator Xmit Okay</td> <td>Printer DTR</td> </tr> </tbody> </table>	J2 Pin	Field 3*19 = 0 Field3*20 = 0	Field 3*19 = 0 Field3*20 = 1	Field 3*19 = 1	1	Panic Alarm	Panic Alarm	As selected in field 3*20	2	Trouble	Trouble	As selected in field 3*20	3	Burglary Alarm	Burglary Alarm	As selected in field 3*20	4	Fire Supervisory	Fire Supervisory	As selected in field 3*20	5	Fire Alarm	Fire Alarm	Printer RXD	6	Remote Console Sounder	Keyswitch Ready LED	As selected in field 3*20	7	Open/Close	Keyswitch Armed LED	As selected in field 3*20	8	Ground	Ground	Ground	9	Communicator Xmit Okay	Communicator Xmit Okay	Printer DTR
J2 Pin	Field 3*19 = 0 Field3*20 = 0	Field 3*19 = 0 Field3*20 = 1	Field 3*19 = 1																																							
1	Panic Alarm	Panic Alarm	As selected in field 3*20																																							
2	Trouble	Trouble	As selected in field 3*20																																							
3	Burglary Alarm	Burglary Alarm	As selected in field 3*20																																							
4	Fire Supervisory	Fire Supervisory	As selected in field 3*20																																							
5	Fire Alarm	Fire Alarm	Printer RXD																																							
6	Remote Console Sounder	Keyswitch Ready LED	As selected in field 3*20																																							
7	Open/Close	Keyswitch Armed LED	As selected in field 3*20																																							
8	Ground	Ground	Ground																																							
9	Communicator Xmit Okay	Communicator Xmit Okay	Printer DTR																																							
3*21	Maximum Number of Dialer Attempts Enter the number of dialing attempts 1-8.	Select the maximum number of dialer attempts for the system. NOTE: Must be 3, 4, or 5 for NFPA 72 compliant systems if a secondary phone number is programmed.																																								
3*30	Dialer Selection 0 = disable 1 = enable	This field has two entries, one for each dialer (main and backup). Enter 1 if the dialer is being used. NOTE: If 3*30 is disabled (0, 0), the panel does not report at all via a Communications Device.																																								

FIELD	TITLE and DATA ENTRIES	EXPLANATION
3*31	Backup Dialer TouchTone or Rotary 0 = rotary 1 = touchtone	Select the dialing method for the backup dialer.
3*50	Zone Type Restore Enables for Types 16-18 0 = disable 1 = enable	This field has three entries, one for each zone type. Select the zone types that will send Restore reports. Must be 1 for UL commercial fire and burglary installations
3*55	Second OFF for Bell 1 0 = disable 1 = enable	If enabled, the system silences bell 1 output when the second User Code + OFF Code is entered after a fire alarm. If disabled, the system silences bell 1 output after the first User Code + OFF .
3*56	Second OFF for Bell 2 0 = disable 1 = enable	If enabled, the system silences bell 2 output when the second User Code + OFF Code is entered after a fire alarm. If disabled, the system silences bell 2 output after the first User Code + OFF .
3*57	Confirmation of Arming Ding Bell 2 & Auxiliary Relay 0 = disable 1 = enable	This field has two entries, one for bell 2 and one for the auxiliary relay. If enabled, produces ½-second external alarm sounding (“ding”) at the end of exit delay (or after kissoff from the central station, if sending closing reports). NOTE: If using a keyfob, when the button is pressed, either for arming or disarming, the bell will ding indicating that the button is working. Must be 1 for Commercial Burglary installations.
3*59	Enable Bell 2 & Auxiliary Relay Chime Annunciation 0 = disable 1 = enable	This field has two entries, one for bell 2 and one for the auxiliary relay. If enabled, the system produces chime annunciation on the output. NOTE: Must be set to “0” if Bell 2 or Aux. Relay is used for Fire.
3*60	Bell 2 & Auxiliary Relay Timeout Enter 01-15 multiplied by 2 minutes. 00 = no timeout.	This field has two entries, one for bell 2 and one for the auxiliary relay. Defines the length of time the output and the keypad’s sounder will sound for all audible alarms. Must be a minimum of 16 minutes for Commercial bBrglary installations and a minimum 6 minutes for Commercial Fire installations.
3*61	Auxiliary Relay Function Selection 0 = trouble/supervisory 1 = alarm, silenced by User Code + OFF 2 = smoke detector reset 3 = battery save 4 = alarm, silenced by User Code + # + 67	Select the condition that will trigger the auxiliary relay. NOTES: Select “4” for applications requiring independent resetting of the relay. Smoke detector reset triggers the relay momentarily (approximately 6 seconds) on the second User Code + OFF entry. Battery save is used to disconnect power from non-critical loads 4 hours after AC loss.
3*82	Burglary Features on Partition 1 Enable 0 = disable 1 = enable	If enabled, arming, test and chime modes can be used on partition 1. NOTES: These features are automatically enabled on all other partitions. Must be set to “0” in Commercial Fire installations.
3*85	System Zone Bypass Inhibit 0 = prevent bypass 1 = allow only installer to bypass 2 = allow only installer and master codes to bypass	Select which codes, if any, that can bypass fire zones and systems zones. NOTES: This applies to fire zones programmed with zone types 9, 16, 17, and 18 and system zones 970-977. The bypassing can only be done from partition 1.

Scheduling Options

UL

- You must program Bypass and Auto-Arm Fail reports for UL installations.
- Auto-disarming is not permitted in UL installations.
- You must not program Random Scheduling of Time Driven Events for UL installations.

General

The scheduling features allow certain operations to be automated, such as arming, disarming, bypassing of zones, and activating relay outputs.

The system uses time windows (a programmed period of time with a start and stop time) for defining open/close schedules, holiday schedules, user-defined temporary schedules, and access schedules for users.

Scheduled events are programmed by user-friendly menu modes of programming (#80, #81, #83, and #93 modes), explained in detail in this section. These menus take you step by step through the options.

Auto Arming

The system can automatically arm (AWAY Mode) a partition at the end of a pre-determined closing (arming) time window.

Auto Arming can be delayed three ways: by use of the Auto-Arm Delay, the Auto-Arm Warning, or by manually extending the closing (arming) time window with a keypad command.

The system can also automatically bypass any open zones when auto arming.

Auto-Arm Delay

Auto-Arm Delay provides a delay (grace period) before auto arming. It starts at the end of the closing time window.

The delay is set in 4-minute increments, up to 56 minutes in partition-specific program field 2*05. At the expiration of this delay, the Auto-Arm Warning will start.

Auto-Arm Warning

The Auto-Arm Warning causes the keypad sounder to warn the user of an impending Auto-Arm.

The warning can be set from 1 to 15 minutes prior to the arming in partition-specific program field 2*06. During this period the keypad beeps every 15 seconds and displays "AUTO ARM ALERT." During the last 60 seconds, the keypads beep every 5 seconds.

The panel arms at the conclusion of the Auto-Arm Warning period.

Force Arm

The Force Arm option causes the panel to attempt to bypass any faulted zones prior to auto arming (panel performs a force-arm). This option is set in partition-specific program field 2*08.

Extend Closing Window

A user can manually delay the arm (closing) time window by 1 or 2 hours. This is done by entering a keypad command, (User Code + #82), which prompts the user to enter the desired extension time of 1 or 2.

This feature is useful if a user must stay on the premises later than usual.

The Auto-Arm delay and warning periods begin at the end of the extension.

Auto Disarming

The system can automatically disarm a partition at the end of a pre-determined opening (disarm) time window.

The disarming time can be delayed by using the Auto-Disarm Delay feature.

Disarm Delay

Auto-Disarm Delay provides a delay before auto disarming. This delay is added to the end of the disarm time window.

The delay is set in 4-minute increments, up to 56 minutes, in partition-specific program field 2*07.

Restrict Disarming

This option allows disarming by users only during the disarm time window and during the arming time window (in case user needs to re-enter premises after manually arming the partition).

This option is set in partition-specific field 2*10. If field 2*10 is set, we highly recommend setting field 2*11, as well. This field allows the partition to be disarmed outside the arm/disarm time windows only if the partition is in alarm.

Exception Reports

This option allows the reporting of openings and closings to the central station only if the arming and disarming occurs outside of the predetermined opening and closing time windows. It is set in partition-specific field 2*09.

The system can be programmed to send Failed to Open and Failed to Close reports if the partition is not armed or disarmed by the end of the corresponding time window.

Limitation of Access of Users by Time

A user’s access to the system can be limited to a certain time period. Outside this time, that user’s code is inactive. The system provides up to eight access schedules, each consisting of two time windows (typically one for opening, one for closing) for each day of the week and two time windows for holidays.

The access schedules are programmed in the #80 Menu Mode, and enabled when a user’s access code is added to the system.

If a user tries to operate the system outside the schedule, the alpha keypad displays “Access Denied.”

Time-Driven Events

The system can automatically activate and de-activate relays at predetermined times to turn lights or other devices on and off.

The Time-Driven events can be activated at different times in relation to a time window:

- At the beginning of a time window
- At the end of a time window
- During a time window (on at beginning of window, off at end)
- At both the beginning and end of the time window (e.g., to sound a buzzer at the beginning and end of a coffee break)

The system can perform the same actions on a daily basis, or can perform an action only once (e.g., turn on the porch light this Wednesday at 8:00 PM).

The system also provides up to 20 programmable “timers” available to the end user for the purpose of activating output devices at preset times and days.

Time Window Definitions

Scheduled events are based on time windows, (periods of time) during which an event may take place. The system supports up to 20 time windows, each defined by a “Start” time and a “Stop” time.

The windows are shared by both partitions, and are used when programming the various schedules (open/close, limitation of access), as well as for Time-Driven event control.

Scheduling Example

A store that has the following hours:

Monday to Friday	9am to 6pm
Saturday	10am to 4pm
Sunday	Closed
Holidays	Closed

The owner desires the following time windows to allow time for employees to arm or disarm the system:

Monday to Friday	Open (disarm)	8am to 9am
	Close (arm)	6pm to 6:30pm
Saturday	Open (disarm)	9am to 10am
	Close (arm)	4pm to 4:30pm
Sunday & Holidays	Closed	

For this schedule, the four time windows need to be programmed:

Window	Start	Stop	Purpose
1	8am	9am	Monday-Friday open window
2	9am	10am	Saturday open window
3	4pm	4:30pm	Saturday close window
4	6pm	6:30pm	Monday-Fri. close window

Using the #80 *Menu Mode*, the installer can program open/close schedules by assigning a time window to a day of the week (windows are entered as 2-digit entries)

Mon	Tue	Wed	Thu	Fri	Sat	Sun	Hol
Op/Cl	Op/Cl	Op/Cl	Op/Cl	Op/Cl	Op/Cl	Op/Cl	Op/Cl
01/04	01/04	01/04	01/04	01/05	02/03	00/00	00/00

NOTE: 00 is entered for those days on which the store is closed.

Employees can arm and disarm the system, when programmed, within the open and close time windows without causing a report to be sent to the central station (reporting by exception, field 2*09). The system can be programmed to automatically arm/disarm in case an employee fails to arm/disarm manually (auto-arm/auto-disarm).

Open/Close Schedules Definitions

General

The open/close scheduling is controlled by one of three schedules. Each schedule consists of one time window for openings and one time window for closings.

There are three types of schedules available: Daily, Holiday, and Temporary.

Daily Schedule

Each partition can have one daily schedule consisting of one opening window and one closing window per day.

Holiday Schedule

A holiday schedule overrides the regular daily schedule on selected holidays throughout the year.

The opening and closing windows are programmed in the daily schedule, but the holidays themselves are defined in *Holiday Schedule Programming* in the #80 *Menu Mode*.

Temporary Schedule

The temporary schedule provides a method for the end user to override the daily and holiday schedules. It consists of one opening window and one closing window for each day of the week. The schedule takes effect for up to one week, after which it is automatically deactivated.

This schedule is programmed using the #81 Temporary Schedule Menu Mode.

Additional Schedules

Additional opening and closing schedules can be programmed using the *Time-Driven Event Programming*. For example, a schedule for normal store openings/closings can be programmed with a daily open/close schedule, and another open/close schedule for a lunch hour can be programmed using the Time-Driven event schedule programming.

Refer to “Time-Driven Events” later in this section for detailed information.

Open/Close Reports by Exception

The system can help reduce communication traffic to the central station by using the Open/Close Reports by Exception feature. The Open/Close by Exception option suppresses these reports from being sent to the central station if an arm or disarm is done *within* the expected time window. Reports are only sent if the arm or disarm occurs outside the assigned time window.

The system keeps a record of *all* openings/closings in its event log.

If a disarming occurs during a closing window (for example, a person who arms the system forgets something and has to re-enter), the Opening report (although outside of the opening window) will not be sent (as long as that disarming occurs within the closing window).

This option is programmed in partition-specific program field 2*09.

Example of Open/Close Exception Reporting & Scheduling

The following chart gives an example of how the Open/Close by Exception reporting works.

6:01PM	5:59AM	6AM	9AM	9:01AM	3:59PM	4PM	6PM	6:01PM	5:59AM
Early Opening reports are sent if system is manually disarmed before opening window begins. Early and Late Opening and Closing reports are programmable options in Report Code Programming in the Programming Guide. They are not dependent on the programming of the Exception Reporting option.		Opening Window No reports are sent if system is disarmed during this time window. If an arming occurs, a Closing report is sent to the central station regardless of how the Exception Reporting option is set.		Auto-disarm delay begins. Auto-disarm occurs after delay (if auto-disarm is enabled). Missed Opening reports are sent if manual disarming has not occurred at expiration of opening window. Late Opening reports are sent if disarm occurs after the opening window expires. Early Closing reports are sent if manual arming occurs before the closing window begins. Missed Opening/Closing type reports are programmed in Report Code Programming in the Programming Guide. The Exception Reporting option must be set for these to be sent.		Closing Window No reports are sent if system is armed* during this time window. * or disarmed if user needs to re-enter premises.		Auto-arm delay begins. Auto-arm warning begins. Auto-arm occurs after warning expires (if auto-arm is enabled). Missed Closing reports are sent if manual arming has not occurred at expiration of closing window. Late Closing reports are sent if system is manually armed after the closing window expires.	

Scheduling Menu Mode

The #80 Scheduling Menu Mode is used to program most of the scheduling and timed-event options. Enter **User Code + [#] + [8] + [0]** from the normal operating mode. **NOTE:** Only users with an Installer or Master level user code may enter the #80 mode.

The following can be programmed while in this mode:

- time windows
- open/close schedules to each partition
- holiday schedules
- Time-Driven events (for system functions and relay activation)
- limitation of access schedules

Some scheduling features are programmed in Data Field Programming Mode (**Installer Code + 8 0 0**). Some features are programmed in the #93 Menu Mode.

The programming scheduling fields are listed below.

System-Wide Fields:	
*04	Enable Random Timers
1*74 –1*75	Relay timeout values
2*01-2*02	Daylight saving time options
2*11	Allow disarming outside window if alarm occurs
Partition-Specific fields:	
1*76	Control relay for this partition
2*05	Auto-arm delay value
2*06	Auto-arm warning time
2*07	Auto-disarm delay value
2*08	Force-arm enable
2*09	Open/Close Reporting by Exception
2*10	Restrict disarm only during windows
#93 Menu Mode (System Group #3)	
Scheduling related report codes	

Event-driven options are programmed using *Output Programming* in #93 Menu Mode. Relay activation can also be Time-Driven and that those are programmed using the #80 Menu Mode. Refer to the *Time-Driven Event Programming* later in this section for the procedure.

Steps to Program Scheduling Options



This section contains examples of the worksheets only. For complete worksheets, see the *Programming Guide* accompanying this Installation and Setup Guide.

In order to use #80 Scheduling Menu Mode, use the worksheets to do the following:

1. Define time windows (up to 20)
2. Define the daily open/close schedules (one schedule per day, per partition)
3. Define the holidays to be used by the system (up to 16)
4. Define limitation of access times (up to eight schedules)
5. Define the Time-Driven events (up to 20)

NOTE: Temporary schedules are programmed using #81 Menu Mode.

Use #80 Scheduling Menu Mode to perform the following functions:

6. Program the time windows
7. Program the open/close schedules
8. Program the Time-Driven events
9. Program the access schedules

Scheduling Menu Structure

To program schedules, enter Scheduling Program Mode:

User Code + [#] + [80]. (Installer or Master level user code.)



Scheduling Program Mode can be entered only when all partitions are disarmed.

There are six procedures of scheduling menus accessed via #80, as shown below. Entering **1** at a displayed main menu prompt selects that menu procedure. Prompts for programming that scheduling feature then appear. Enter **0** to skip a procedure and display the next menu option.

PROMPT	EXPLANATION
Time Window ? 1 = YES 0 = NO 0	Upon entering Schedule Menu Mode, this prompt appears. Enter 1 to program time windows. Refer to <i>Time Windows Programming</i> later in this section for detailed procedures. Enter 0 to move to the "O/C Schedules?" prompt.
O/C Schedules ? 1 = YES 0 = NO 0	Enter 1 to program opening and closing schedules. Refer to <i>Open/Close Schedules Programming</i> later in this section for detailed procedures. Enter 0 to move to the "Holidays?" prompt.
Holidays ? 1 = YES 0 = NO 0	Enter 1 to program holiday schedules. Refer to <i>Holiday Schedule Programming</i> later in this section for detailed procedures. Enter 0 to move to the "Timed Events?" prompt.
Timed Events ? 1 = YES 0 = NO 0	Enter 1 to program timed events for relay outputs, additional schedules, and other system functions. Refer to <i>Time-Driven Event Programming</i> later in this section for detailed procedures. Enter 0 to move to the "Access Sched?" prompt.
Access Sched. ? 1 = YES 0 = NO 0	Enter 1 to program access schedules. Refer to <i>Limitation of Access Schedules Programming</i> later in this section for detailed procedures. Enter 0 to move to the "Quit?" prompt.
Quit ? 1 = YES 0 = NO 0	Enter 1 to quit #80 Scheduling Menu Mode and return to normal operating mode. Enter 0 to make any changes or review the scheduling programming options. If you press 0 , the "Time Window?" prompt is displayed.

Time Windows

The system provides 20 time windows that are defined with start and stop times. These windows are used for various open/close and access schedules, as well as for output controls, and are the basis of the scheduling system. These windows are shared between both partitions.

Time Windows Worksheet

The following worksheet is an example of the worksheet found in the *Programming Guide*. This worksheet will help you define time windows and scheduling aspects of this system before you program them. Note that time windows **can** span midnight; for example, from 11 PM to 1 AM.

Time Window Number	Start Time (HH:MM)	Stop Time (HH:MM)
1		
2		
3.....20		

A time window must have a start and a stop time.

Time Windows Programming

Enter Scheduling Mode by entering **Installer Code + [#] + [80]**. The keypad displays the *Time Window Programming* prompt.

PROMPT	EXPLANATION
Time Window ? 1 = YES 0 = NO 0	Enter 1 at this main menu prompt to program time windows.
Time Window # ? 01-20, 00 = Quit 01	Enter the 2-digit time window number (01-20) to be programmed. Press [*] to accept the entry. Enter 00 + [*] at the "Time Window #?" prompt to quit time window programming and display the "Quit ?" prompt.
01 TIME WINDOW 00:00AM 00:00AM	If you entered a time window number, the cursor is now positioned on the tens of hours digit of the start of window entry. Enter the desired start of window hour and press [*]. The cursor moves to the minutes position. Enter the desired minutes and press [*]. Toggle the AM/PM indication by pressing any key 0-9 while the cursor is under the A/P position and then press [*]. Repeat this to program the stop of window entry. When the entry is completed, the "Time Window #?" prompt is displayed again. Enter the next time window number to be programmed and repeat the procedure.
Quit ? 1 = YES 0 = NO 0	Enter 0 at the Quit ? prompt to return to the main menu choices and continue programming. Enter 1 to quit Scheduling Menu Mode.



Because the time windows are shared between both partitions, it is important to make sure that changing a time window does not adversely affect desired actions in the other partition.

Daily Open/Close Schedules

Each partition can be assigned one daily open/close schedule, plus a holiday schedule. Temporary schedules are programmed separately, using the *#81 Temporary Schedule Menu Mode*. To program additional open/close schedules, see *Time-Driven Events Programming* later in this section for the procedure.

Open/Close Schedule Worksheet

The following worksheet is an example of the worksheet found in the *Programming Guide*. Write the previously defined time window numbers for open and close for each partition.

Part	Mon		Tues		Wed		Thur		Fri		Sat		Sun		Hol	
	Op	Cl	Op	Cl	Op	Cl	Op	Cl	Op	Cl	Op	Cl	Op	Cl	Op	Cl
1																
2																

Open/Close Schedule Programming

After entering Scheduling Menu Mode, press [0] until the “O/C Schedules?” prompt appears.

PROMPT	EXPLANATION
O/C Schedules ? 1 = YES 0 = NO 0	Enter 1 to program opening and closing schedules.
Partition # ? 01-02, 00 = Quit 01	Enter the appropriate partition number for which the following open/close schedules will apply. Enter 00 + [*] at the “Partition #?” prompt to quit open/close schedules programming and display the “Quit ?” prompt.
Mon P1 OP WIND.? 00:00 00:00 00	Enter the time window number 01-20 for the displayed day’s opening schedule beginning with Monday. Enter 00 if no schedule is desired for a particular day. As the number is keyed in, the actual time that has been stored for that window number is displayed as a programming aid. Press [*] to accept the entry.
Mon P1 CL WIND.? 00:00 00:00 00	Enter the time window number for the displayed day’s closing schedule. As the number is keyed in, the actual time that has been stored for the window number is displayed. Press the [*] key to accept the entry.
Tue P1 OP WIND.? 00:00 00:00 00	The keypad now prompts for Tuesday’s open/close schedule. Follow the procedure for Monday’s prompts. When the last day of the week has been programmed, the holiday opening and closing window prompts are displayed.
Hol P1 OP WIND.? 00:00 00:00 00	Repeat the procedure for the holiday opening and closing time windows. Press the [*] key to accept the entry. When the entries are completed, the “Partition #?” prompt is displayed again. Repeat this procedure for each partition in the system.
Quit ? 1 = YES 0 = NO 0	Enter 0 at the “Quit ?” prompt to return to the main menu choices and continue programming. Enter 1 to quit Scheduling Menu Mode.

Holiday Schedules

A holiday schedule overrides the regular daily open/close schedule on the programmed holidays throughout the year.

The system provides up to 16 holidays that can be assigned for the system. Each holiday can be assigned to any combination of partitions. List the desired holidays in a Month/Day format on the worksheet. Check the partitions for which these holidays apply.

Holiday Schedule Worksheet

The following worksheet is an example of the worksheet found in the *Programming Guide*.

Holiday	Month/Day	Partition	
		1	2
	/		
1	/		
2	/		

Holiday Schedule Programming

After entering Scheduling Menu Mode, press [0] until the “Holidays ?” prompt appears.

PROMPT	EXPLANATION
Holidays ? 1 = YES 0 = NO 0	Enter 1 to program holiday schedules.
HOLIDAY NUMBER ? 01-16,00=Quit 01	Enter the 2-digit holiday number (01-16) to be programmed and press [*] to accept entry. Enter 00 + [*] at the “Holiday Number?” prompt to quit the holiday menus and display the “Quit ?” prompt.
01 ENTER DATE 00/00	The cursor is now positioned on the tens of months digit. Enter the appropriate month, then press [*] to proceed to the day field. Enter the appropriate day for the holiday. Press [*] to accept the entry.
Part ? 1 2 Hit 0-2 x x	Holidays can be set for any partition, as follows. Press [0] to turn all partitions on or off, or use keys 1-2 to toggle the letter “x” under the partition to which this holiday will apply. Press the [*] key when all desired partitions have been assigned. The “Holiday Number?” prompt is displayed again. Repeat the procedure for each holiday to be programmed.
Quit ? 1 = YES 0 = NO 0	Enter 0 at the “Quit ?” prompt to return to the main menu choices and continue programming. Enter 1 to quit Scheduling Menu Mode.

Time-Driven Events

These schedules are used to activate outputs, bypass zones, etc. based on time. There are 20 of these schedules that may be programmed for the system, each governed by the previously defined time windows.

The actions that can be programmed to automatically activate at set times are: relay commands, arm/disarm commands, zone bypassing commands, and open/close access conditions.

Time-Driven Events Worksheet

The following worksheet is an example of the worksheet found in the *Programming Guide*. Fill out the worksheet using the steps outlined below.

Sched Num.	Time Window	Days									Action Desired	Action Specifier	Activation Time
		M	T	W	T	F	S	S	H				
1													
2													
3...20													

1. **Enter the schedule number (01-20) and time window number (01-20)**, and note the day of the week the action is desired.
2. **Enter the code for the desired action and action specifier.** The action codes represent the events that are to take place when the scheduled time is reached. Each action also requires an action specifier, which defines what the action will affect (relay, relay group, partition, zone list, user group). The action specifier varies, depending on the type of action selected.

The following is a list of the Action Codes (desired actions) used when programming Time-Driven events. Note that these codes are independent of the relay codes programmed during *Output Programming* in the #93 Menu Mode.

Relay Commands

Action Code	Action	Action Specifier
01	Relay On	Relay #
02	Relay Off	Relay #
03	Relay Close for 2 seconds	Relay #
04	Relay Close XX minutes (set in field 1*74)	Relay #
05	Relay Close YY seconds (set in field 1*75)	Relay #
06	Relay Group On	Relay Group #
07	Relay Group Off	Relay Group #
08	Relay Group Close for 2 seconds	Relay Group #
09	Relay Group Close XX minutes (set in field 1*74)	Relay Group #
10	Relay Group Close YY seconds (set in field 1*75)	Relay Group #

Arm/Disarm Commands

Action Code	Action	Action Specifier
20	Arm-STAY	Partition(s)
21	Arm AWAY	Partition(s)
22	Disarm	Partition(s)
23	Force Arm STAY (Auto-bypass faulted zns)	Partition(s)
24	Force Arm AWAY (Auto-bypass faulted zns)	Partition(s)



- The auto-arm warning (field 2*06) applies when using Time-Driven events to auto-arm.
- Temporary schedules do not override an auto-arming or auto-disarming programmed in Time-Driven events.
- The auto-arming window cannot be extended using the Installer Code + #82 Mode.

Bypass Commands

Action Code	Action	Action Specifier
30	Auto bypass – Zone list	Zone list #
31	Auto unbypass – Zone list	Zone list #

Open/Close Windows

Action Code	Action	Action Specifier
40	Enable Opening Window by partition	Partition(s)
41	Enable Closing Window by partition	Partition(s)
42	Enable Access Window for access group	Access Group
50	Off-Normal Reminder (starts local keypad beeping if fire or system trouble condition exists)	None

Access Control Commands 55 – 78 Not Used

3. **Enter the desired activation time** (when the action is to take place). Select from:

Activation Time	Description
1	Beginning of time window.
2	End of time window.
3	During time window active period only (on at beginning of window, off at end). For example, if bypass is selected to activate during the window, zones in a zone list are bypassed at the beginning of the window and unbypassed at the end of the window.
4	Beginning and end of time window (e.g., a coffee break buzzer). In this example, if relay pulse is selected, the relay pulses for 2 seconds at the beginning of the window, signaling the beginning of the coffee break. At the end of the window it pulses again, signaling the end of coffee break.

Time-Driven Event Programming

The following menu items must first be programmed in *Output Programming in the #93 Menu Mode*:

Enter Relay No.	(reference identification number)
Output Group	(if applicable)
Restriction	
Output Type	(V-Plex, 4204/4204CF)
Zone No.	(V-Plex)
ECP Address	(4204/4204CF)
Relay No.	(4204/4204CF)

After entering Scheduling Menu Mode, press [0] until the “Timed Events ?” prompt appears.

PROMPT	EXPLANATION
--------	-------------

Timed Events ? 1 = YES 0 = NO 0

Enter 1 to program timed events.

TIMED EVENT # ? 01-20, 00=Quit 01

Enter the timed event number to be programmed (01-20).

Press [*].

The system then prompts the user to enter the desired action to be taken.

Enter 00 at the “TIMED EVENT #?” prompt to quit the timed event menus and display the “Quit ?” prompt.

01 ACTION ? none 00

Enter the action code for this timed-event number from the list at the left. This could be an output command, an arming command, or any other Time-Driven event.

Press [*] to accept the entry. The prompt for the action specifier appears.

ACTION CODES	EXPLANATION	ACTION SPECIFIER
--------------	-------------	------------------

01=Relay On 02=Relay Off 03=Relay Close for 2 seconds 04=Relay Close XX minutes 05=Relay Close YY seconds

Actions 01-05

If you selected actions 01-05, the prompt at the right appears. Enter the relay number.

Press [*] to accept entry. The “Time Window ?” prompt appears.

01 RELAY # ? 00

06=Relay Group On 07=Relay Group Off 08=Relay Group Close for 2 seconds 09=Relay Group Close XX minutes 10=Relay Group Close YY seconds

Actions 06-10

If you selected actions 06-10, the prompt at the right appears. Enter the relay group number.

Press [*] to accept entry. The “Time Window ?” prompt appears.

01 RELAY GRP # ? 00

20=Arm-STAY 21=Arm AWAY 22=Disarm 23=Force Arm STAY 24=Force Arm AWAY 40=Enable Open Window by Part. 41=Enable Close Window by Part.
--

Actions 21-26 and 40-41

If you selected actions 21-24 or 40-41, the prompt at the right appears. Enter the partition to which the action applies. Enter 0 to select all partitions. Enter a partition number again to deselect it.

Press [*] to accept entry. The “Time Window ?” prompt appears.

PART? 1 2 HIT 0-2 X X

30=Auto bypass – Zone list 31=Auto unbypass – Zone list
--

Actions 30-31

If you selected actions 30-31, the prompt at the right appears. Enter the zone list number that contains the zones to be bypassed or unbypassed.

Press [*] to accept entry. The “Time Window ?” prompt appears.

01 ZONE LIST ? ENTER 01-15 01

42=Enable Access Window for Access group(s)

Action 42

If you selected action 42, the prompt at the right appears. Enter the group number to which the time window will apply.

Press [*] to accept entry. The “Time Window ?” prompt appears.

GROUP ? 12345678 HIT 0-8 X

ACTION CODES	EXPLANATION	ACTION SPECIFIER
50=Off-Normal Reminder	Action 50 No action specifier is required for this action since the condition that this occurs for are system-wide.	

PROMPT	EXPLANATION
--------	-------------

01 Time Window ? 00:00 00:00 01	Enter the time window number (01-20) for which this timed event is to occur. As the number is keyed in, the actual time that has been stored for the time window number is displayed. Press [*] to accept entry.
------------------------------------	---

01 Active time ? 0	Enter the activation time from 1-10 (listed below). As the number is keyed in, the activation time is displayed. The choices are: 1: Trigger at the start of the window. 2: Trigger at the end of the window. 3: Take effect only for the duration of the window. 4: Trigger at both the start and the end of the window. Example: coffee break buzzer. Press [*] to accept entry.
-----------------------	---

Days ? MTWTFSSH Hit 0-8 x x	The system then asks for which days the event is to be activated. Press 0 to toggle all days on or off; or press keys 1-8 to toggle the letter “x” under the day on or off (Monday = 1, Holiday = H = 8). When all entries have been made, the “TIMED EVENT #?” prompt is displayed again. Repeat the procedure for each timed event for the installation.
--------------------------------	---

Quit ? 1 = YES 0 = NO 0	Enter 0 at the “Quit ?” prompt to return to the main menu choices and continue programming. Enter 1 to quit Scheduling Menu Mode.
----------------------------	---

Limitation of Access Schedules

Limitation of Access is a means by which a user’s access code is limited to working during a certain period of time. The system provides eight Access Schedules, each of which consists of two time windows for each day of the week and two time windows for holidays (typically, one for an opening time window and the second for a closing time window). A user, required to follow a schedule, would be assigned to an access group of the same number (e.g., schedule 1= group 1). The user’s access code is assigned to a group when that user is added to the system. If no limitations apply, enter 0.

Limitation of Access Schedule Worksheet

Enter the appropriate time window numbers for each access schedule.

Acc Sch	Mon		Tues		Wed		Thurs		Fri		Sat		Sun		Hol	
	W1	W2	W1	W2	W1	W2	W1	W2	W1	W2	W1	W2	W1	W2	W1	W2
1																
2																
3...8																

NOTE: The holidays used for the access groups are the same as those defined in the holiday schedule.

Limitation of Access Schedules Programming

To program access schedules enter Scheduling Menu Mode **Installer Code + # 80**. After entering Scheduling Menu Mode, press [0] until the “Access Sched. ?” prompt appears.

PROMPT	EXPLANATION
--------	-------------

Access Sched. ? 1 = YES 0 = NO 0	Enter 1 to program access schedules.
-------------------------------------	--------------------------------------

ACCESS SCHED # ? 01-08, 00 = Quit 01	Enter the access control schedule number between 01 and 08. Press [*] to accept entry. Enter 00 at the “Access Sched #?” prompt to quit the access control menus and display the Quit ? prompt.
---	---

PROMPT	EXPLANATION
MON A1 Window 1 ? 00:00 00:00 00	Enter the first time-window number (01-20) for this access schedule for the displayed day. As the number is keyed in, the actual time that has been stored for the window is displayed. Press [*] to continue.
MON A1 Window 2 ? 00:00 00:00 00	Enter the second time-window number from 01-20 for this access schedule for the displayed day. As the number is keyed in, the actual time that has been stored for the window is displayed. Press [*] to continue.
TUE A1 Window 1 ? 00:00 00:00 00	Repeat the procedure for the other days of the week. When the last day of the week has been programmed, the windows for holidays may be entered.
Hol A1 Window 1 ? 00:00 00:00 00	Enter the first time-window number for holidays for this access schedule. As the number is keyed in, the actual time that has been stored for the window is displayed. Press [*] to continue.
Hol A1 Window 2 ? 00:00 00:00 00	Enter the second time-window number for holidays for this access schedule. As the number is keyed in, the actual time that has been stored for the window is displayed. Press [*] to continue.
Quit ? 1 = YES 0 = NO 0	Enter 0 at the "Quit ?" prompt to return to the main menu choices and continue programming. Enter 1 to quit Scheduling Menu Mode.

Temporary Schedules

Each partition can be assigned a temporary schedule, which overrides the regular open/close schedule (and the holiday schedule). This schedule takes effect as soon as it is programmed, and remains active for up to one week.

Only users with the authority level of manager or higher can program temporary schedules.

A temporary schedule affects only the partition from which it is entered. Temporary schedules can also be reused at later dates simply by scrolling (pressing [#]) to the "DAYS?" prompt and activating the appropriate days. This should be considered when defining daily time windows.

Temporary Schedule Worksheet

Partition/Windows	Mon	Tue	Wed	Thu	Fri	Sat	Sun
1 Disarm Window							
Start Time HH:MM							
Stop Time HH:MM							
Arm Window							
Start Time HH:MM							
Stop Time HH:MM							
2 Disarm Window							
Start Time HH:MM							
Stop Time HH:MM							
Arm Window							
Start Time HH:MM							
Stop Time HH:MM							

Temporary Schedules Programming

Enter **User Code + [#] + 81** to enter this mode.

PROMPT	EXPLANATION
Mon DISARM WIND. 00:00AM 00:00AM	<p>This prompt is for entering the start and end times of the disarm (opening) window for Monday.</p> <p>Upon entry of this mode, the cursor is positioned on the tens of hours digit of the start time of the disarm window. Enter the desired hour.</p> <p>Press [*] to move to the minutes field. The minutes are entered in the same manner. Press [*] to move to the AM/PM position. Pressing any key in the 0-9 range toggles the AM/PM indication.</p> <p>Repeat the procedure for the stop time entry.</p> <p>Press [*] to store the entries and move to the arming (closing) window for Monday. Pressing [#] scrolls you through the prompts without making any changes.</p>
Mon ARM WINDOW 00:00AM 00:00AM	<p>This prompt is for entering the start and end times of the arm (closing) window for Monday.</p> <p>The cursor is positioned on the tens of hours digit of the start time of the arm window. Enter the hour.</p> <p>Press [*] to move to the minutes field. The minutes are entered in the same manner. Press [*] to move to the AM/PM position. Pressing any key in the 0-9 range toggles the AM/PM indication.</p> <p>Repeat the procedure for the stop time entry.</p> <p>After the windows for that day have been completed, the system prompts for disarm and arm time windows for the next day. Press [#] if no changes are desired.</p>
Tue DISARM WIND. 00:00AM 00:00AM	<p>Repeat the procedure described above for all days of the week.</p> <p>When all the windows for all the days have been completed, the system prompts for which days of the schedule are to be activated.</p>
Days ? MTWTFSS Hit 0-7 x x	<p>This is the prompt that actually activates the temporary schedule.</p> <p>To select the days to be activated, enter 1-7 (Monday = 1). An "X" appears under that day, indicating the temporary schedule for that day is active. Entering a day's number again deactivates that day. Pressing 0 toggles all days on/off.</p> <p>The temporary schedule is in effect only for the days highlighted with the letter "x" under them. As the week progresses, the selected days are reset to the inactive state, but all other entries for the temporary schedule remain programmed.</p> <p>Press [*] to store the entries or press [#] to exit the Temporary Schedule Entry Mode without making any changes.</p>

User Scheduling Menu Mode

The system provides up to 20 "timers" available to the end user to control output devices. The output devices themselves are programmed into the system by the installer during *Output Programming* in the #93 *Menu Mode*. The end user needs only to know the output device number and its alpha descriptor.

The installer may set certain outputs to be "restricted" during *Output Programming* (this prevents the end user from controlling doors, pumps, Notification Appliance Circuits, etc.)

To enter this mode, the user enters **User Code + [#] + 83**.

PROMPT	EXPLANATION
Output Timer # ? 01-20, 00=Quit 01	<p>Enter the output timer number to be programmed (01-20). Press [*] to accept entry and move to the next prompt.</p> <p>Enter 00 to quit and return to normal operating mode.</p>
06 07:00P 11:45P PORCH LITE 04	<p>If that timer number has already been programmed, a summary screen appears. In this example:</p> <p>06 = Timer # 07:00PM = Start Time 11:45PM = Stop Time PORCH LITE = Descriptor for Output Device # 4 04 = Output Device # affected by this timer</p> <p>Press [*] to continue.</p>
06 ENTER OUTPUT# PORCH LITE 04	<p>Enter the desired output number (01-96). As the number is entered, the descriptor for that output device is displayed.</p> <p>Press [*] to continue.</p>



Entering **00** as the output number deletes the timer (Timer 06, in this example) and displays an output descriptor of “None.” Output devices are programmed via #93 Menu Mode.

PROMPT	EXPLANATION
<p>06 ON TIME ? 07:00 PM</p>	<p>The cursor is positioned on the tens of hours digit of the ON time. Enter the desired hour. Press [*] to move to the minutes field. The minutes are entered in the same manner. The AM/PM indication is toggled by hitting any key from 0-9 while the cursor is under the AM/PM position. Press [*] to continue.</p>
<p>06 OFF TIME ? 11:45 PM</p>	<p>The cursor positioned on the tens of hours digit of the OFF time. Enter the desired hour. Press [*] to move to the minutes field. The minutes are entered in the same manner. The AM/PM indication is toggled by hitting any key in the 0-9 range while the cursor is under the AM/PM position. Press [*] to continue.</p>
<p>06 DAYS? MTWTFSS HIT 0-7 x x</p>	<p>To select the days to be activated, enter 1-7 (Monday = 1). An “x” appears under that day, indicating the output for that day is active. Entering a day’s number again deactivates that day. Pressing 0 toggles all days on/off. The outputs are in effect only for the days highlighted with the letter “x” under them. As the week progresses, the selected days are reset to the inactive state, unless the permanent option is selected (next screen prompt). When completed, press [*] to continue.</p>
<p>06 Permanent ? 0 = NO,1 = YES 0</p>	<p>Selecting “Permanent” (1) means that this schedule will be in effect on a continuous basis. Selecting 0 means that this schedule will be in effect for one week only. The letter “x” under the day is then cleared, but all other entries for the output device remain programmed. Press [*] to accept entry. The system quits User Scheduling Mode and returns to normal operating mode.</p>

Downloading Primer

(Remote Downloading is not a UL Listed feature)

General Information

Downloading allows the operator to remotely access, program, and control the security system over normal telephone lines, IP, or GSM Communicators. Anything that can be done directly from the keypad can be done remotely, using ADEMCO's COMPASS downloading software. To communicate with the control panel, the following is required:

1. IBM PC-compatible 486 33MHz PC or better with 100 MB of available hard disk space and at least 8MB of RAM (12MB is preferred). Windows 3.X, Windows 95, 98, or Windows NT.

Phone Line Up Load/ Downloading

1. One of the following modems:
 - ADEMCO CIA
 - Hayes Smartmodem 1200 (external: level 1.2 or higher; internal: level 1.1 or higher)
 - Hayes Optima 24 + Fax 96 external
 - Hayes Optima 336
 - BizComp Intellimodem 1200 w/volume
 - BizComp Intellimodem 2400

Other brands are not compatible, even if claimed to be 100% compatible.



Internal modems must have a 4-position DIP switch. Modems with a 6-position DIP switch will not work.

2. Compass revision 1.5.8 or above.

IP/GSM Downloading

Revision 4.0 and above panels can be downloaded via the ECP bus over the following Communicators:

- 7845i-ent
- 7845-GSM (For Commercial Burglary use only)
- 7845i-GSM (For Commercial Burglary use only)

Access Security

The following four levels of protection guard the control against compromise while it is being accessed from a remote location:

1. Security code handshake: The subscriber's account number as well as an 8-digit ID number (known only to the office) must be matched between the control and computer.
2. Hang-up and callback: The control panel "hangs up" and calls the computer back at the pre-programmed number only if the security codes match.
3. Data encryption: All data that is exchanged between the computer and control is encrypted to reduce the possibility of anyone "tapping" the line and corrupting data.
4. Operator access levels: Operators may be assigned various levels of access to the downloader, each having its own log-on code. The access levels allow the operators read/write capabilities of the customers' account information. For a detailed explanation of the access levels, see the downloading software User Manual.

NOTES:

- Each time the control panel is accessed successfully, a Callback Requested report is sent to the central station, if Opening reports are programmed.
- When the system is downloading, the keypad displays "MODEM COMM."
- After each download or save an automatic time stamp is done, to indicate the last download (or save) and the operator ID number.
- A complete hard copy of each individual account can be obtained by connecting a printer to the computer. Refer to your computer Owner's Manual or contact your dealer for printer recommendations.

Getting On-Line with a Control Panel

At the protected premises, the control panel must be connected to the existing telephone line (refer to the *SECTION 3: Installing the Control*). No programming of the panel is required before downloading to an initial installation unless you are performing an unattended download.

When establishing a connection between the computer and the control panel, the following occurs:

Stage	What Happens
1	The computer calls up the control panel. (The phone number for each customer must be entered into the customer's account file on the computer.)
2	The control panel answers the phone call at the pre-programmed ring count and executes a handshake with the computer.
3	The computer sends a request for callback to the control, unless callback is not required.
4	The panel acknowledges the request and hangs up. During the next few seconds, the control processes the request, making sure certain encrypted information received from the computer matches its own memory.
5	Upon a successful match, the control panel seizes the phone line and calls the computer back, unless callback is not required. (The phone number to which the computer's modem is connected must be programmed into the control field *35.)
6	The computer answers, usually by the second ring, and executes a handshake with the panel.
7	The panel then sends other default information to the computer. If this information matches the computer's information, a successful link is established. The system is now "on-line" with the computer.

To download a control without programming any information, perform the following steps:

Step	Action
1	Enter the Installer Code + [#] + [5] . The panel temporarily enables a ring count of 5 and sets the Download Callback option to "1" (callback not required).
2	From the computer, call the panel using the downloader software set to "First Communication" Mode. The downloader establishes a session with no callback. The panel information can then be downloaded.

On-Line Control Functions

The following functions can be performed while on-line with a control panel (see field *37):

- Arm the system in the AWAY Mode; disarm the system
- Bypass a zone
- Force the system to accept a new program download
- Shut down communication (dialer) functions (for nonpayment of monitoring fees in an owned system)
- Shut down all security system functions (for nonpayment for a leased system)
- Inhibit local keypad programming (prevents takeover of your accounts)
- Leave a message for customer

NOTE: Messages sent to the control panel from the downloader will be viewable at ALL partitions.

- Command the system to upload a copy of its resident program to the office
- Read: arming status, AC power status, list of faulted zones, list of bypassed zones, 1024 event log, list of zones currently in alarm, list of zones currently in trouble, and ECP equipment list
- Set the real-time clock



- Alarms and Trouble responses and reports are disabled during actual uploading or downloading sessions. If you are on-line, but not actively uploading or downloading, all alarms report immediately. All other reports are delayed until you complete the session.
- The keypads remain active when on-line with a control, but are inactive during actual uploading or downloading sessions.

Direct-Wire Downloading

The VISTA-32FB can be downloaded without using a modem or telephone line by using a 4100SM Serial Module and Compass Downloading Software. The direct-wire downloading connection is to be temporary, and is not part of the permanent installation. Direct-wire downloading is meant as a tool for the installer during the installation process.



The connections between the control and the 4100SM are different than those shown in the 4100SM Installation Instructions. See Figure 7-1 for the correct connections. In addition, in place of the green wire, referred to in step 2 of the "IN CASE OF DIFFICULTY" section of the 4100SM Instructions, use the violet wire instead.

Connector J2 on the main PC board (see the *Summary of Connections* diagram on the inside back cover of this manual) is intended to be interfaced to either a local serial printer (see *Event Log Connections* in SECTION 3 *Installing the Control*) or a computer. Make connections to a computer as shown below. **Note that the violet wire connection for a computer differs from that used when connecting a serial printer.**

NOTE: The 4100SM Serial Module must be removed from the J2 Header at the completion of downloading.

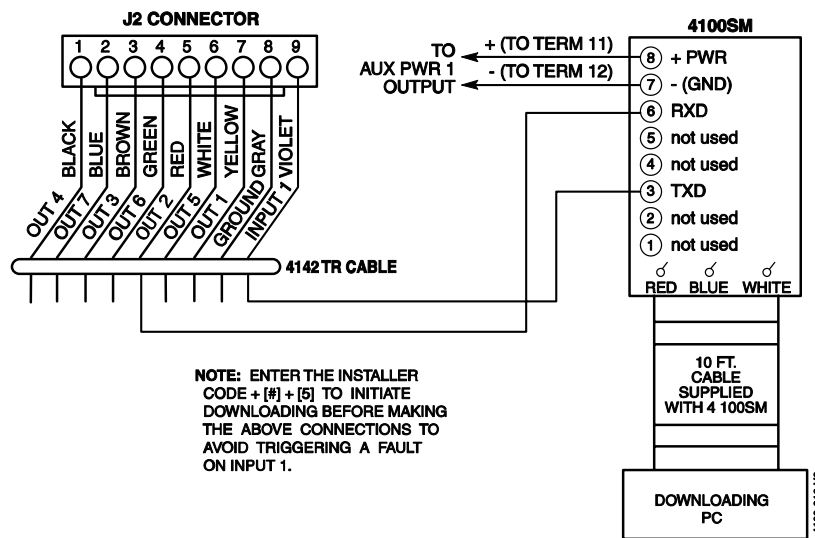

Figure 7-1: Direct-Wire Downloading Connections

Telco Handoff

Telco handoff is another method of getting on-line with the downloader. The installer or customer enters the **User Code** + [#] + [1], while on the phone line with the computer's modem phone line. The customer will get cut-off and the panel and download computer will establish a connection.

Setting the Real-Time Clock

General Information

This system provides a real-time clock, which must be set in order for the system's event log to keep track of events by time and date. It must also be set in order to execute scheduling programs (Time-Driven events).



Use a 6160/6160CR-2 alpha keypad to set the real-time clock, or set the clock via the downloader software. Only users with Installer or Master authority level can set the clock.

Setting the Time and Date

To set the real time clock, perform the following steps:

Step	Action
1	<p>Enter Installer or Master Code + [#] 63. Typical display shows:</p> <div style="border: 1px solid black; padding: 5px; width: fit-content; margin: 5px 0;"> <p>TIME/DATE — THU 12:01 AM 01/01/90</p> </div> <p>The day of the week is automatically calculated based on the date entered. Time and date entries are made by simply entering the appropriate hour, minute, month, day and year.</p> <p>Press [*] to move the cursor to the right of the display, to the next position. Press [#] to move the cursor to the left of the display, to the previous position.</p>
2	<p>Enter the correct hour. Then press [*] to move to the "minutes" field.</p>

Step	Action
3	<p>Enter the correct minutes. Press [*] to move to the AM/PM position.</p>
4	<p>Press any key 0-9 to change AM to PM, or PM to AM. Press [*] to move cursor to the "month" field position.</p>
5	<p>Enter the correct month using a 2-digit entry. Press [*] to move cursor to the "day" field position.</p>
6	<p>Enter the correct day using a 2-digit entry. Press [*] to move cursor to the "year" field position.</p>
7	<p>Enter the correct year. Press [*] to exit the real-time clock edit mode.</p>

User Access Codes

General Information

The VISTA-32FB system allows a total of 75 security access codes to be allocated. Each security access code is identified by a user ID number. **Regardless of the number of partitions each code has access to, it occupies only one user slot in the system. If a particular code is not used in all partitions, that user ID number cannot be used again.**

The Quick Arm feature can also be programmed (partition-specific program field *29). The Quick Arm feature allows the user to arm the system by pressing the [#] key instead of the security code. The security code must always be entered to disarm the system.



A user code other than the installer code must be programmed in order for the Quick Arm feature to function.

User Codes and Levels of Authority

Each user of the system can be assigned a level of authority, which authorizes the user for certain system functions. A user can have different levels of authority within different partitions

Use the “View Capabilities” keypad function (**User Code + [*] + [*]**) to view the partitions and authority levels for which a particular user is authorized. These levels are described below.

Level 0: Installer (User 1) Code

- Programmed in field *00 (default = 5-1-4-0). Installer Open/Close reporting selected in field *39.
- Can perform all system functions (arm, disarm, bypass, etc.), but **cannot disarm** if armed by another code (or by Quick Arm).
- Can add, delete, or change all other codes, and can select Open/Close reports for any user.
- Is the only code that can be used to enter program mode. The Installer Code can be prevented from re-entering the Program Mode by exiting using *98.
- Must program at least one Master Code during initial installation. Master Codes are codes intended for use by the primary user(s) of the system.

Level 1: Master Codes

- Can perform all normal system functions.
- Can be used to assign up to 74 lower-level codes, which can be used by other users of the system.
- Cannot assign anybody a level of 0 or 1.
- May change own user code.
- Can add, delete, or change Manager or Operator Codes. Each user’s code can be individually eliminated or changed at any time.
- Open/Close reporting is automatically the **same** as that of the Master who is adding the new user.

Level 2: Manager Codes

- Can perform all system functions (arm, disarm, bypass, etc.) programmed by Master.
- May add, delete, or change other users of the system below this level (Manager cannot assign anybody a level of 0, 1, or 2).
- May change own user code.
- Open/Close reporting is automatically the **same** as that of the Manager who is adding the new user.

Levels 3-5: Operator Codes

- Can operate a partition, but cannot add or modify any user code (see table below).

Level	Title	Functions Permitted
3	Operator A	Arm, Disarm, Bypass
4	Operator B	Arm, Disarm
5	Operator C	Arm, Disarm only if armed with same code

- Operator C (sometimes known as the Babysitter Code) cannot disarm the system **unless** the system was armed with that code. This code is usually assigned to persons who may need to arm and disarm the system at specific times only (e.g., a babysitter needs to control the system only when babysitting).

Level 6: Duress Codes

- Sends a silent alarm to a central monitoring station if the user is being forced to disarm (or arm) the system under threat (system must be connected to a central station).
- When the system’s Auxiliary Voltage Triggers are connected to another communication’s media (Derived Channel/Communications Device), note that duress is signaled on the same trigger that signals silent panic (whereas duress has its own unique report when digitally communicated).
- Assigned on a partition-by-partition basis, and can be any code or codes desired.



Duress Reporting NOTE: A non-zero report code for zone 992 (duress) must be programmed, and partition-specific field *85 duress location enabled, to enable Duress reporting.

- The Duress report-triggering logic activates on the 5th key depression (such as OFF), not the 4th key depression (last digit of code). Duress reports are not triggered if the 5th key is a [*], such as when you perform a GOTO or view the capabilities of a user.

General Rules on Authority Levels and Changes

The following rules apply to users when making modifications within the system based on the user code authority levels:

- Master Codes and all lower-level codes can be used interchangeably when performing system functions within a partition (a system armed with a user’s temporary code can be disarmed with the Master Code or another user’s temporary code), except the Operator Level C Code described above.
- A user may not delete or change the user code of the SAME or HIGHER authority than that which he is assigned.
- A user (levels 0, 1 and 2 only) may only ADD users to a LOWER authority level.
- A user may assign other users access to only those partitions to which he himself has access.
- A user code can be DELETED or CHANGED only from within the partition it was created in.
- User numbers must be entered in 2 digits. Single-digit user numbers must, therefore, always be preceded by a “0” (e.g., 03, 04, 05, etc.). Make sure the end user understands this requirement. Temporary codes are entered as 4-digit numbers.

Open/Close Reporting Note: When a user is added, the system prompts for Open/Close reporting capability only if the installer is adding the new user. When a Master or Manager adds a new user, the new user’s Open/Close reporting is the same as that of the Master or Manager who is adding the user. If Open/Close reports are required to be selectable by the Master or Manager, the Installer should assign two Master or Manager user codes: one with Open/Close reporting enabled, and one without.

Note that Open/Close reporting of Quick Arm is enabled if User 02 is enabled for Open/Close reporting, and that Quick Arm reports as User 00. In order for Quick Arm reports to be sent for all partitions, User 02 must have authority and Open/Close must be enabled for all partitions. If a code with access to all partitions is not desired, it is suggested that user 02 be assigned authority level 5 in all partitions, and that the code be kept secret. Authority level 5 cannot disarm the system unless armed by that user.



ADEMCO Contact ID format is capable of reporting Users 01-75 uniquely. If any other report format is used, only user numbers 01 – 015 can uniquely report to the central station. Users 16 – 75 will report as User 15.

Multiple Partition Access

Each user is programmed for a primary (home) partition. A user can also be given access to operate one or more additional partitions. Within each partition, each user may be programmed to have different levels of authority. For example, User 03, the VP of Engineering, could be assigned to work within the Engineering Department (Partition 1) of ABC Manufacturing. Because he needs the full capabilities in his area, he is assigned as a MASTER with Level 1 authority.

He must also be able to gain access to the manufacturing area (Partition 2) on an emergency basis. You can set this up easily by requesting that he also be assigned to Partition 2, with a level of authority set lower, such as Level 4 (OPERATOR Level B).

The control automatically assigns him the same user number within Partition 2.

EXAMPLE OF MULTIPLE PARTITION ACCESS

Part 1	Part 2
User 3	User 3
Level 1	Level 4
Master	Oper B

In the above example, User 3 has MASTER authority in Partition 1 and OPERATOR B authority in Partition 2. His user number is the same for both partitions. Note that if a user number is already being used in a partition, the system will automatically assign a new user an unused number.

Adding a Master, Manager, or Operator Code

Enter **Installer Code**[†] + [8] + **new user no. (02-75) + new user's code**

[†]Or Master or Manager Code, but the code must be a higher level of authority than the code being changed (e.g., a Manager Code can add an Operator-level Code, but cannot add a Master or another Manager Code). Keypad prompts for the authority level for this user.



During user code entry, normal key depressions at other keypads in a partition are ignored. However, panic key depression causes an alarm and terminates user entry.

PROMPT	EXPLANATION
User Number = 03 Enter Auth. Level	Enter the level number as follows: 1 = Master 2 = Manager 3 = Operator Level A 4 = Operator Level B 5 = Operator Level C 6 = Duress Keypad then prompts for Open/Close reporting option for this user.
Open/Close Rep.? 0 = NO , 1 = YES	Press 0 (NO) or 1 (YES), depending on whether or not arming/disarming by this user will trigger Opening and Closing reports. This prompt appears only if the Installer Code is used to add a user.
Group Bypassing? 0 = NO , 1 = YES	Enter 1 (YES) to allow this user to perform group bypasses. Enter 0 (NO) this user will not be able to perform group bypasses. NOTE: In addition to enabling the user for group bypassing, the user must also have access to the partition(s) containing the zones being bypassed and have global arming capability.
Access Group? Enter 0-8	If access schedules have been programmed, this prompt appears. Enter the user's access group number (1-8) if this user should have limited access to the system. Enter 0 if no access group should be assigned.
RF Button ? 0=NO , 1=YES	Not Used.
Multi-Access ? 0 = NO , 1 = YES	Press 0 (NO) if the user is to have access to this partition only. Press 1 (YES) if the user is to have access to more than one partition. If NO, the program exits this mode. If YES, the keypad prompts for the Global Arm option for this user.
Global Arm ? 0 = NO , 1 = YES	Press 0 (NO) or 1 (YES), depending on whether this user will be allowed to arm more than one partition via Global Arm prompts (described in the <i>VISTA-32FB User Guide</i>). The keypad now prompts for the user's access to the next partition.
Part. 2 – SHOP ? 0 = NO , 1 = YES	Press 0 (NO) or 1 (YES), depending on whether this user will have access to the displayed partition number. If NO, the keypad displays this prompt for the next partition number in sequence. If YES, the keypad prompts for the following: <ul style="list-style-type: none"> User's authority level in the displayed partition (see Authority Level prompt above). Open/Close option for this user in the displayed partition (see Open/Close prompt above). Global Arm option for this user in the displayed partition. When all partitions have been displayed, the keypad will scroll through all partitions to which access has been assigned, and will display the user number, authority level, open/close and global arm options that were programmed for each partition to which the user was granted access. For example:
Part. 1 A0* WHSE User 03 Auth=3G.	Note that the "G" following the authority level indicates that the global arm feature is enabled for this user in the displayed partition, and that the period at the end of the second line indicates Open/Close reporting is enabled for this user in the displayed partition. The "T" indicates the partition from which the user may be changed or deleted.

Changing a Master, Manager, or Operator Code

Enter **Installer Code** * + [8] + **new user no. (02-75)** + **new user's code**

*Or Master or Manager Code, but the code must be a higher level of authority than the code being changed (e.g. a Manager Code can add an Operator-level Code, but cannot add a Master or another Manager Code).

PROMPT	EXPLANATION
User Number = 03 NEW USER?	The system detects that the user number is already assigned, and prompts if this is a new user. Press 0 (NO). The system then confirms that the change is allowed based on authorization level.

Adding an RF Key to an Existing User

To add an RF key to an existing user, or to change a user's global arm option, first delete that user's code, then re-add the user code as described in the "Adding a Master, Manager, or Operator Code" paragraph.

Deleting a Master, Manager, or Operator Code

Enter **your code** * + [8] + **new user no. (02-75)** + **your code again**

*Or Master or Manager Code, but the code must be a higher level of authority than the code being changed (e.g. a Manager Code can add an Operator-level Code, but cannot add a Master or another Manager Code).

PROMPT	EXPLANATION
OK TO DELETE 03? 0=NO 1=YES	The system prompts to confirm that you want to delete this user. Press 0 (NO) or 1 (YES). If you selected "yes," that user's code is removed from all partitions to which it was assigned, and all authorization levels and other information about that user are deleted. Note that only a user with a higher authority level can delete a user. A user cannot delete their self.



A user code can be deleted only from the partition through which it was entered. If an attempt is made to delete from another partition, the message "User [XX] Not Deleted" is displayed.

Exiting the User Edit Mode

Press either [*] or [#], or don't press any key for 10 seconds.

Testing the System

Battery Test

When AC power is present, the VISTA-32FB runs a brief battery test every 60 seconds to determine if there is a battery connected, and runs an extended battery test every 4 hours to check on the battery's condition.

If the VISTA-32FB finds that the battery voltage is low (less than approximately 11.5V), it initiates a keypad "SYSTEM LOBAT" display and a rapid keypad beeping sound. It also sends a Low Battery report to the central station (if programmed). The keypad is cleared by entering any security code + OFF, and a Restore report is sent to the central station if the situation has been corrected.

Dialer Test

The VISTA-32FB may be programmed to automatically transmit test reports to a central station at intervals ranging from once per hour to once per 9999 hours (field *27).

UL requires the test report to be transmitted at least once every 24 hours. The system can be programmed to send the first report at any time of the day, or on any day of the week (field *83).

Fire Drill Test (Code + [#] + 69)

This test causes fire Notification Appliance Circuits (or any NAC having a non-zero response type programmed) to be activated (in either steady or pulsing manner, as programmed in field 3*15, for the purpose of conducting a fire drill or bell test. This test can only be activated by the installer or master users from partition 1 keypads by entering the corresponding security code + [#] + 69. The burglary portion of the system must be disarmed.

Keypads display "FIRE DRILL ACTIVE" while the test is active. The test is stopped by entering any user code + OFF.

The system continues to monitor all 24-hour type zones (fire, panic, etc.) and ends the test if any of these zone types produce an alarm condition.

This test should be conducted at periodic intervals, as determined by the local authority having jurisdiction.

One-Man Fire Walk-Test (Code + [#] + 68)

This test causes the system to sound console beeps and Notification Appliance Circuit dings in response to fire zone faults (zone type 9, 16 & 17) for the purpose of allowing proper zone operation to be checked without triggering alarms. Note that the system will not be operational as an alarm system (i.e., cannot sense alarms) while this test is active. The test can only be activated by the installer by entering the Installer's Code and pressing [#] + 68 while the burglary portion of the system is disarmed.

This test should be conducted at periodic intervals, as determined by the local authority having jurisdiction.



When testing non-latching devices, such as heat detectors, be sure to keep the device faulted until the system responds with the keypad beep or siren sound. If the device is faulted only momentarily, the system may not respond to the fault.

When this test is first activated, the system will display:

PROMPT	EXPLANATION
USE BELL DING? 0=NO 1=YES	Enter 1 (YES) to have the fire Notification Appliance Circuits associated with each point sound for 3 seconds when a point is faulted. Enter 0 (NO) if only keypad sounders are desired. The next prompt will be displayed.

PROMPT	EXPLANATION
<p>AUTO-TEST DET? 0=NO 1=YES</p>	<p>Enter 1 (YES) to have the system automatically test all polling loop points with a fire response type 9 or 16. Other fire zones will have to be tested manually. Enter 0 (NO) to test every point manually. The next prompt will be displayed.</p>



For true detector sensitivity tests, and for compliance with fire codes, you must enter **0 (NO)** to this question.

<p>LOG RESULTS? 0=NO 1=YES</p>	<p>Enter 1 (YES) to have the system log each point as it is tested. A list of untested points will also be logged. Enter 0 (NO) if you do not want to log the results. The next prompt will only be displayed if Contact ID report format has been selected.</p>
<p>C.S. TRANSMIT? 0=NO 1=YES</p>	<p>Enter 1 (YES) to have the results of the test sent to the central station. This report will consist of a list of points that have been tested followed by a list of points that have not been tested. Enter 0 (NO) if you do not want to report the results. A Walk-Test Start and Walk-Test End report will be sent in either case (if programmed).</p>

When the Test Mode is activated, the system will sound fire Notification Appliance Circuits (or any NAC having a non-zero response type programmed in the #93 *Menu Mode*) for 3 seconds. The system will also send a Start of Walk-Test message to the central station, and will light all keypad indicators (except the ARMED LED) and display window segments to verify that they are working properly. The keypads will then display Fire Walk-Test in Progress and will sound a single beep every 15 seconds while this test is active.

The system will build a list of all the fire zones (response types 9, 16, 17, 18) that need to be tested. These points will be scrolled on the display. For each point, the keypad will display "UNTST XXX," where XXX is the point number, followed by an alpha descriptor for the point.

If the auto-test option has been selected, the control panel will attempt to automatically test all of the polling loop points that have a zone response type of 9 or 16. For points that must be manually tested, fault and reset each fire alarm sensor in turn.

Each action should cause keypads to beep and fire Notification Appliance Circuits to ding. The keypads will display the zone number and the associated alpha descriptor while the zone remains faulted. The system automatically issues a smoke detector power reset about 10 seconds after it finds a fault on one of these zones, to allow faulted detectors to be reset.



The system will automatically perform the smoke detector reset on zones 001 & 002, if programmed for fire, and on the auxiliary relay and any other output device (relay) that is programmed for smoke detector reset.

To end the test, enter any security code and press OFF. An End of Walk-Test message will be sent to the central station (if programmed). Note that the test will automatically end if no faults are detected within a 1-hour time period.

Burglary Walk-Test

This test causes the system to sound keypad beeps in response to faults on zones for the purpose of allowing proper zone operation to be checked without triggering alarms. Any user can activate this test by entering the corresponding security code and pressing TEST while the burglary portion of the system is disarmed. UL requires that this test be conducted on a weekly basis.

When this test is first entered, the system activates the alarm output for 3 seconds. The system sends a Start of Walk-Test message to the central station. The keypad displays "Burg Walk Test in Progress" and sounds a single beep every 15 seconds while the test remains active.

Open and close each protected door and window in turn. Each action should produce three beeps from the keypad. Walk in front of any motion detectors. Listen for three beeps when the detector senses movement. The keypad displays the zone number and alpha descriptor while a door or window remains open or while a detector remains activated. The system automatically issues a Zone 008 Glassbreak Detector Power Reset about 10 seconds after it finds a fault on this zone, to allow faulted detectors to be reset.

To end this test, enter any security code and press OFF. An End of Walk-Test message is sent to the central station.

Armed Burglary System Test



- Alarm messages are sent to the central station during the armed tests. Notify the central station that a test will be in progress.
- A display of “COMM FAILURE” indicates a failure to communicate (no kiss-off by the receiver at the central station). If this occurs, verify that the phone line is connected, the correct report format is programmed, etc.

To perform an armed burglary test, proceed as follows:

Step	Action
1	Notify the central station that a test of the system is being performed.
2	Arm the system.
3	Fault one or more zones.
4	Silence alarm sounder(s) each time by entering the code and pressing OFF. NOTE: The system must be rearmed after each code + off sequence.
5	Check that entry/exit delay zones provide the assigned delay times.

Step	Action
6	Check the keypad-initiated alarms, if programmed, by pressing the panic key pairs (* and #, 1 and *, and/or 3 and #). The word ALARM and a descriptor “999” are displayed for * and #. If [1] and [*] are pressed, “995” is displayed; if [3] and [#] are pressed, “996” is displayed.
7	If the system has been programmed for audible emergency, the keypad emits a loud, steady alarm sound. Silence the alarm by entering the security code and pressing OFF. If the system has been programmed for silent panic, there are no audible alarms or displays. A report is sent to the central station, however.
8	Notify the central station that all tests are finished, and verify results with them.

Testing Wireless Transmitters

Transmitter ID Sniffer Mode

Use the Transmitter Sniffer Mode to test that transmitters have all been properly programmed.



If a transmitter does not have its serial number “enrolled,” it will not turn off its zone number.

To enter the Transmitter ID Sniffer Mode, proceed as follows:

Step	Action
1	Enter Installer Code + [#] + [3] . The keypad displays all zone numbers of wireless units programmed into the system.
2	Fault each wireless zone, causing each device to transmit. As the system receives a signal from each of the transmitters, the zone number of that transmitter disappears from the display.
3	Enter Installer Code + OFF to exit the Sniffer Mode.

Go/No Go Test Mode

This mode assists in determining good mounting locations, and that the RF transmission has sufficient signal amplitude margin for the installed system.



- All partitions with wireless transmitters must be placed in the test mode for RF receiver sensitivity reduction (50%). Otherwise, the RF receiver remains at full strength.
- Make sure that all partitions are disarmed for this test.

To enter the Go/No Go Test Mode, proceed as follows:

Step	Action
1	Enter Installer Code + [5] .
2	Fault each wireless transmitter, causing each device to transmit. The keypad will beep three times if the signal is received.
3	If the keypad does not beep, reorient or move the transmitter to another location. Usually a few inches in either direction is all that is required.
4	Enter Installer Code + OFF to exit the Go/No Go Test Mode.

Trouble Conditions

Supervisory Messages

Display	Description
SUPV + Zone Number	This indicates that a fire supervisory condition exists on the zone number displayed. This means that the operation of the fire alarm system may be compromised.

Check or Trouble Messages

Display	Description
CHECK or TRBL (as per field 1*07)	This indicates that a problem exists on the zone number displayed. Zone trouble may be caused by one of the following conditions: <ul style="list-style-type: none"> • A hardwired fire zone is open (broken wire). • A Day/Night zone (zone type 5) is faulted. • A polling loop zone is not seen by the control panel. • A polling loop zone has been tampered (cover removed on a 4190). • A wireless zone has not checked in during the time programmed in field 1*31. • A 5800 Series transmitter has been tampered (cover removed).
CHECK 6XX XX = 01-32	This indicates a trouble on a 4204CF Supervised Notification Appliance Circuit (corresponding relay number 01-32).
CHECK 8XX XX = 00-30	This indicates a trouble on a peripheral device (connected to the panel's keypad terminals) of the corresponding device address (00-30).
CHECK 9XX XX = 00-99	This indicates that a system trouble exists (RF receiver, Notification Appliance Circuit, etc.).



If the problem has been corrected, enter an OFF sequence (**Security Code + OFF**) twice to clear the display.

Power Failure

Display	Description
AC LOSS POWER LED is off	This indicates that the system is operating on battery power only. Check to see that the circuit breaker for the branch circuit that your system's transformer is wired to has not been accidentally turned off. Instruct the user to call a service representative immediately if AC power cannot be restored.

Other System Messages

Display	Description
COMM FAILURE	Indicates a failure occurred in the telephone communication portion of your system.
LO BAT	Indicates a low-battery condition exists in the wireless transmitter displayed. Pressing any key silences the audible warning sound.
SYSTEM LO BAT	This indicates that a low-battery condition exists with the system's backup battery.
HSENS	Indicates a smoke detector with a high sensitivity level, which may cause a false alarm. The detector should be cleaned or replaced.
LSENS	Indicates a smoke detector with a low sensitivity level. The detector may not detect a smoke condition. The detector should be cleaned or replaced.
RCVR SETUP ERROR	Indicates the system has more wireless zones programmed than the RF receiver can support. If this is not corrected, none of the zones in the system will be protected. If additional wireless zones are desired, use an appropriate receiver.
MODEM COMM	This indicates that the control is on-line with a remote computer.

System Off-Normal Report

If programmed, an Off-Normal report is generated instead of the periodic test report if any of the following conditions are present at the time of the report:

- Fire trouble on any zone (zone types 9, 16, 17, 18)
- Fire supervisory present (zone type 18)
- Unrestored fire alarm on any zone
- Bypass of any fire zone
- A fault for any supervised fire Notification Appliance Circuit
- Bypass/disable of any supervised fire Notification Appliance Circuit
- Telco fault of either dialer line
- Bypass/disable of either dialer line
- Earth ground fault
- Bypass of earth ground supervisory zone
- Fault on LORRA "XMIT OK" signal (if enabled)
- LORRA trigger bypassed
- AC failure
- Low system battery
- Keypad supervision fault

The Off-Normal report is sent as follows:

- Contact ID: Code 608
- High Speed: Channel 3 of system report used (channel 9=6)
- Low Speed: Digits programmed in System Group #4 report codes

To the Installer

Regular maintenance and inspection (at least annually) by the installer and frequent testing by the user are vital to continuous satisfactory operation of any alarm system.

The installer should assume the responsibility of developing and offering a regular maintenance program to the user as well as acquainting the user with the proper operation and limitations of the alarm system and its component parts. Recommendations must be included for a specific program of frequent testing (at least weekly) to ensure the system's proper operation at all times.

Turning the System over to the User

Fully explain the operation of the system to the user by going over each of its functions, as well as the User's Manual supplied.

In particular, explain the operation of each zone (entry/exit, perimeter, interior, fire, etc.). Be sure the user understands how to operate any emergency feature(s) programmed into the system.

Contacting Technical Support

PLEASE, before you call Technical Support, be sure you:

- READ THE INSTRUCTIONS!
- Check all wiring connections.
- Determine that the power supply and/or backup battery are supplying proper voltages.
- Verify your programming information where applicable.
- Verify that all keypads and devices are addressed properly.
- Note the proper model number of this product, and the version level (if known) along with any documentation that came with the product.
- Note your Honeywell customer number and/or company name.

Having this information handy will make it easier for us to serve you quickly and effectively.

You may contact Technical Support via Toll-Free Fax. Please include your return fax number. You will receive a reply within 24 hours. You may also contact Technical Support via modem to ATLAS-BBS, Tech Support's Electronic Bulletin Board System. Replies are posted within 24 hours.

Technical Support:..... 1-800-645-7492 (8 a.m.-8 p.m. EST)
ATLAS-FAX FAXBACK Automated Fax Retrieval System:..... 1-800-573-0153
World Wide Web Address: http://www.security.honeywell.com

Using the Vista-32FB as a Slave Communicator

To use the Vista-32FB as a Slave Communicator connected to a Fire Alarm System, follow the setup below.

Wiring

Wire the Vista-32FB as shown in Figure xx below. Be sure to tag the wires at the Terminal Box to identify their connections between the Fire Alarm Panel and the Vista-32FB.

Programming

NOTE: An alpha keypad such as the 6160 is required to program the following.

1. Enter Installer Code + 8 + 0 + 0 for Programming Mode.
2. Enter *93 for Zone Programming Mode.
3. Program a zone (corresponding to zone input A) as zone type 09 (Fire), zone type 17 (Waterflow), zone type 18 (Fire Supervisory), or zone type 19 24-Hour Trouble) as applicable.
4. Program the applicable report code for the input zone on the Vista-32FB.
5. If using a keypad connected to the Vista-32FB and the Communicator will be unmanned, program field *77 (Auto Restore) for option 2 (restore troubles and fire alarms).
6. If using zone type 18, field 3*13 (Fire Supervisory Response to Open/Short) must be set to 1 to report Supervisory on short or open.

NOTES:

1. Do not use zone type 16 (Fire w/Verification) for the input zone for fire on the Vista-32FB. Use zone type 9 only.
2. Do not connect a bell, horns or strobes to the Vista-32FB. Annunciation will be provided by the Fire Alarm Panel.

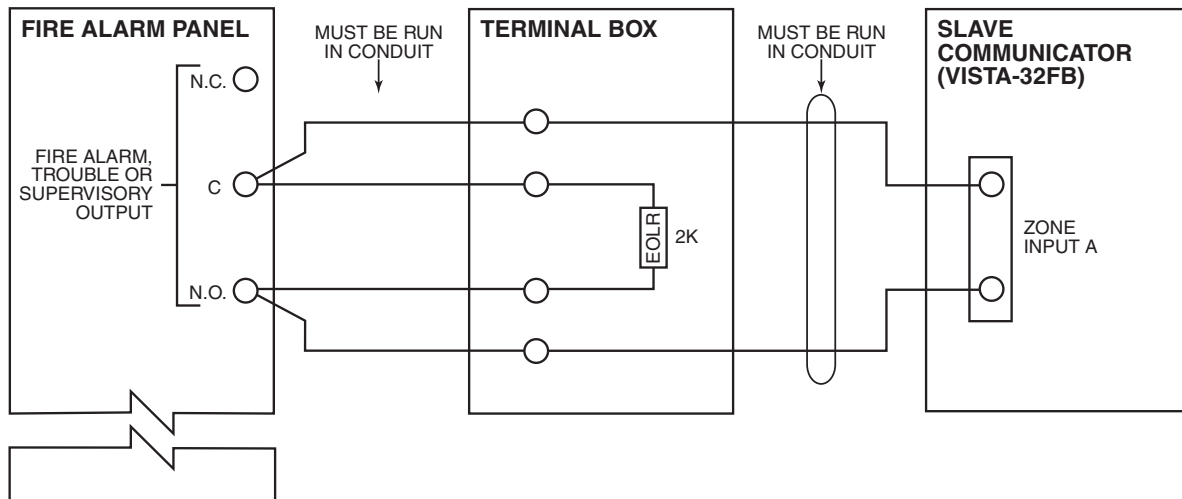

NOTE

Provide a suitable terminal box as the point of demarcation between the fire alarm panel and the Slave Communicator (Vista-32FB). Tag the wires at the Terminal Box to identify their connections between the Fire Alarm Panel and the Vista-32FB.

V32FB-002-V0

Figure 11-1: Slave Communicator Wiring Diagram

Sending Vista-32FB System Troubles to the Fire Alarm Panel

If using an alpha keypad on the Vista-32FB that is mounted next to the Main Fire System Operator Interface, it is not necessary to send Vista-32FB troubles to the Fire Alarm Control. If not using an alpha keypad on the Vista-32FB mounted next to the Main Fire System Operator Interface, troubles for AC loss, low battery, and communication failure must be sent to the Fire Alarm Control for local annunciation at the Fire System Operator Interface. To do this, connect a 4204CF relay to the VISTA-32FB and wire the relay outputs to input zones at the Fire Alarm panel as shown below.

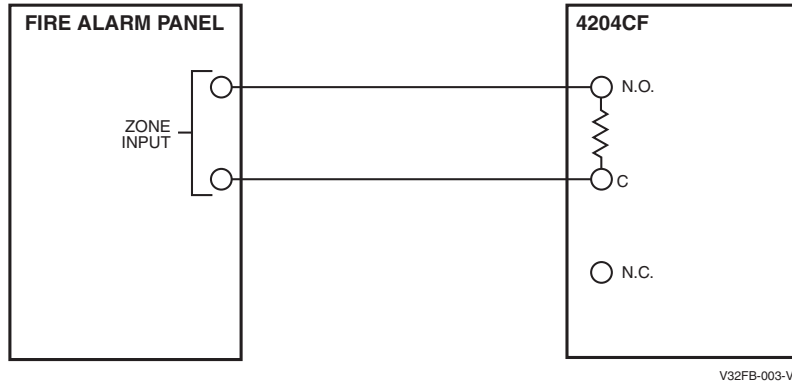

At the Vista-32FB, program the each relay in #93 output programming mode to activate on one of these conditions. The “Start” events for these outputs should be programmed as the following Zone Type/System Operations:

- 41 = AC Power Fail
- 42 = System low battery
- 43 = Communications failure

Select the same options for the “Stop” events. That will cause the outputs to revert to normal on the restoration of those events.

At the Fire Alarm panel, program these zones as supervisory or trouble zones. Do not program these zones to report back to the Vista-32FB. Instead, make sure report codes are enabled for these conditions in the Vista-32FB. The communicator will send these reports itself, and will randomize the AC loss report to the central station as required.

Regulatory Agency Statements

UL Installation Requirements

UL This system may be used in installations that require UL2050 compliance.

Commercial Burglary Requirements

1. All partitions must be owned and managed by the same person(s).
2. All partitions must be part of one building at one street address.
3. The audible alarm device(s) must be placed where it/they can be heard by all partitions.
4. The control cabinet must be protected from unauthorized access. This can be done by installing a tamper switch on the cabinet door (supplied with the attack-proof cabinet). Wire the selected device to zone 6. Program this zone for day trouble/night alarm (type 05) or 24-hour audible alarm (type 07) response. The 24-hour alarm response must be used for multiple partitioned systems.

UL864/NFPA Local Fire

1. Configure at least one Notification Appliance Circuit for supervision and wire polarized fire alarm indicators to it.
2. Size the battery for 24-hour backup.

UL864/NFPA Central Station and Remote Station Fire

1. Size the backup battery for 24-hour standby time.
2. For central station service, you may use the 7845i-ent communications device alone, the main dialer with a communications device, or the main dialer with the 5140DLM Backup Dialer Module. For remote station service, you must use the main dialer with the 5140DLM Backup Dialer Module.
3. When the main dialer is used, enable it (field 3*30) and connect it to a telephone line. Assign a 24-hour trouble response (type 19) to system Zone 974 to enable main dialer supervision. The control panel will activate the trouble trigger when it detects a main dialer supervision fault.
4. When the backup dialer is used, install it on the control panel's PCB shield as indicated in the *Summary of Connections* diagram. Enable it (field 3*30) and connect it to a separate telephone line. Assign a 24-hour trouble response (type 19) to system Zone 975 to enable backup dialer supervision.
5. When the dialer is used, program it to send fire alarm, fire supervisory (if used), trouble, AC loss, low battery, normal dialer test, and off-normal dialer test reports. Field *27 must be set to "024" maximum so that test reports are sent at least once every 24 hours.
6. If a secondary number is programmed, set the maximum number of dialer retries to 3, 4, or 5 in field 3*21.

UL609 Local Mercantile Premises/Local Mercantile Safe & Vault

1. All zones must be configured for EOLR supervision (*41=0). If 4190SN V-Plex devices are used, set field *24 to "0" to enable tamper detection.
2. Attach a Listed door tamper switch to protect the cabinet door. Wire the selected device to Zone 6. Program this zone for day trouble/night alarm (type 05) or 24-hour audible alarm (type 07) response. The 24-hour alarm response must be used for multiple partitioned systems. Enable field 3*17 so that the system responds to a ground fault on that zone in accordance with the zone type rather than a ground fault response.
 - 2A. For safe and vault installations, an additional Listed tamper switch must be installed on the cabinet backbox to protect the cabinet from being removed from the wall. This device must also be connected to zone 6.
(Also see *Mounting the Cabinet* in *SECTION 3: Installing the Control*).
3. Entry delays must not exceed 45 seconds, and exit delays must not exceed 60 seconds.
4. All unused knockouts must be plugged (use the supplied disc plugs and carriage bolts).
5. Must be used with a Listed burglar alarm sounding device/housing. Depending on the application, a compatible Listed sounding device enclosure may also be required.

UL365 Police Station Connected Burglar Alarm

Follow the instructions for UL609 local installations given above.

For Systems without Line Security:

- You may use the control panel's main dialer alone, or the 7845i-ent, 7845-GSM or 7845i-GSM Communications Device alone.
- When using the dialer, program it to send Burglary Alarm, Low Battery and Communicator Test reports. Field *27 must be set to "0024" (or less) so that test reports are sent at least once every 24 hours.

For Systems with Line Security:

- The dialer must be used in conjunction with a secondary dialer or 7845i-ent Communications Device.
- The system must be programmed for dual reporting.

UL1610 Central Station Burglary Alarm

Follow the instructions for UL365 local installations stated above, and follow the additional guidelines below.

For Systems without Line Security:

- You must use the control panel's main dialer in conjunction with a 5140DLM, 7845i-ent, 7845i-GSM, or 7845GSM Communications Device.
- Program the dialer to send Burglary Alarm, Trouble, Opening/Closing, and Low Battery reports.

For Systems with Line Security:

- Follow the instructions for Systems without Line Security, but note that only a secondary phone line or a 7845i-ent may be used as the secondary Communications Device.
- The system must be programmed for dual reporting.

FEDERAL COMMUNICATIONS COMMISSION (FCC) STATEMENTS

The user shall not make any changes or modifications to the equipment unless authorized by the Installation Instructions or User's Manual. Unauthorized changes or modifications could void the user's authority to operate the equipment.

CLASS B DIGITAL DEVICE STATEMENT

NOTE: This equipment has been tested and found to comply with the limits for a Class B digital device, pursuant to part 15 of the FCC Rules. These limits are designed to provide reasonable protection against harmful interference in a residential installation. This equipment generates, uses and can radiate radio frequency energy and, if not installed and used in accordance with the instructions, may cause harmful interference to radio communications. However, there is no guarantee that interference will not occur in a particular installation. If this equipment does cause harmful interference to radio or television reception, which can be determined by turning the equipment off and on, the user is encouraged to try to correct the interference by one or more of the following measures:

- Reorient or relocate the receiving antenna.
- Increase the separation between the equipment and receiver.
- Connect the equipment into an outlet on a circuit different from that to which the receiver is connected.
- Consult the dealer or an experienced radio/TV technician for help.

INDUSTRY CANADA (IC) STATEMENTS

This device complies with RSS210 of Industry Canada. Operation is subject to the following two conditions: (1) This device may not cause harmful interference, and (2) This device must accept any interference received, including interference that may cause undesired operation.

This Class B digital apparatus complies with Canadian ICES-003.

Cet appareil numérique de la classe B est conforme à la norme NMB-003 du Canada.

IN THE EVENT OF TELEPHONE OPERATIONAL PROBLEMS

In the event of telephone operational problems, disconnect the control panel by removing the plug from the RJ31X (CA38A in Canada) wall jack. We recommend that you demonstrate disconnecting the phones on installation of the system. Do not disconnect the phone connection inside the control panel. Doing so will result in the loss of your phone lines. If the regular phone works correctly after the control panel has been disconnected from the phone lines, the control panel has a problem and should be returned for repair. If upon disconnection of the control panel, there is still a problem on the line, notify the telephone company that it has a problem and request prompt repair service. The user may not under any circumstances (in or out of warranty) attempt any service or repairs to the system. It must be returned to the factory or an authorized service agency for all repairs.

FCC PART 68 NOTICE

This equipment complies with Part 68 of the FCC rules. On the front cover of this equipment is a label that contains, among other information, the FCC registration number and ringer equivalence number (REN) for this equipment. If requested, this information must be provided to the telephone company.

This equipment uses the following jacks:

An RJ31X is used to connect this equipment to the telephone network.

The REN is used to determine the quantity of devices that may be connected to the telephone line. Excessive RENs on the telephone line may result in the devices not ringing in response to an incoming call. In most, but not all areas, the sum of the RENs should not exceed five (5.0). To be certain of the number of devices that may be connected to the line, as determined by the total RENs, contact the telephone company to determine the maximum REN for the calling area.

If this equipment causes harm to the telephone network, the telephone company will notify you in advance that temporary discontinuance of service may be required. If advance notice is not practical, the telephone company will notify the customer as soon as possible. Also, you will be advised of your right to file a complaint with the FCC if you believe necessary.

The telephone company may make changes in its facilities, equipment, operations, or procedures that could affect the operation of the equipment. If this happens, the telephone company will provide advance notice in order for you to make the necessary modifications in order to maintain uninterrupted service.

If trouble is experienced with this equipment, please contact the manufacturer for repair and warranty information. If the trouble is causing harm to the telephone network, the telephone company may request that you remove the equipment from the network until the problem is resolved.

There are no user serviceable components in this product, and all necessary repairs must be made by the manufacturer. Other repair methods may invalidate the FCC registration on this product.

This equipment cannot be used on telephone company-provided coin service. Connection to Party Line Service is subject to state tariffs.

This equipment is hearing-aid compatible.

When programming or making test calls to an emergency number, briefly explain to the dispatcher the reason for the call. Perform such activities in the off-peak hours, such as early morning or late evening.

CANADIAN EMISSIONS STATEMENTS

This Class B digital apparatus complies with Canadian ICES-003

NOTICE

The Industry Canada Label identifies certified equipment. This certification means that the equipment meets telecommunications network protective, operational and safety requirements as prescribed in the appropriate Terminal Equipment Technical Requirements document(s). The Department does not guarantee the equipment will operate to the user's satisfaction.

Before installing this equipment, users should ensure that it is permissible to be connected to the facilities of the local telecommunications company. The equipment must also be installed using an acceptable method of connection. The customer should be aware that compliance with the above conditions may not prevent degradation of service in some situations.

Repairs to certified equipment should be coordinated by a representative designated by the supplier. Any repairs or alterations made by the user to this equipment, or equipment malfunctions, may cause the telecommunications company to request the user to disconnect the equipment.

Users should ensure for their own protection that the electrical ground connections of the power utility, telephone lines, and internal metallic water pipe system, if present, are connected together. This precaution may be particularly important in rural areas.

Caution: Users should not attempt to make such connections themselves, but should contact an appropriate electric inspection authority, or electrician, as appropriate.

NOTICE: The **Ringer Equivalence Number (REN)** assigned to each terminal device provides an indication of the maximum number of terminals allowed to be connected to a telephone interface. The termination on an interface may consist of any combination of devices subject only to the requirement that the sum of the Ringer Equivalence Numbers of all the devices does not exceed 5.

AVIS

L'étiquette d'Industrie Canada identifie le matériel homologué. Cette étiquette certifie que le matériel est conforme aux normes de protection, d'exploitation et de sécurité des réseaux de télécommunications, comme le prescrivent les documents concernant les exigences techniques relatives au matériel terminal. Le Ministère n'assure toutefois pas que le matériel fonctionnera à la satisfaction de l'utilisateur. Avant d'installer ce matériel, l'utilisateur doit s'assurer qu'il est permis de le raccorder aux installations de l'entreprise locale de télécommunication. Le matériel doit également être installé en suivant une méthode acceptée de raccordement. L'abonné ne doit pas oublier qu'il est possible que la conformité aux conditions énoncées ci-dessus n'empêche pas la dégradation du service dans certaines situations.

Les réparations de matériel homologué doivent être coordonnées par un représentant désigné par le fournisseur. L'entreprise de télécommunications peut demander à l'utilisateur de débrancher un appareil à la suite de réparations ou de modifications effectuées par l'utilisateur ou à cause de mauvais fonctionnement.

Pour sa propre protection, l'utilisateur doit s'assurer que tous les fils de mise à la terre de la source d'énergie électrique, de lignes téléphoniques et des canalisations d'eau métalliques, s'il y en a, sont raccordés ensemble. Cette précaution est particulièrement importante dans les régions rurales.

Avertissement : L'utilisateur ne doit pas tenter de faire ces raccordements lui-même; il doit avoir recours à un service d'inspection des installations électriques, ou à un électricien, selon le cas.

AVIS : L'indice d'équivalence de la sonnerie (IES) assigné à chaque dispositif terminal indique le nombre maximal de terminaux qui peuvent être raccordés à une interface. La terminaison d'une interface téléphonique peut consister en une combinaison de quelques dispositifs, à la seule condition que la somme d'indices d'équivalence de la sonnerie de tous les dispositifs n'excède pas 5.

Summary of System Commands

User Code Commands	<p>Add A User Code = User Code + 8 + New User Number + New User's Code Change a Code = User Code + 8 + User Number + New User's Code Delete a User's Code = Your User Code + 8 + User Number to Be Deleted + Your Code Again View User Capability = User's Code + [*] + [*] Set Real-Time Clock (Installer, Master Only) = Code + [#] + 63</p>												
Programming Commands	<p>Site Initiated Download = User Code + [#] + 1. Direct-Wire Download Enable = User Code + [#] + 5. Enter Program Mode = Installer Code + 800. Enter Interactive Program Mode = Installer Code + 800 + [#] + 93 Exit Program Mode = *99 or *98.</p>												
Event Logging Commands	<p>Event Log Display = Code + [#] + 60 (Installer or Master Only) Event Log Print = Code + [#] + 61 (Installer or Master Only) Clear Event Log = Code + [#] + 62 (Installer or Master Only)</p>												
Wireless System Commands	<p>House ID Sniffer Mode = Code + [#] + 2 (Installer Only) Transmitter ID Test = Code + [#] + 3 (Installer Only) Go/No Go Test = Code + 5 (Test Key)</p>												
Additional Commands	<table border="1"> <tr> <td data-bbox="407 1052 808 1087">Partition GOTO</td> <td data-bbox="808 1052 1464 1087">User Code + [*] + Partition Number 0-2.</td> </tr> <tr> <td data-bbox="407 1087 808 1123">GOTO Home Partition</td> <td data-bbox="808 1087 1464 1123">User Code + [*] + 0.</td> </tr> <tr> <td data-bbox="407 1123 808 1243">Panics</td> <td data-bbox="808 1123 1464 1243">[*] + 1 or A Key (Zone 995). [*] + [#] or B Key (Zone 999). [#] + 3 or C Key (Zone 996).</td> </tr> <tr> <td data-bbox="407 1243 808 1278">View Downloaded Messages</td> <td data-bbox="808 1243 1464 1278">Press 0 for 5 Seconds.</td> </tr> <tr> <td data-bbox="407 1278 808 1314">Display All Zone Descriptors</td> <td data-bbox="808 1278 1464 1314">Press [*] for 5 Seconds.</td> </tr> <tr> <td data-bbox="407 1314 808 1367">Display User Self Help</td> <td data-bbox="808 1314 1464 1367">Hold Any Key for 5 Seconds.</td> </tr> </table>	Partition GOTO	User Code + [*] + Partition Number 0-2.	GOTO Home Partition	User Code + [*] + 0.	Panics	[*] + 1 or A Key (Zone 995). [*] + [#] or B Key (Zone 999). [#] + 3 or C Key (Zone 996).	View Downloaded Messages	Press 0 for 5 Seconds.	Display All Zone Descriptors	Press [*] for 5 Seconds.	Display User Self Help	Hold Any Key for 5 Seconds.
Partition GOTO	User Code + [*] + Partition Number 0-2.												
GOTO Home Partition	User Code + [*] + 0.												
Panics	[*] + 1 or A Key (Zone 995). [*] + [#] or B Key (Zone 999). [#] + 3 or C Key (Zone 996).												
View Downloaded Messages	Press 0 for 5 Seconds.												
Display All Zone Descriptors	Press [*] for 5 Seconds.												
Display User Self Help	Hold Any Key for 5 Seconds.												
Output Device Control Commands	<p>Activate Output Device as Programmed = User Code + [#] + 71. Activate Output Device as Programmed = User Code + [#] + 72. Activate Output Device Manually = User Code + [#] + 70. Activate Output Device or System Event Instantly = User Code + [#] + 77.</p>												
Test Mode Commands	<p>Burglary Walk-Test = User Code + 5. Fire Drill Test = User Code + [#] + 69 (Installer or Master Only). One-Man Fire Walk-Test = User Code + [#] + 68 (Installer Only)</p>												
Scheduling Commands	<p>Pre-Programmed Schedule Events = User Code + [#] + 80 (Installer or Master Only). Temporary Schedule Editing = User Code + [#] + 81 (Installer, Master, Manager Only). Extend Closing Window = User Code + [#] + 82 (Installer, Master, Manager Only). End User Output Device Programming = User Code + [#] + 83.</p>												
Relay Control Commands	<p>Activate Relay for Current Partition = User Code + 0.</p>												

Specifications

.....

Physical: 18"H X 14-1/2"W X 4.3"D

Electrical:

Primary Power: From ADEMCO No. 1451 Transformer with enclosure; rated 18VAC, 72VA.

Backup Battery: 12VDC, 12AH min to 34.4AH max lead acid battery (gel type).

Alarm Power: 12VDC, 1.7A max. for each Notification Appliance Circuit.

Aux. Standby Pwr 12VDC, 1A max.

Total Power Combined auxiliary standby and alarm currents must not exceed 2.3A.

Standby Time: 24 hours with 1A aux standby load using 34.4AH battery.

Fusing: Battery input, auxiliary and Notification Appliance Circuits are protected using PTC circuit protectors. All outputs are power limited.

Main Dialer

Line Seize: Double Pole

Ringer Equivalence: 0.7B

FCC Registration No.: AC3-USA-68192-AL-E

TLM Threshold Good line when tip-to-ring voltage greater than approximately 25V (13 when blue jumper cut) or when handset current greater than approximately 10mA. Bad line when both voltage and current below these levels.

Formats: ADEMCO High Speed, ADEMCO 4 + 2 Express, ADEMCO Low Speed, ADEMCO Contact ID, SESCOA and RADIONICS Low Speed

5140DLM BACKUP DIALER MODULE

Physical: 2.75"H X 4"W X 1"D

FCC Registration: AC3-USA-62628-MO-N

Contact ID Event Codes

TABLE OF CONTACT ID EVENT CODES

Code	Definition
110	Fire Alarm
111	Smoke Alarm
113	Waterflow Alarm
121	Duress
122	Silent Panic
123	Audible Panic
124	Duress Access Grant
125	Duress Egress Grant
131	Perimeter Burglary
132	Interior Burglary
133	24-Hour Burglary
134	Entry/Exit Burglary
135	Day/Night Burglary
140	ACS Zone Alarm
142	Polling Loop Short Alarm
150	24-Hour Auxiliary
200	Fire Supervisory
301	AC Loss
302	Low System Battery
305	System Reset
306	Program Tamper
308	System Shutdown
309	Battery Test Fail
310	Ground Fault
313	System Engineer Reset
320	ACS Relay Supervision
321	Bell 1 Trouble
322	Bell 2 Trouble
332	Poll Loop Short-Trouble
333	Expansion Module Failure
338	ACS Module Low Battery
339	ACS Module Reset
342	ACS Module AC Loss
343	ACS Module Self-Test Fail
344	RF Jam
351	Main Dialer Trouble
352	Backup Dialer Trouble
354	Communication Fail
373	Fire Loop Trouble
374	Exit Error by Zone
380	Trouble (global)
381	Loss of Supervision (RF)
382	Loss of V-PLEX Supervision
383	V-PLEX Sensor Tamper
384	RF Transmitter Low Battery
385	High Sensitivity Maintenance Signal
386	Low Sensitivity Maintenance Signal
389	Detector Self-Test Failed
401	O/C by User
403	Power-Up Armed/Auto-Arm

Code	Definition
406	Cancel by User
407	Remote Arm/Disarm (Download)
408	Quick Arm
409	Keyswitch O/C
411	Callback Requested
421	Access Denied
422	Access Granted
423	Door Force Open
424	Egress Denied
425	Egress Granted
426	Door Prop Open
427	Access Point DSM Trouble
428	Access Point RTE Trouble
429	ACS Program Entry
430	ACS Program Exit
431	ACS Threat Change
432	Access Point Relay/Trigger Fail
433	Access Point RTE Shunt
434	Access Point DSM Shunt/Unshunt
441	Armed STAY
451	Early Open/Close
452	Late Open/Close
453	Fail to Open
454	Fail to Close
455	Auto-Arm Fail
457	Exit Error by User
459	Recent Close
501	ACS Reader Disable
520	ACS Relay Disable
521	Bell 1 Bypass
522	Bell 2 Bypass
524	Auxiliary Relay Bypass
551	Main/Backup Dialer Bypass
570	Bypass
576	ACS Zone Shunt
577	ACS Point Bypass
602	Communicator Test
604	Fire Test
606	Listen-In to Follow
607	Burglary Walk-Test
608	Off-Normal
611	Fire Walk-Test – Point Tested
612	Fire Walk-Test – Point Not Tested
621	Event Log Reset
622	Event Log 50% Full
623	Event Log 90% Full
625	Time/Date Reset
631	Exception Schedule Change
632	Access Schedule Change
912	Fire Alarm Silence

Index

#93 Menu Mode Programming	4-2	Auto Disarming.....	6-1
#93 Menu Mode Programming Commands	4-4	Auto Trouble Restore.....	5-6
12/24 Hour Type Stamp Format.....	5-11	Auto-Arm Delay	5-12, 6-1
1451 Transformer	C-1	Auto-Arm Warning	6-1
24-hour Audible Alarm Type 07.....	4-6	Auto-Arm Warning Period	5-12
24-hour Auxiliary Alarm Type 08.....	4-6	Auto-Disarm Delay	5-12
24-hour Silent Alarm Type 06	4-6	AUTO-TEST DET?	10-2
24-Hour Trouble.....	4-7	Aux. Standby Pwr.....	C-1
2-Wire Latching Glassbreak Detectors.....	3-15	Auxiliary Input Alternate Function Enable	5-14
2-Wire Smoke Detectors	3-13	Auxiliary Power 1 Current Load.....	3-28
4100SM Serial Module.....	7-3	Auxiliary Power 2 Current Load.....	3-29
4101SN Relay Modules	3-23	Auxiliary Relay Connections.....	3-10
4204 and 4204CF Relay Modules	3-21	Auxiliary Relay Function Selection.....	5-15
4297 Polling Loop Extender	3-18	Backup Battery.....	C-1
4-Wire Smoke Detector Reset	3-11	Backup Dialer TouchTone or Rotary	5-15
4-Wire Smoke Detectors	3-14	Battery Capacity Calculation Worksheet	3-31
5140DLM Backup Dialer.....	3-12, C-1	Battery Saver	3-11
5800 Series Transmitters	3-21	Battery Selection Table.....	3-31
5881ENHC	3-19	Battery Test	10-1, 11-5
5881ENHC with Tamper Protection	3-19	Bell 1 Output Current Load	3-29
AC 60Hz or 50Hz.....	5-11	Bell 1 Timeout.....	5-2
AC LOSS	10-4	Bell 2 & Auxiliary Relay Timeout.....	5-15
AC Loss Keypad Sounding	5-2	Bell 2 Output Current Load	3-30
Access Group.....	9-3	Bell Output Supervision	3-7
Access Control Commands.....	6-9, B-1	Burglary Alarm Communicator Delay.....	5-7
Access Control Dialer Enables	5-10	Burglary Features on Partition 1 Enable	5-15
ACCESS GRP PGM	4-3	Burglary Trigger for Response Type 8	5-2
ACCESS POINT PGM	4-3	Burglary Walk Test.....	10-2
Access Point Type 27.....	4-7	Button RF.....	3-21
Access Schedules.....	6-5	Button RF (BR) Type 05.....	4-7
Action Code	6-9	Bypass Commands.....	6-9
Action Specifier.....	6-9	C.S. TRANSMIT?.....	10-2
Activation Time.....	6-9	Cabinet Lock.....	3-1, 3-3
Adding a User Code	9-3	Call Waiting Defeat.....	5-10
Adding an RF Key to a User Code	9-4	Callback	7-2
Addressing the Keypads	3-5	Callback Requested	7-1
ADEMCO 4+2 Express	3-12	CANADIAN EMISSIONS STATEMENTS	A-4
ADEMCO 4+2 Express	C-1	Cancel Verify	5-7
ADEMCO 4146	3-23	Changing a User Code.....	9-4
ADEMCO Contact ID.....	C-1	Check Messages	10-4
ADEMCO High Speed.....	C-1	Check or TRBL Display.....	5-13
ADEMCO Low Speed.....	3-12, C-1	Checksum Verification.....	5-5
Affects Lobby	2-2, 5-8	Chime on Bell 1	5-10
Agency Statements	A-1	CO Detector Alarm Type 14.....	4-6
Alarm Activation	3-10	Code + TEST [5].....	10-1, 10-2
Alarm Indicating Devices.....	3-7, 3-8	COMM FAILURE	10-4
Alarm Power	C-1	Common Lobby.....	2-2
Allow Disarm Outside Window if Alarm Occurs	5-12	Communication Defaults	4-5
Allow Disarming Only During Arm/Disarm Windows	5-12	Communications reporting options.....	3-25
ALPHA PROG	4-3	Communications to ECP	3-24
Antenna Fault	3-26	Communicator Central Station #1 Category Enable	5-5
Arm/Disarm Commands.....	6-9	Communicator Central Station #2 Category Enable	5-5
Arm-Away Type 21	4-7	Communicator Split Reporting	5-9
Armed Burglary System Test	10-3	Compass Downloading Software.....	7-3
Arms Lobby	2-2, 5-8	COMPASS downloading software	7-1
Arm-STAY Type 20.....	4-7	Compatible Alarm Indicating Devices	3-7
ATLIS-FAX FAXBACK	10-5	Confirmation of Arming Ding	5-2
Auto Arming.....	6-1	Confirmation of Arming Ding Bell 2 & Auxiliary Relay	5-15

Console Input (CS) Type 09.....	4-7	Event Log Programming.....	4-8
Contact ID	1-2	Event Log Types.....	5-11
CONTACT ID EVENT CODES.....	D-1	Event Logging Commands.....	B-1
Contacting Technical Support	10-5	EVENT/ACTION PGM	4-3
Control Panel as Stand-Alone Access Control.....	4-8	Exception Reports.....	6-2
Control Relay	5-11	Exit Delay #1	5-1
Conventions Used in This Manual	vii, ix	Exit Delay #2	5-1
Cross Zoning Pair Four.....	5-9	Exit Delay Reset	5-8
Cross Zoning Pair One.....	5-9	Exit Delay Sounding.....	5-10
Cross Zoning Pair Three.....	5-9	Exit Error	1-1
Cross Zoning Pair Two	5-9	Exit Error Logic Enable.....	5-8
Cross-Zoning	5-8	Exiting the User Edit Mode.....	9-4
Current Load Total	3-30	EXPERT MODE	4-3
CUSTOM INDEX.....	4-3	Extend Closing Window	6-1
Data Encryption.....	7-1	Extended Delay for Zone Types 17 & 18	5-14
Data Field Descriptions.....	5-1	FCC PART 68 NOTICE.....	A-3
Data Field Programming Mode.....	4-1	FCC REGISTRATION NO	C-1
Daylight Saving Time Start/End Month.....	5-11	Fire (Without Verification) Type 09	4-6
Daylight Saving Time Start/End Weekend.....	5-12	Fire Display Lock.....	5-13
Deleting a User Code	9-4	Fire Drill Test	10-1
DEVICE PROG	4-3	Fire Supervisory Response to Open/Short.....	5-13
Dial Tone Detection	5-4	Fire Supervisory Type 18.....	4-7
Dial Tone Pause.....	5-4	Fire Walk-Test Mode	1-2
Dialer Selection	5-14	Fire Waterflow Type 17	4-7
Dialer Test.....	10-1	Fire With Verification Type 16	4-6
DIP Switch Loop (DP) Type 07	4-7	First Communication	7-2
Dip Switch Polling Loop Right Loop (PS) Type 08 ...	4-7	First Test Report Time	5-7
Direct-Wire Downloading.....	7-3	Force Arm	6-1
Disable Download Callback.....	5-10	Force Arm Enable for Auto-Arm	5-12
Disarm Delay.....	6-1	Frwd. Power Loss.....	3-26
Disarm Type 22.....	4-7	Fusing	C-1
Display Burglary & Panic Alarms for Other Partitions	5-13	General Description	1-1
13		General Purpose (GP) Type 13.....	4-7
Display Fire Alarms of Other Partitions.....	5-13	Getting On-Line with a Control Panel.....	7-2
Display Troubles of Other Partitions	5-13	Global Arm ?.....	9-3
Door Status Monitor (DSM) Type 11	4-7	Global Arming	2-3
Download Command Enables	5-4	Go/No Go Test Mode.....	10-3
Download ID Number	5-3	Hardwire and Optional Expansion Zones	1-1
Download Phone Number.....	5-3	Hardwired (HW) Type 01	4-7
Downloading.....	7-1	Holiday Schedule	6-3
Downloading Access Security	7-1	Holiday Schedule Programming	6-8
Downloading Requirements	7-1	Holiday schedules.....	6-5
Dual Reporting.....	5-5	Holiday Schedules	6-7
Duress Codes Level 6	9-2	HSENS.....	10-4
Duress Reporting	9-2	Ignore Expansion Zone Tamper.....	5-2
Dynamic Signaling Delay.....	3-25, 5-5	Installer (User 1) Code Level 0	9-1
Dynamic Signaling Priority.....	3-25, 5-5	Installer Code	5-1
Early Power Detect.....	3-26	Installing The Control	3-1
Earth Ground	3-27	Installing the Control's Circuit Board	3-2, 3-4
Enable 5800 RF Button Force Arm	5-11	Installing V-Plex Devices	3-16
Enable 5800 RF Button Global Arm	5-11	Intelligent Test Report	5-2
Enable Bell 2 & Auxiliary Relay Chime Annunciation	5-15	Interior w/Delay Type 10	4-6
15		Interior, Follower Type 04.....	4-6
Enable Dialer Reports for Panics & Duress	5-7	Keypad Like Sounder.....	3-24
Enable GOTO for this Partition	5-12	Keypad Panic Enables	5-2
Enable J2 Triggers for Partition	5-12	Keypad Wiring	3-5
Enable Open/Close Report for Installer Code.....	5-4	Keypads	2-1
Enable Open/Close Report for Keyswitch.....	5-4	Keypads Addressing.....	3-6
Entering Programming Mode	4-1	Keyswitch	3-23
Entry Delay #1.....	5-1	Keyswitch Assignment.....	5-2
Entry Delay #2.....	5-1	Keyswitch LED Indications	3-23
Entry Warning.....	5-7	Keyswitch Tamper.....	3-23
Entry/Exit #1 Type 01	4-6	Limitation of Access	6-2
Entry/Exit #2 Type 02	4-6	Limitation of Access Schedules	6-11
Event Log.....	3-26	Limitation Of Access Schedules Programming	6-11
Event Log Printer On-Line Mode.....	5-11	Line Security.....	A-2

LINE SEIZE.....	C-1	Prevent Zone XXX Bypass.....	5-4
List of Figures.....	vi	Primary Format.....	5-4
LO BAT.....	10-4	Primary Phone Number.....	5-3
Lobby Partition.....	5-7	Primary Subscriber's Account Number.....	5-3
Log First Maintenance Signal.....	5-11	Printer Baud Rate.....	5-11
LOG RESULTS?.....	10-2	Program Modes.....	4-1
Long Range Radio ECP Programming.....	4-8	Programming Commands.....	B-1
Low Speed Format (Primary).....	5-4	PROGRAMMING COMMANDS.....	4-1
Low Speed Format (Secondary).....	5-5	Programming Entry Errors.....	4-1
LRR Battery.....	3-26	Programming Overview.....	4-1
LRR CRC is bad.....	3-26	Quick Arm.....	5-3, 9-1
LRR Trouble Messages.....	3-26	Quick Exit.....	ix
LSENS.....	10-4	Randomize AC Loss Report.....	5-2
Main Logic Board Supervision Type 28.....	4-7	RCVR SETUP ERROR.....	10-4
Manager Codes Level 2.....	9-1	Real-Time Clock.....	8-1
Master Codes Level 1.....	9-1	Recent Close.....	1-1
Master Keypad.....	2-4	Regulatory Agency Statements.....	A-1
Maximum Number of Dialer Attempts.....	5-14	Relay commands.....	6-9
Mercantile Premises Listing.....	3-3	Relay Timeout XXX Minutes.....	5-11
Mercantile Safe and Vault Listing.....	3-1, 3-4	Relay Timeout YYY Seconds.....	5-11
MODEM COMM.....	7-1, 10-4	Remote P/S Type 13.....	4-6
modems.....	7-1	REPORT CODE PROG.....	4-3
Momentary Exit Type 29.....	4-7	Reporting Formats.....	3-12
Mounting The Control Cabinet.....	3-1, 3-3	Request to Exit (RTE) Type 12.....	4-7
Multi-Access ?.....	9-3	Reset on Second OFF for Bell 1.....	5-15
Multiple Alarms.....	5-2	Reset on Second OFF for Bell 2.....	5-15
Multiple Partition Access.....	9-2	Restore Report Timing.....	5-7
MX8000 Receiver.....	3-12	Restrict Disarming.....	6-1
No Alarm Response Type 23.....	4-7	RF Receiver Supervision Check-in Interval.....	5-9
Normally Closed or EOLR (Zones 2-8).....	5-4	RF System Advisories.....	3-19
Notification Appliance Circuit Supervision.....	3-7	RF System Operation and Supervision.....	3-19
Number of Partitions.....	5-11	RF Transmitter Check-in Interval.....	5-9
OC or OPEN CIRCUIT.....	3-6	RF Transmitter Low Battery Reporting.....	5-9
Off-Normal Report.....	10-4	RF Transmitter Low Battery Sound.....	5-9
On-Line Control Functions.....	7-2	Ring Count.....	7-2
Open/Close Reporting.....	9-2	Ring Detection Count.....	5-4
Open/Close Reports by Exception.....	5-12, 6-3	RINGER EQUIVALENCE.....	C-1
Open/Close Schedule.....	6-3	RJ31X.....	3-11
Open/Close Schedule Programming.....	6-7	RLY VOICE DESCR.....	4-3
Open/Close Schedules.....	6-5, 6-6	Scheduling.....	6-1
Open/Close Windows.....	6-9	Scheduling Commands.....	B-1
Operator Access Levels.....	7-1	Scheduling Menu Mode.....	6-4
Operator Codes Levels 3-5.....	9-1	Scheduling Programming Menu Structure.....	6-5
Output Device Control Commands.....	B-1	Scheduling Programming Options.....	6-5
Output Devices.....	3-21	Secondary Format.....	5-4
OUTPUT PGM.....	4-3	Secondary Phone Number.....	5-3
Overvoltage Protection.....	3-12	Secondary Subscriber Account Number.....	5-7
PABX Access Code.....	5-3	Send Cancel If Alarm + Off.....	5-10
Panic Button or Speedkey.....	5-9	Serial Number Devices.....	3-17
Partitioned System.....	2-1	Serial Number Polling Loop (SL) Type 06.....	4-7
Partitioning.....	1-1, 2-1	Sescoa/Radionics.....	3-12
Partition-Specific Data Fields.....	4-2	Sescoa/Radionics Select.....	5-5
PassPoint Access Control (ACS) Type 10.....	4-7	Setting the Date.....	8-1
Perimeter Type 03.....	4-6	Setting the Time.....	8-1
Peripherals Devices.....	1-1	Specifications.....	C-1
Permanent Keypad Display Backlighting.....	5-10	Standard/Expanded Reporting Primary.....	5-5
Phone Module Access Code.....	5-2	Standard/Expanded Reporting Secondary.....	5-5
PLL out of Lock.....	3-26	Standby Battery Size.....	3-31
polling loop.....	3-16	Supervised RF.....	3-21
Polling Loop Current Draw.....	3-28	Supervised RF (RF) Type 03.....	4-7
Polling Loop Devices.....	3-16	Supervision Pulses for LRR.....	5-13
Polling Loop Supervision.....	3-17	Supervisory Messages.....	10-4
Power Failure.....	10-4	Suppress Transmitter Supervision Sound.....	5-10
Power Supply Load.....	3-27	Swinger Suppression.....	5-7
Power Unattained.....	3-26	System Commands.....	B-1
Power-Up in Previous State.....	5-3	System Communication.....	1-2

SYSTEM LO BAT	10-4
System LoBat”	10-1
System Messages	10-4
System Zone Bypass Inhibit.....	5-15
System-Wide Data Fields.....	4-2
Telco Handoff	7-3
Telephone Line Connections	3-11
Telephone Line Supervision.....	3-12
TELEPHONE OPERATIONAL PROBLEMS	A-3
Temporal Siren Pulse.....	5-1
Temporary Schedule.....	6-3
Temporary Schedules.....	6-12
Temporary Schedules Programming.....	6-13
Test Mode Commands	B-1
Test Report Interval.....	5-3
Testing The System	10-1, 11-5
Time Driven Events	6-2
Time Driven Events Worksheet.....	6-8
Time Window Definitions.....	6-2
Time Windows	6-5, 6-6
Time Windows Programming	6-6
Timed Events	6-5
Time-Driven Event Programming.....	6-10
Time-Driven Events	6-8
TouchTone or Rotary Dial.....	5-3
TouchTone with Rotary Backup.....	5-9
Transformer Connections.....	3-26
Transmitter Battery Life.....	3-21
Transmitter ID Sniffer Mode	10-3
Transmitter Input Types.....	3-21
Transmitter Supervision	3-21
Trigger Outputs Function Selection	5-14
Trouble by Day/Alarm by Night Type 05.....	4-6
Trouble Conditions.....	10-4
Trouble Messages	10-4
Trouble/Supervisory Activation	3-11
Turning the System Over to the User	10-5
UL Installation Requirements.....	A-1
UL1610 Central Station Burglary Alarm	A-2
UL365 Police Station Connected Burglar Alarm.....	A-2
UL609 Local Mercantile Premises/Local Mercantile Safe & Vault	A-2

UL864/NFPA Central Station and Remote Station Fire	A-1
UL864/NFPA Local Fire.....	A-1
UNABLE TO ARM LOBBY PARTITION	2-2
Unsupervised RF.....	3-21
Unsupervised RF (UR) Type 04.....	4-7
USE BELL DING?	10-1
Use Partition Descriptor	5-12
User Access Codes.....	9-1
User Code Authority Levels	9-1
User Code Commands.....	B-1
User Code Rules.....	9-2
User Scheduling Menu Mode	6-13
Users	2-1
View Capabilities	9-1
VIP Module Phone Code.....	5-2
Waterflow Alarm Silence Option.....	5-14
Wire Run Length/Gauge	3-5
Wireless Keypad Assignment	5-10
Wireless Keypad Tamper Detect.....	5-10
Wireless System Commands	B-1
Wireless Zone Expansion.....	3-19
Wiring Devices to Zones 1-8	3-13
Without Line Security	A-2
Worksheets to calculate the total current.....	3-27
World Wide Web Address.....	10-5
Yuasa.....	3-31
Zone 5 Audio Alarm Verification	5-11
Zone 6 Alternate Function Enable	5-14
Zone 6 Tamper Configuration	3-15
Zone Defaults	4-4
Zone Index	4-4
Zone Input Type Definitions	4-7
Zone Number Designations.....	4-4
ZONE PROG.....	vii, 4-3
Zone Response Type Definitions.....	4-5
Zone Type 18 Delay Use	5-13
Zone Type Restores for Zone Types 1-8	5-6
Zone Type Restores for Zone Types 9 10 & 14.....	5-7
Zone Types 17 & 18 Delay	5-14
Zones.....	2-1

WARNING!

THE LIMITATIONS OF THIS ALARM SYSTEM

While this System is an advanced wireless security system, it does not offer guaranteed protection against burglary, fire or other emergency. Any alarm system, whether commercial or residential, is subject to compromise or failure to warn for a variety of reasons. For example:

- Intruders may gain access through unprotected openings or have the technical sophistication to bypass an alarm sensor or disconnect an alarm warning device.
- Intrusion detectors (e.g., passive infrared detectors), smoke detectors, and many other sensing devices will not work without power. Battery-operated devices will not work without batteries, with dead batteries, or if the batteries are not put in properly. Devices powered solely by AC will not work if their AC power supply is cut off for any reason, however briefly.
- Signals sent by wireless transmitters may be blocked or reflected by metal before they reach the alarm receiver. Even if the signal path has been recently checked during a weekly test, blockage can occur if a metal object is moved into the path.
- A user may not be able to reach a panic or emergency button quickly enough.
- While smoke detectors have played a key role in reducing residential fire deaths in the United States, they may not activate or provide early warning for a variety of reasons in as many as 35% of all fires, according to data published by the Federal Emergency Management Agency. Some of the reasons smoke detectors used in conjunction with this System may not work are as follows. Smoke detectors may have been improperly installed and positioned. Smoke detectors may not sense fires that start where smoke cannot reach the detectors, such as in chimneys, in walls, or roofs, or on the other side of closed doors. Smoke detectors also may not sense a fire on another level of a residence or building. A second floor detector, for example, may not sense a first floor or basement fire. Finally, smoke detectors have sensing limitations. No smoke detector can sense every kind of fire every time. In general, detectors may not always warn about fires caused by carelessness and safety hazards like smoking in bed, violent explosions, escaping gas, improper storage of flammable materials, overloaded electrical circuits, children playing with matches, or arson. Depending on the nature of the fire and/or location of the smoke detectors, the detector, even if it operates as anticipated, may not provide sufficient warning to allow all occupants to escape in time to prevent injury or death.
- Passive Infrared Motion Detectors can only detect intrusion within the designed ranges as diagrammed in their installation manual. Passive Infrared Detectors do not provide volumetric area protection. They do create multiple beams of protection, and intrusion can only be detected in unobstructed areas covered by those beams. They cannot detect motion or intrusion that takes place behind walls, ceilings, floors, closed doors, glass partitions, glass doors, or windows. Mechanical tampering, masking, painting or spraying of any material on the mirrors, windows or any part of the optical system can reduce their detection ability. Passive Infrared Detectors sense changes in temperature; however, as the ambient temperature of the protected area approaches the temperature range of 90° to 105°F (32° to 40°C), the detection performance can decrease.
- Alarm warning devices such as sirens, bells or horns may not alert people or wake up sleepers if they are located on the other side of closed or partly open doors. If warning devices are located on a different level of the residence from the bedrooms, then they are less likely to waken or alert people inside the bedrooms. Even persons who are awake may not hear the warning if the alarm is muffled by noise from a stereo, radio, air conditioner or other appliance, or by passing traffic. Finally, alarm warning devices, however loud, may not warn hearing-impaired people.
- Telephone lines needed to transmit alarm signals from a premises to a central monitoring station may be out of service or temporarily out of service. Telephone lines are also subject to compromise by sophisticated intruders.
- Even if the system responds to the emergency as intended, however, occupants may have insufficient time to protect themselves from the emergency situation. In the case of a monitored alarm system, authorities may not respond appropriately.
- This equipment, like other electrical devices, is subject to component failure. Even though this equipment is designed to last as long as 20 years, the electronic components could fail at any time.

The most common cause of an alarm system not functioning when an intrusion or fire occurs is inadequate maintenance. This alarm system should be tested weekly to make sure all sensors and transmitters are working properly. The security keypad (and remote keypad) should be tested as well.

Wireless transmitters (used in some systems) are designed to provide long battery life under normal operating conditions. Longevity of batteries may be as much as 4 to 7 years, depending on the environment, usage, and the specific wireless device being used. External factors such as humidity, high or low temperatures, as well as large swings in temperature, may all reduce the actual battery life in a given installation. This wireless system, however, can identify a true low battery situation, thus allowing time to arrange a change of battery to maintain protection for that given point within the system.

Installing an alarm system may make the owner eligible for a lower insurance rate, but an alarm system is not a substitute for insurance. Homeowners, property owners and renters should continue to act prudently in protecting themselves and continue to insure their lives and property. We continue to develop new and improved protection devices. Users of alarm systems owe it to themselves and their loved ones to learn about these developments.

For the latest warranty information, please go to:
www.honeywell.com/security/hsc/resources/wa

Honeywell

2 Corporate Center Drive, Suite 100

P.O. Box 9040, Melville, NY 11747

Copyright © 2009 Honeywell International Inc.

www.honeywell.com/security



K3521V4 10/09 Rev A